

VRV™ System R-407C PLUS Series

Part 1 General Information 1

1. Product Outline	2
1.1 Year 2000 Models Using New Refrigerant	2
1.2 Outline of New Series Products	3
1.3 Model Configuration and Combination	5
2. Points to Bear in Mind at the System Design	6
2.1 Points Relating to the Performance of the Air Conditioning Units	6
2.2 The Installation is of Vital Importance	7
2.3 Striking a Balance between System Installation and General Construction Work (Comprehensive Flow Chart)	8
2.4 Points to Bear in Mind when Preparing the Contract Drawings	9
3. Installation	12
3.1 Step by Step Installation Procedure	12
3.2 Work Involved in Individual Operations and Points to be Borne in Mind	13
4. Test Operation	56
4.1 Procedure and Outline	56
4.2 Operation When Power is Turned On	58
4.3 Outdoor Unit PC Board Ass'y	59
4.4 Setting Modes	61
4.5 Cool / Heat Mode Selection	68
4.6 Low Noise Operation	73
4.7 Demand Control	74
4.8 Sequential Start	75
4.9 Wiring Check Operation	76
4.10 Additional Refrigerant Charge Operation	77
4.11 Refrigerant Recovery Mode	78
4.12 Indoor Field Setting	79
4.13 Centralized Control Group No. Setting	84
4.14 Contents of Control Modes	86
5. Caution for Refrigerant Leaks	88
5.1 Caution for Refrigerant Leaks	88
6. Hand Over to Customer	91
6.1 Operational Steps	91
7. Appendix	92
7.1 Operating Noise of Indoor Units	92
7.2 Allowable Piping Length	94
7.3 Selection of Refrigerant Pipe Size	95
7.4 Additional Charge of Refrigerant	97
7.5 REFNET Pipe Connections for VRV R-407C PLUS Series	100



Большая библиотека технической документации

<https://splitsystema48.ru/instrukcii-po-ekspluatácii-kondicionerov.html>

каталоги, инструкции, сервисные мануалы, схемы.

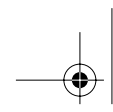

7.9 Bad Examples and Good Examples in Installation..... 115

Part 2 Installation Manual 123

1. Introduction 124

1.1 Introduction..... 124

1.2 Cautions in Installation 125

1.3 Combination 126

1.4 Standard Operation Limit..... 127

1.5 Standard Supplied Accessories..... 128

1.6 Optional Accessories..... 129

1.7 Technical Specifications 130

1.8 Electrical Specifications..... 131

2. Main Components 132

2.1 Main Components 132

3. Selection of Location 133

3.1 Selection of Location 133

4. Inspecting and Handling the Unit 134

4.1 Inspecting and Handling the Unit..... 134

5. Unpacking and Placing the Unit 135

5.1 Unpacking and Placing the Unit 135

6. Refrigerant Piping 136

6.1 Refrigerant Piping..... 136

6.2 Selection of Piping Material..... 137

6.3 Connecting the Refrigerant Piping..... 138

6.4 Leak Test and Vacuum Drying 143

6.5 Pipe Insulation 144

6.6 Additional Refrigerant Charge 145

7. Field Wiring 147

7.1 Field Wiring..... 147

7.2 Internal Wiring 148

7.3 Optional Parts Cool/Heat Selector..... 150

7.4 Power Circuit and Cable Requirements 151

7.5 General..... 152

7.6 Examples..... 153

8. Before Operation..... 158

8.1 Checks before Initial Start-Up..... 158

8.2 Test Run 159

9. Caution for Refrigerant Leaks 163

9.1 Caution for Refrigerant Leaks..... 163

10. Appendix of Installation 165

10.1 Example of Connection 165

Part 3 New Refrigerant R-407C 167

1. Precautions in Servicing the Models with New-type Refrigerant..... 168

1.1 Tools Required 168

1.2 Notes for Work Procedures 169

2. Changes Required by New Refrigerants..... 170

2.1 Changes Required by New Refrigerant..... 170

3. Refrigerant and Refrigerant Oil Characteristics 171



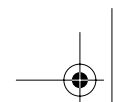

SiE33-003

- 3.1 Refrigerant Characteristics 171
- 3.2 Refrigerant Oil Characteristics..... 173
- 4. Refrigerant Cylinders 174
 - 4.1 Cylinder Specifications 174
 - 4.2 Handling of Cylinders 175
- 5. Service Tools 176
 - 5.1 Tool Compatibility 176
 - 5.2 New Tools Required for HFCs and Reasons of Change..... 177
- 6. Cautions During Service Operations
(Changes Required by New Refrigerants) 180
 - 6.1 The Three Basic Rules for Refrigerant Piping
Must Be More Strictly Observed..... 180
- 7. Operation Guideline 181
 - 7.1 Operation Guideline..... 181
- 8. Temperature-pressure Conversion Table for New Refrigerants 182
 - 8.1 Pressure and Temperature..... 182
- 9. Measures to Take in the Case of Gas Leaks 183
 - 9.1 Gas Shortage 183
 - 9.2 Measure for Gas Shortage 184
- 10. Safety Precautions 185
 - 10.1 Safety Precautions 185
- 11. Problems Resulting from Negligence of Caution Items..... 186
 - 11.1 Problems Resulting from Negligence of Caution Items 186
- 12. Difference Between Pascal and Conventional Pressure Unit 187
 - 12.1 Comparison of MPa and kgf/cm² 187
- 13. Thermodynamic Characteristic Charts (HFC407C) 188
 - 13.1 Thermodynamic Characteristics of R-407C..... 188

Index i

Drawings & Flow Charts iii

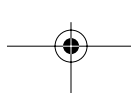

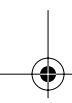
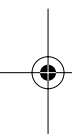
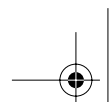

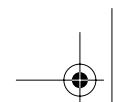

Part 1 General Information

1. Product Outline	2
1.1 Year 2000 Models Using New Refrigerant	2
1.2 Outline of New Series Products.....	3
1.3 Model Configuration and Combination	5
2. Points to Bear in Mind at the System Design.....	6
2.1 Points Relating to the Performance of the Air Conditioning Units	6
2.2 The Installation is of Vital Importance.....	7
2.3 Striking a Balance between System Installation and General Construction Work (Comprehensive Flow Chart)	8
2.4 Points to Bear in Mind when Preparing the Contract Drawings.....	9
3. Installation	12
3.1 Step by Step Installation Procedure	12
3.2 Work Involved in Individual Operations and Points to be Borne in Mind	13
4. Test Operation	56
4.1 Procedure and Outline.....	56
4.2 Operation When Power is Turned On	58
4.3 Outdoor Unit PC Board Ass'y	59
4.4 Setting Modes.....	61
4.5 Cool / Heat Mode Selection.....	68
4.6 Low Noise Operation	73
4.7 Demand Control	74
4.8 Sequential Start.....	75
4.9 Wiring Check Operation	76
4.10 Additional Refrigerant Charge Operation	77
4.11 Refrigerant Recovery Mode.....	78
4.12 Indoor Field Setting	79
4.13 Centralized Control Group No. Setting	84
4.14 Contents of Control Modes.....	86
5. Caution for Refrigerant Leaks	88
5.1 Caution for Refrigerant Leaks.....	88
6. Hand Over to Customer	91
6.1 Operational Steps.....	91
7. Appendix	92
7.1 Operating Noise of Indoor Units	92
7.2 Allowable Piping Length	94
7.3 Selection of Refrigerant Pipe Size.....	95
7.4 Additional Charge of Refrigerant	97
7.5 REFNET Pipe Connections for VRV R-407C PLUS Series	100
7.6 VRV Inspection Sheet	106
7.7 Piping System Diagrams	110
7.8 Wiring Diagram.....	113
7.9 Bad Examples and Good Examples in Installation.....	115

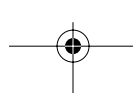

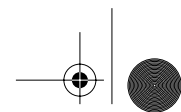

1. Product Outline

1.1 Year 2000 Models Using New Refrigerant

Outdoor Unit Series

● New model

Series name	Equivalent horsepower (HP)	16	18	20	24	26	28	30
R-407C VRV PLUS series		●	●	●	●	●	●	●

Indoor Unit Series

● New model ◎ Model change ○ Continued model

		Type P20	Type P25	Type P32	Type P40	Type P50	Type P63	Type P80	Type P100	Type P125	Type P200	Type P250
Ceiling mounted cassette type	Multi-flow type	—	—	◎	◎	◎	◎	◎	◎	◎	—	—
	Double-flow type	○	○	○	○	○	○	○	—	○	—	—
	Corner type	—	○	○	○	—	○	—	—	—	—	—
Ceiling mounted built-in type		○	○	○	○	○	○	○	○	○	—	—
Ceiling mounted duct type		—	—	—	○	○	○	○	○	○	○	○
Ceiling suspended type		—	—	○	—	—	○	—	○	—	—	—
Wall mounted type		●	○	○	○	○	○	—	—	—	—	—
Floor standing type		○	○	○	○	○	○	—	—	—	—	—
Concealed floor standing type		○	○	○	○	○	○	—	—	—	—	—

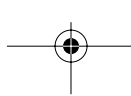

1.2 Outline of New Series Products

In addition to the use of a new refrigerant (R-407C), the new series products incorporate a function-unit-less structure for significantly improved flexibility and ease of installation.

System outline

Standard series

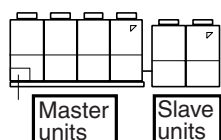

General name RSXYP~KJY1
 Master unit name RXPY~KJY1
 Slave unit name RXEP8-10KJY1

(V0800)

- No function unit
 All models combine master units and slave units or master units, slave units and Plus units.
- All models use a new refrigerant with low ozone destruction potential and global warming potential to minimize environmental loads (see Feature (1)).
 With a value of 1 given to the ozone destruction potential and global warming potential of the R11 refrigerant, smaller values mean less environmental impact.

Feature (1)

- Use of new refrigerant (R-407C) that does not deplete the ozone layer

Refrigerant		Condensing pressure (MPa)	Capacity *1	COP	Ozone destruction potential	Global warming potential
R22	Single-component	1.88	100	100	0.05	0.43
R-407C	Non-azeotropic	2.05	98	90~97	0	0.38

*1 Capacity value based on theoretical refrigerating cycle

- Reduction of refrigerant charge volume (approx. 75% as compared to R22-refrigerant unit with 20 HP and 5-m pipe)
 --- Mainly by elimination of function units, simplification of refrigerant circuits and reduction of internal volume.

< Global warming potential >

Water vapor and carbon gas allow solar rays to pass through, but they hinder the penetration of heat rays from the surface of the earth. Methane, chlorofluorocarbons and dinitrogen monoxide have similar characteristics. When the amounts of these gases in the atmosphere increase, heat that normally escapes through the atmosphere remains near the earth's surface, thus increasing the temperature of air. The degree of the effect to the earth caused by the atmospheric temperature rise due to these gases is numerically expressed by global warming potential (GWP).

Feature (2)

- Dramatically improved flexibility and ease of field installation by function-unit-less structure
 --- Simpler piping work at installation sites
 --- Reduced unit installation area

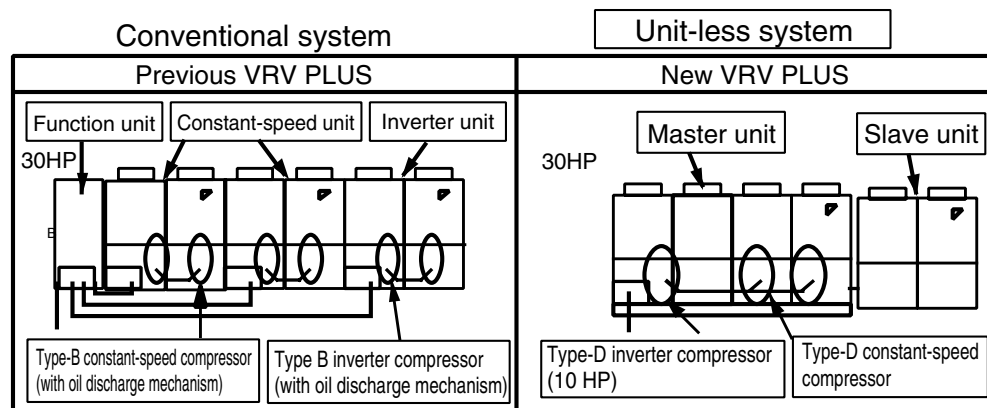

(V0802)

Feature (3)

- Reduction of installation area

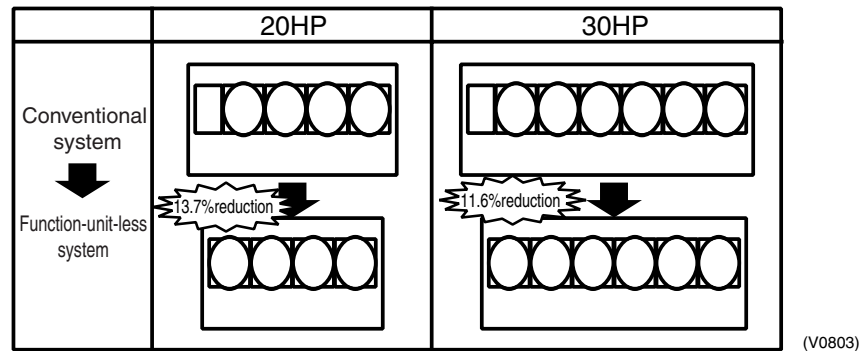

- Simpler piping work at installation sites

	20HP	30HP
Pipe connecting locations	14 joints → 6 joints	20 joints → 6 joints

Other versatile functions are provided

- Long refrigerant piping : equivalent length of 125, actual length of 100 m and height difference of 50 m.
- Connection of indoor unit of varying capacities and types totaling 130% (max.) of outdoor unit by capacity.

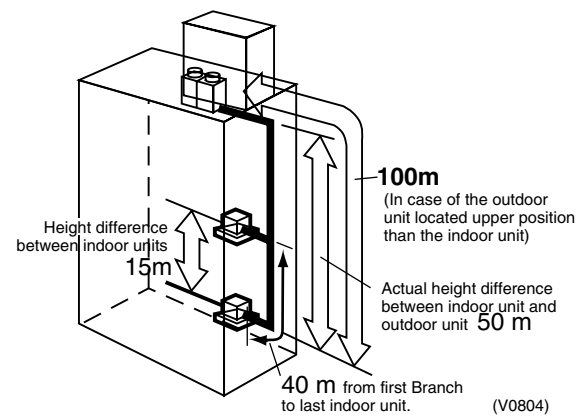

- Individual control of up to 20 indoor units with one 20HP class outdoor unit

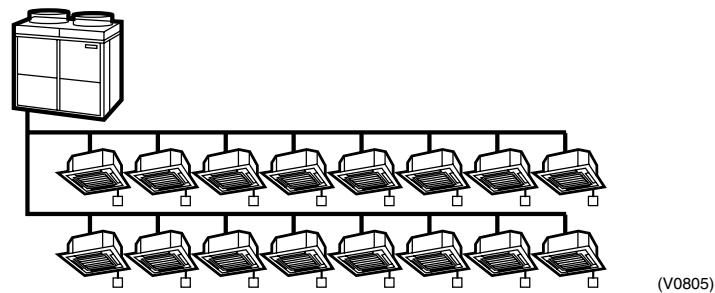

- For VRV PLUS

Outdoor unit name	No. of indoor units connectable
RSXYP16~20K	20 units
RSXYP24~30K	32 units

Others

- High efficiency with power factor of 90% or higher
- Cooling operation with outdoor air temperature as low as -5°C
- Heating operation with outdoor air temperature as low as -15°C
- Simple REFNET piping system
- Super wiring system
- Automatic address setting function
- Built-in wiring error check function
- Equipped with sequential start function
- Nighttime low-noise mode for reduced operating sound

1.3 Model Configuration and Combination

Number of units and capacity of connectable indoor units

Standard series	Equivalent output		16HP	18HP	20HP	24HP
	R-407C VRV PLUS series system model		RSXYP16KJ	RSXYP18KJ	RSXYP20KJ	RSXYP24KJ
	Outdoor unit combination	Main unit	RXYP8KJ	RXYP10KJ	RXYP10KJ	RXYP16KJ
		Sub unit	RXEP8KJ	RXEP8KJ	RXEP10KJ	RXEP8KJ
	Total number of connectable indoor units		Up to 20 units			Up to 32 units
Total capacity of connectable indoor units		200~520	225~585	250~650	300~780	
Standard series	Equivalent output		26HP	28HP	30HP	
	R-407C VRV PLUS series system model		RSXYP26KJ	RSXYP28KJ	RSXYP30KJ	
	Outdoor unit combination	Main unit	RXYP16KJ	RXYP20KJ	RXYP20KJ	
		Sub unit	RXEP10KJ	RXEP8KJ	RXEP10KJ	
	Total number of connectable indoor units		Up to 32 units			
Total capacity of connectable indoor units		325~845	350~910	375~975		

Connectable indoor unit

Indoor unit		Model name
Ceiling mounted cassette type	Multi-flow type	FXYFP32KVE-40KVE-50KVE-63KVE-80KVE-100KVE-125KVE
	Double flow type	FXYCP20KV1-25KV1-32KV1-40KV1-50KV1-63KV1-80KV1-125KV1
	Corner type	FXYKP25KV1-32KV1-40KV1-63KV1
Ceiling mounted built-in type		FXYSP20KV1-25KV1-32KV1-40KV1-50KV1-63KV1-80KV1-100KV1-125KV1
Ceiling mounted duct type		FXYMP40KV1-50KV1-63KV1-80KV1-100KV1-125KV1-200KV1-250KV1
Ceiling suspended type		FXYHP32KV1-63KV1-100KV1
Wall mounted type		FXYAP20KV1-25KV1-32KV1-40KV1-50KV1-63KV1
Floor standing type		FXYLP20KV1-25KV1-32KV1-40KV1-50KV1-63KV1
Concealed floor standing type		FXYLMP20KV1-25KV1-32KV1-40KV1-50KV1-63KV1

Indoor unit capacity

New refrigerant model code	P20 type	P25 type	P32 type	P40 type	P50 type	P63 type	P80 type	P100 type	P125 type	P200 type	P250 type
Selecting model capacity	2.2kW	2.8kW	3.5kW	4.5kW	5.6kW	7.0kW	9.0kW	11.2kW	14.0kW	22.4kW	28.0kW
Equivalent output	0.8HP	1HP	1.25HP	1.6HP	2.0HP	2.5HP	3.2HP	4HP	5HP	8HP	10HP

Use the above tables to determine the capacities of indoor units to be connected. Make sure the total capacity of indoor units connected to each outdoor unit is within the specified value (kW).

- The total capacity of connected indoor units must be within a range of 50 to 130% of the rated capacity of the outdoor unit.
- In some models, it is not possible to connect the maximum number of connectable indoor units. Select models so the total capacity of connected indoor units conforms to the specification.

Combination example

- RSXYP20KJ / 20-unit system

Indoor unit / FXYCP25K × 20 units

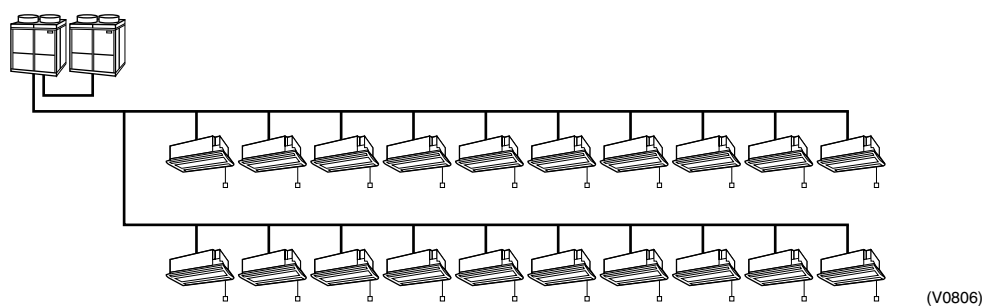

2. Points to Bear in Mind at the System Design

2.1 Points Relating to the Performance of the Air Conditioning Units

A number of points need to be borne in mind at the system design stage in order to ensure the mechanical efficiency of the air conditioning units.

1. Path of refrigerant piping between outdoor and indoor units, height difference and pipe length.

- Path of refrigerant piping should be determined such that length of piping is kept to a minimum.
- Piping should be kept within permissible limits in terms of length and height difference.

2. Positioning of outdoor unit

- Position such that maintenance and repairs can be carried out. (leave room for servicing)
- Avoid reduction of airflow and short circuiting

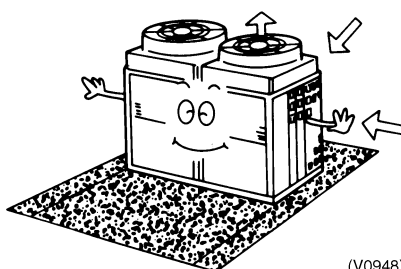

(V0948)

- Avoid reduction of airflow and short circuiting

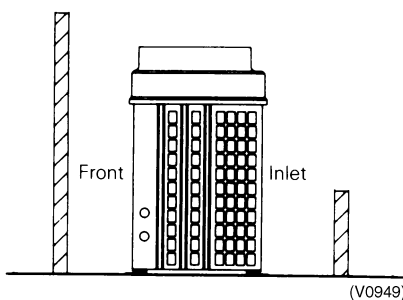

(V0949)

3. Positioning of indoor unit

- Position such that maintenance and repairs can be carried out. (inspection port positions and size check)
- Avoid short circuiting
- Ensure sufficient drain pipe gradient (need for drain-up kit etc.)
- In the case of a ceiling mounted type make sure ceiling depth is sufficient (need for high performance filter, etc.)

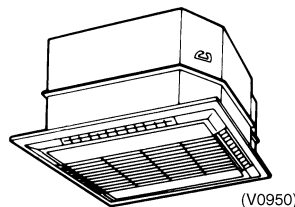

(V0950)

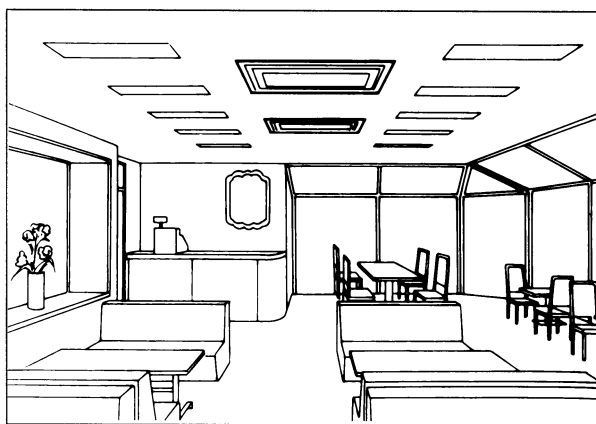

(V0951)

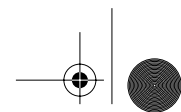

2.2 The Installation is of Vital Importance

The analysis of major installation problems experienced during the year of 1988 is shown below;

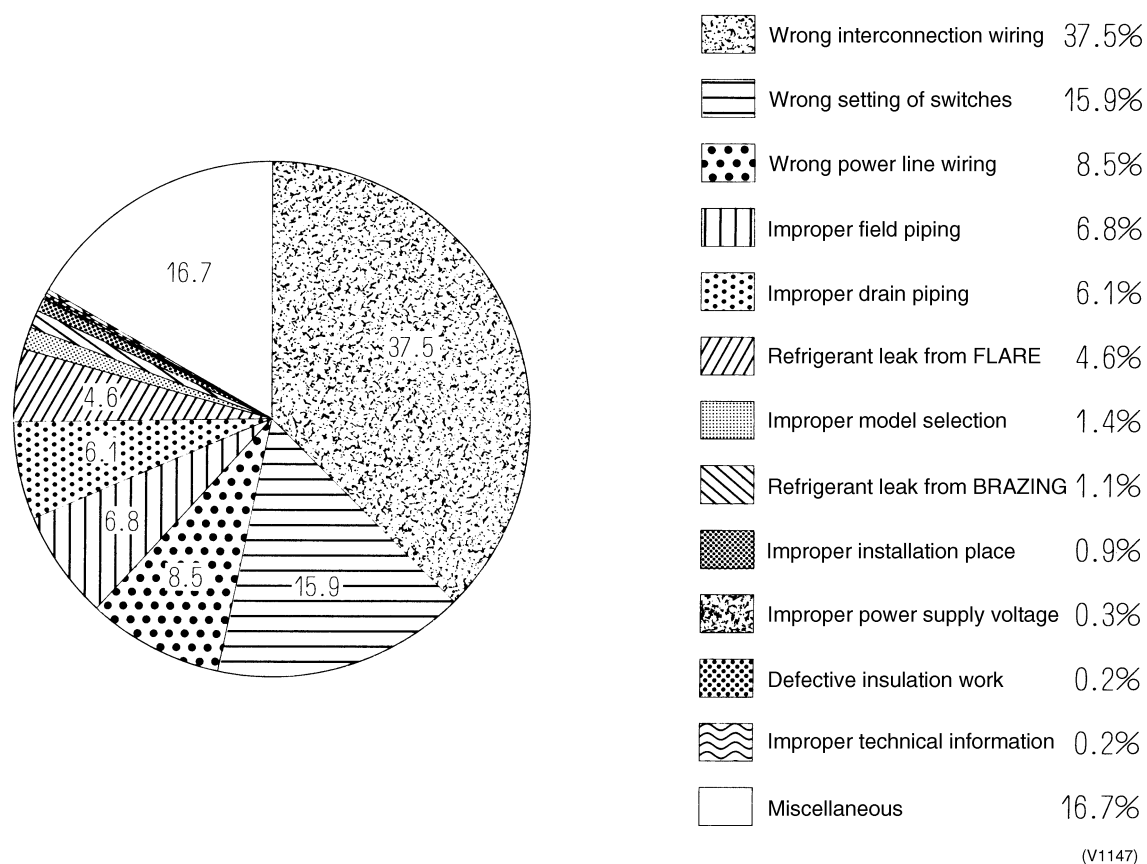

How these installation problems affect an equipment are shown below:

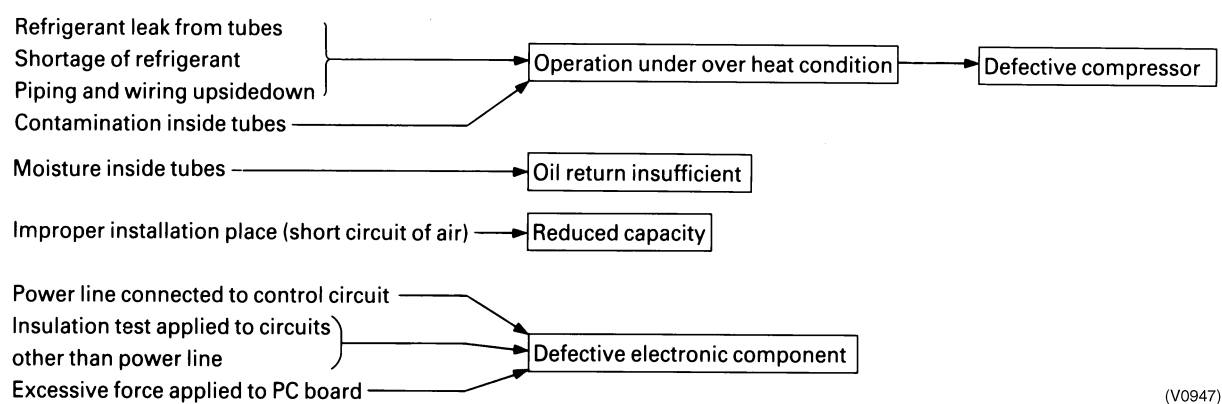

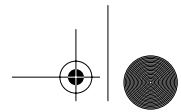

2.3 Striking a Balance between System Installation and General Construction Work (Comprehensive Flow Chart)

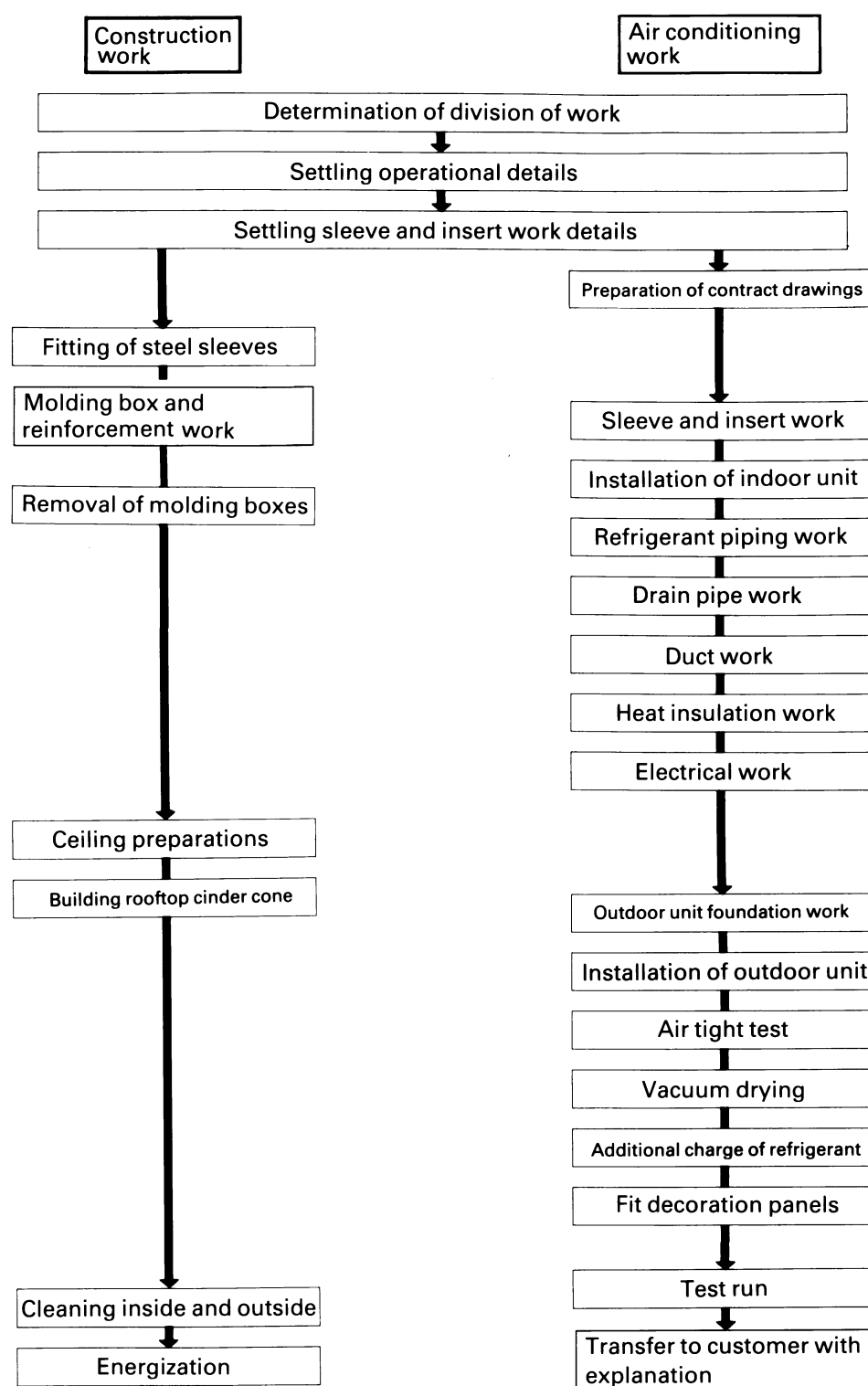

(V0952)



- Note:**
1. The division of the work should be thoroughly clarified. (This applies particularly to work relating to the connection of control wiring, fitting of remote control and central control panel, boundary work on areas such as connection of drain piping and humidification supply piping, inspection and foundation)
 2. Keep a constant check on the progress of the construction work to avoid deviations from the air conditioning work schedule.
 3. For sleeve and insert work the positions of ceiling girders should be confirmed and sleeve and insert requirement, hole diameters, positioning and numbers decided. This is particularly important in the case of sleeves for drain piping.



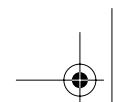

2.4 Points to Bear in Mind when Preparing the Contract Drawings

The following points should be borne in mind when preparing the contract drawings from the original drawings and the execution drawings.

The contract drawings for the air conditioning system are blueprints for the performance of the necessary work which are drawn up on the basis of the original drawings in such a way that a working balance is achieved between the specific requirements of each individual aspect of the work.

Contract Drawing

Objectives include:

- The drawings should be easily comprehensible to those carrying out the work.
- The contents of the drawings should not be subject to subsequent alteration.

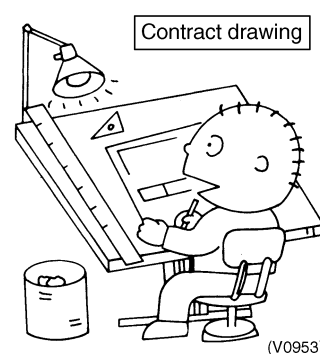

(V0953)

The following is a list of the main points to be considered when preparing contract drawings for the **VRV** System and should be used as a reference during this stage of the work:

2.4.1 At the Contract Drawing Stage the Following Points are Critical!!

	Check points	
Arrangement of units	<ol style="list-style-type: none"> 1. Have you left the access passages clear and allowed sufficient room for servicing? 2. Have you taken full account of the possibility of short circuits? (Both indoor and outdoor units) 3. Can the air filters be replaced easily? 4. Have you indicated the size and location of the ceiling inspection ports? (Make sure there no other installations in the area above) 5. Have you taken into account the depth of the installation area? (In case of ceiling built-in type) 6. Have you specified the position of the indoor unit clearly? (Have you taken full account of relevant features of the local ventilation, humidity and lighting?) 	
Refrigerant piping	<ol style="list-style-type: none"> 1. Is the piping system correctly connected? 2. Are the rise and fall pipes correctly connected? 3. Are the lengths and height differences of the pipes within the recommended limits? 	<p>(Example of a contract drawing)</p>
Operational control	<ol style="list-style-type: none"> 1. Are the interconnections between the piping and wiring of the indoor and outdoor units clearly shown? 2. Are the numbers of the local setting switches clearly shown? (Group No. and Unit No.) 3. Are the wiring connections between the remote control and the centralized and remote controls clearly shown? Refer to the notes relating to the preparation of the control wiring system diagrams (see next page) 4. Are the different types of wires clearly marked? 5. Are there any problems with the way the power supply cables and control wiring have been separated or bound together? 6. Are the inter-floor connections of the control wiring correct? 7. Is the position of the remote control clearly marked? 	
Miscellaneous	<ol style="list-style-type: none"> 1. Have you checked the gradient of the drain piping? (Must be at least 1/100) 	

2.4.2 Main Considerations in Preparation of Control Circuit Diagrams

In addition to the design of the appropriate this system configuration it is also essential that the control system be made amply clear. If the system is designed and installed without a clear, comprehensive plan then problems are inevitably going to occur during the test run.

Servicing too will become much more time consuming than necessary. However, if control circuit diagrams are prepared along with the contract drawings in order to make the total system clearly visible then the essential points relating to the electrical connections will be easily understood, the test run will go off without a hitch and the whole system will be rendered fully effective.

Step 1: Compiling a System List (example using Inverter K Series)

1. Mark each outdoor unit with a code.
2. Add field settings and data for outdoor units, and outdoor unit No. if using sequential start.
3. Add the model number of each indoor unit connected to each refrigerant circuit.
4. Assign each indoor unit a code.
5. Fill in the location of each indoor unit.
6. Group indoor units controlled by one or two remote controls. (group or individual control).
7. Assign central group Nos. if using centralized control.
8. Add field settings and optional equipment for indoor units.
9. Add unit No. if making separate field settings for each indoor unit under group control.



Note: With the R-407C PLUS Series, unit No. is determined through automatic addressing, therefore readout unit Nos. after activating the power.

Example: System list

Outdoor Unit		Indoor Unit						
Model Name (code)	Field Settings	Model Name	System Name	Location	Remote Control Group	Centralized Control Group No.	Unit No.	Optional equipment, field settings, etc.
RSXYP16K (PAC1)	Cool/Heat selector: Indoor unit Low noise operation (L.N.O.P): Individual control Sequential start: ON Defrost: Earlier Sequential start No.	FXYCP32K	2F01	2nd floor office	A	1-00		
		FXYCP63K	2F02	2nd floor office	A	(1-00)		
		FXYCP40K	2F03	2nd floor office	A	(1-00)		
		FXYCP63K	2F04	2nd floor office	B	1-01		
		FXYCP50K	2F05	2nd floor office	B	(1-01)		
RSXYP18K (PAC2)	Cool/Heat selector: Indoor unit Low noise operation (L.N.O.P): Individual control Sequential start: ON Defrost: Earlier	FXYCP32K	3F01	3rd floor office	C	1-02		
		FXYCP40K	3F02	3rd floor office	C	(1-02)		
		FXYCP50K	3F03	3rd floor office	C	(1-02)		
		FXYCP50K	3F04	3rd floor office	D	1-03		

For details on field settings and centralized control group No., refer to the installation manual and system reference materials.

Step 2: Preparation of the Control Circuit Diagrams

The following sequence should be followed in order to prepare control circuit diagrams in accordance with the system list which has already been completed:

- ① Diagrams should be prepared for each individual outdoor unit. The outdoor unit model number should be inserted into the diagram. (RSXYP16K)
 - ② Insert name of refrigerant system. (PAC1, PAC2)
 - ③ Insert name of indoor unit. (FXYCP32K→C32K)
 - ④ Insert system name of indoor unit.
 - ⑤ Insert installation position. (Do this when demarcation is possible)
 - ⑥ Insert remote control control wiring. (Group) Indicated by solid line.Solid line.
 - ⑦ Insert centralized control wiring.Dotted line
 - ⑧ Insert Group No. (GNo. for each indoor unit with UNo. 0)
- The control circuit diagrams are now complete.

Example: Control circuit diagram

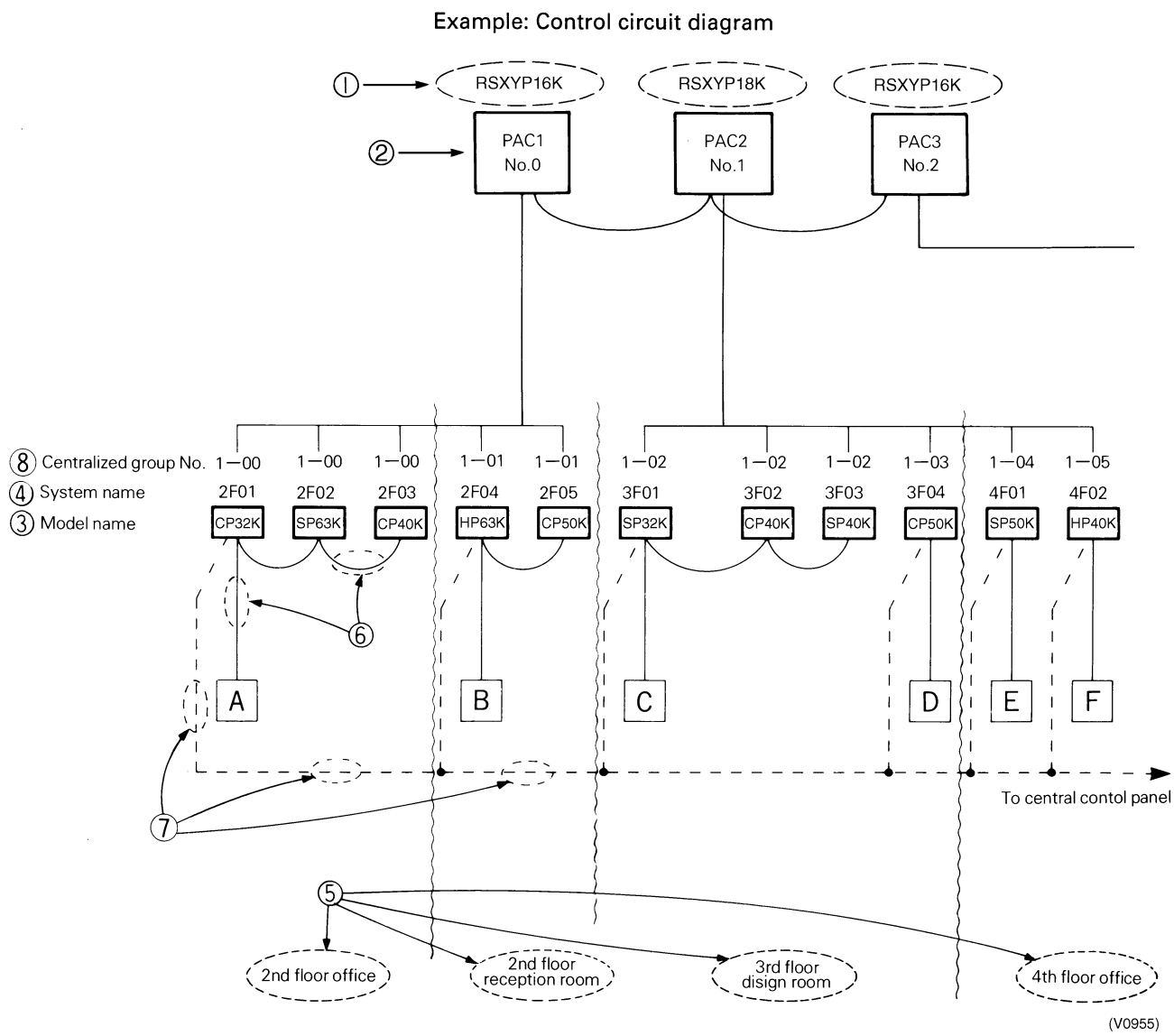

3. Installation

3.1 Step by Step Installation Procedure

	<Operations>	<Points>
Prework	Determination of division of work	Indicate clearly who is to be responsible for switch settings
	Preparation of contract drawings	Make relationship between outdoor, indoor, remote controller and option connections clear. (Prepare control circuit diagrams)
Work	Sleeve and insert work	Take account of gradient of drain piping
	Installation of indoor unit	Check model name to make sure the fitting is made correctly
	Refrigerant piping work	Special attention to dryness, cleanness and tightness
	Drain pipe work	Adjust to downward gradient
	Duct work	Make sure airflow is sufficient.
	Heat insulation work	Make sure no gaps are left where the insulating materials are joined
	Electrical work (connection circuits and drive circuits)	Multiple core cable must not be used. (Suitable cable should be selected)
	Setting of indoor unit setting switches	Must be carried out in strict accordance with control circuit diagrams
	Outdoor unit foundation work	The foundation must be level
	Installation of outdoor unit	Avoid short circuits and ensure sufficient space is allowed for servicing
	Setting of outdoor unit setting switch	Must be carried out in strict accordance with control circuit diagrams (Sequence start, low noise input, Cooling/Heating selection refrigerant piping length etc.)
	Air tight test	In the final check for 24 hours at 3.20 MPa there must be no drop in pressure
	Vacuum drying	The vacuum pump used must have a capacity of reaching at least 5 mmHg
	Additional charge of refrigerant	Make sure there are no gaps left between the facing materials used on the ceiling
	Fit facing panels	Make sure there are no gaps left between the facing materials used on the ceiling
	Test run adjustment	Run each indoor unit in turn to make sure the pipework has been fitted correctly
	Transfer to customer with explanation	Explain the use of the system as clearly as possible to your customer and make sure all relevant documentation is in order

(V1351)

The above list indicates the order in which the individual work operations are normally carried out but this order may be varied where local conditions warrant such a change

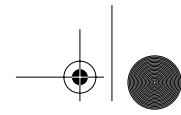

3.2 Work Involved in Individual Operations and Points to be Borne in Mind

3.2.1 Sleeve and Insert Work

■ Operational steps

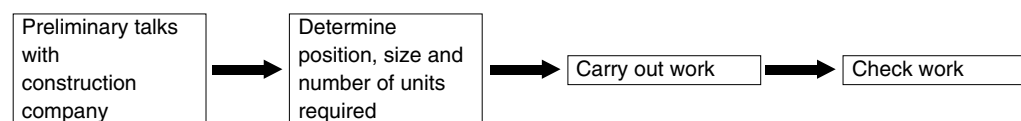

(V0957)

Positioning of the Pipe Holes

- a) The through holes for the drain piping should be positioned such that the pipes have a downward gradient. (The gradient must be at least 1/100. The thickness of the insulating materials must also be taken into consideration.)
- b) The diameter of the through holes for the refrigerant piping should include an allowance for the thickness of the heat insulation materials. (It is a good idea to think of the liquid and gas pipes as pairs.)
- c) Attention should be paid to the construction of the beam themselves since there are sometimes parts of the beam which cannot be used to accommodate through holes.

Example: Through holes in a reinforced concrete beam

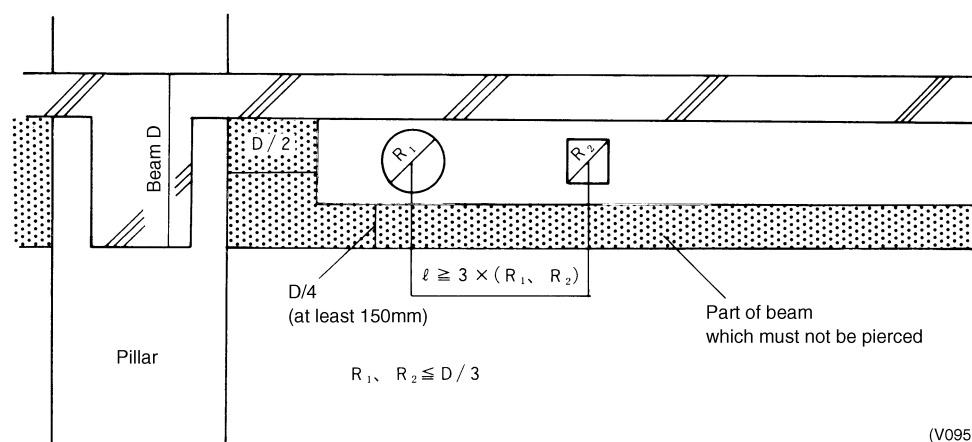

(V0958)

Positioning the Insert

- a) An insert is a metal tool which is inserted into a floor or a beam before the concrete is set such that fittings such as ducts, pipes or suspension bolts for hanging units can be fitted into place later. **The positions of the inserts must be decided early.**

Example: Steel insert

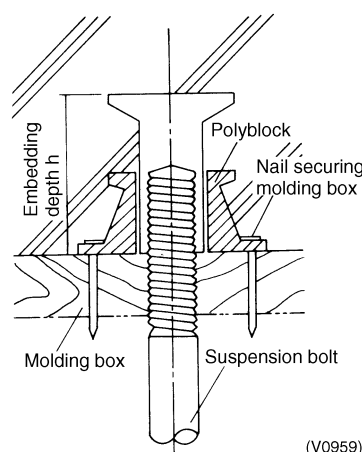

(V0959)

Important point:

- 1. The weight of the fitting to be suspended must be taken into account when choosing the insert.

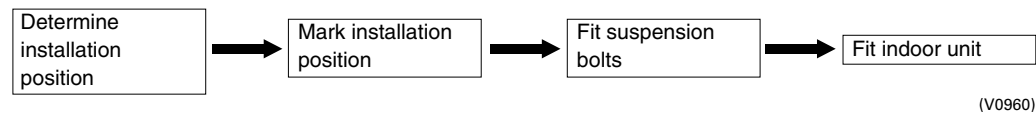
Installation**SiE33-003****3.2.2 Installation of Indoor Unit****■ Operational steps**

(V0960)

Positioning

3 essential points when installing an indoor unit

1. Height: Take care to account for final ceiling facing surface level
2. Level: Level fitting is essential. (within ± 1 degree of horizontal)
3. Direction: The unit must be fitted in line with the ultimately visible ceiling joints

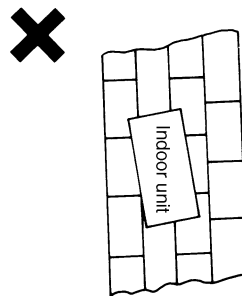
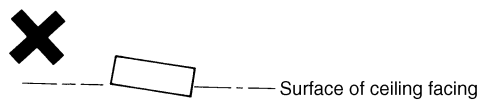
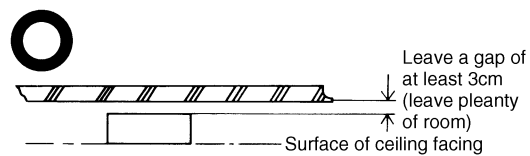

(V0961)

Important points

1. The suspension bolts must be strong enough to support the weight of the indoor unit.
2. Optional features must be added to the indoor unit prior to installation.
3. The model name should be checked prior to installation.
4. Take care to align the main unit correctly. (Bearing in mind piping layout and direction of blow out)
5. Leave sufficient space for servicing to be carried out.
6. Make inspection holes for model which need them.
7. Fit the unit to ensure proper drainage.

Example: Ceiling mounted cassette type (FXYCP63K)

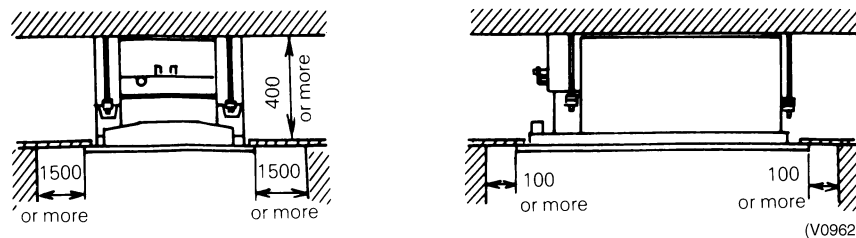

(V0962)

3.2.3 Refrigerant Pipe Work

■ Operational steps

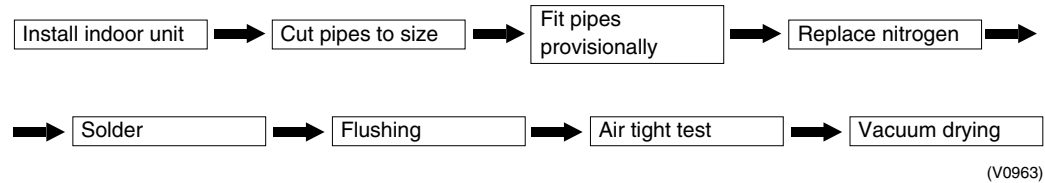

The 3 Principles of Refrigerant Piping

The "3 principles of refrigerant piping" must be strictly observed

	Cause of problem	Actoin to avoid problem
Dry	<ul style="list-style-type: none"> ● Rainwater, work water, etc. gets into pipes from outside ● Moisture generated inside pipes due to condensation 	Pipe covering → Flushing → Vacuum drying
Clean	<ul style="list-style-type: none"> ● Formation of oxides inside pipes during soldering ● Dirt, dust or other extraneous material gets into pipes from outside 	Replace nitrogen → Flushing Pipe covering → Flushing
Air tight	<ul style="list-style-type: none"> ● Leak from soldered area ● Leak from flared area ● Leak from flange area 	Use the proper materials (copper pipe, solder, etc.) Adhere strictly to standard soldering work practice Adhere strictly to standard flaring work practice Adhere strictly to standard flange connection work parctice → Air tight test

(V0964)

The 3 principles of refrigerant piping

Dry	Clean	Air tight
Make sure there is no moisture inside the pipes	Make sure there is no dirt inside the pipe	Make sure the refrigerant does not leak out
<p style="text-align: right;">(V0965)</p>	<p style="text-align: right;">(V1148)</p>	<p style="text-align: right;">(V1149)</p>

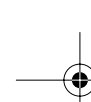

Method for Replacing Nitrogen (Brazing)

If brazing work is carried out without passing nitrogen gas through the pipes which are being brazed then this allows the formation of oxidation bubbles on the inside surface of the pipes. These oxidation bubbles are then carried along inside the pipes to cause damage to various members of the system such as valves or compressors and the system ceases to function properly.

In order to avoid this problem **nitrogen is passed through the pipes while the soldering work is being carried out**. This operation is known as nitrogen replacement. (Air is replaced by nitrogen)

This is **standard work practice for all brazing work**.

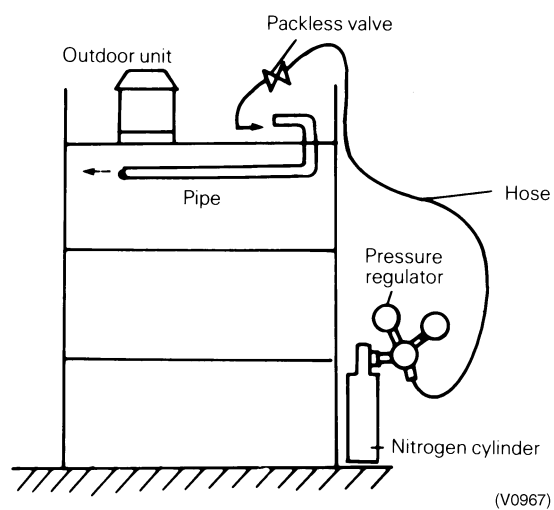
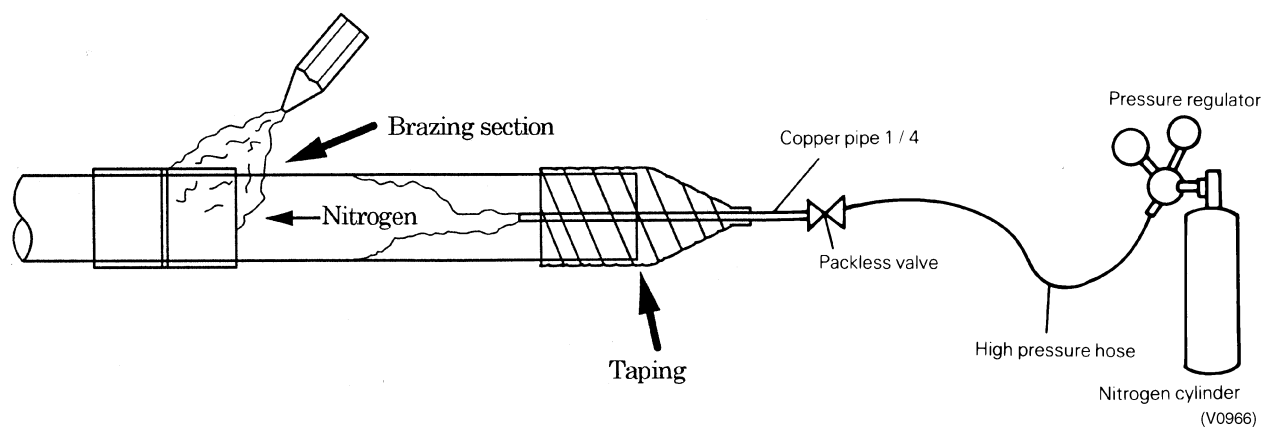

Important points:

1. The gas used must be nitrogen (oxygen, carbon dioxide and flon should not be used.)
2. A pressure regulator must be used.



Covering of Refrigerant Pipes

Covering is an extremely important operation as it prevents water, dirt or dust from getting inside the pipes. Moisture inside the pipes was a constant source of trouble in the past. The utmost care is required to nip this problem in the bud.

The end of each pieces of pipe must be covered. "Pinching" is the most effective method but "taping" is an simple alternative which may be used according to the work area and term of work.

Location	Term of Work	Covering Method
Outdoors	1 months or more	Pinching
	Less than 1 months	Pinching or taping
Indoors	Irrelevant	Pinching or taping

1. Pinching method
The end of the copper pipe is squeezed together and the gap brazed.
2. Taping method
The end of the copper pipe is covered with PVC tape (vinyl tape).

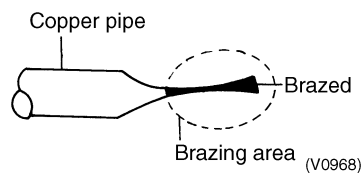

<Taping method>

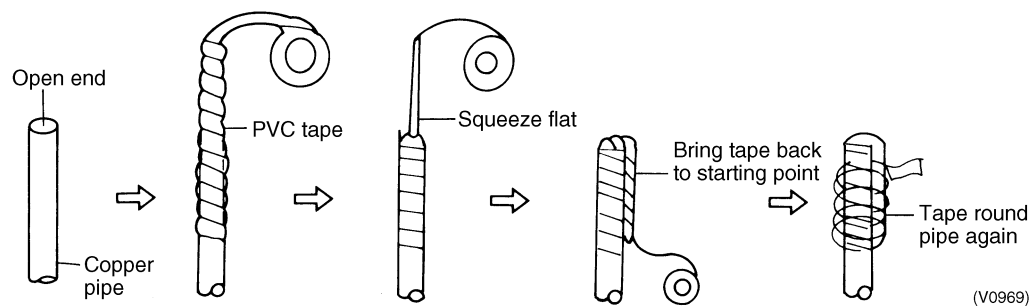

Particular care should be taken during the following operations:

- When passing copper pipe through a penetration hole (Dirt easily gets into the pipe).
- When copper pipe is located outside (Rainwater gets in)
(Special care is needed when the pipes are standing vertically outside)

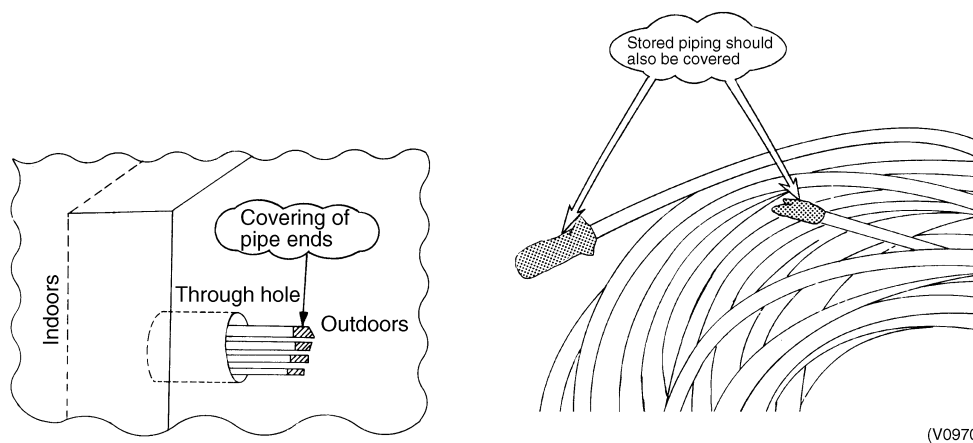

Refrigerant Pipe Flushing

Flushing is a method of cleaning extraneous matter out of pipes using pressurized gas.

[3 major effects]

1. Removal of oxidation bubbles formed inside copper pipes when "nitrogen replacement is insufficient" during soldering work
2. Removal of extraneous material and moisture from pipes when covering has been insufficient
3. Checks connections in pipes linking outdoor and indoor units (Both liquid and gas pipes)

[Example of procedure]

1. Set pressure regulator on nitrogen cylinder.
*The gas used must be nitrogen.
(There is a danger of condensation if fluor or carbon dioxide are used and oxygen carries the risk of explosions.)

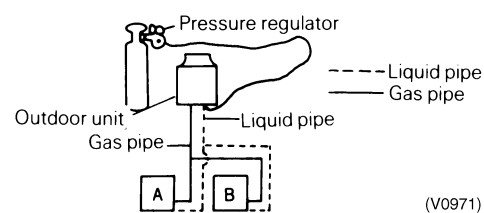

2. Connect the charge hose from the pressure regulator to the service port on the liquid pipe side of the outdoor unit.
3. Fit blanking plugs to all indoor units (B) other than unit A.

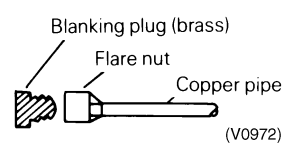

4. Open the main valve on the nitrogen cylinder and set the pressure regulator to 0.5MPa.

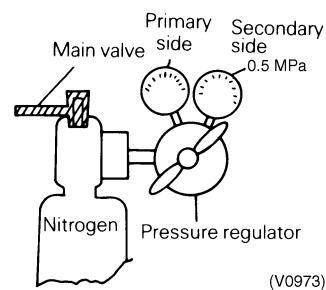

5. Check that the nitrogen is passing through the unit A liquid pipe.
6. Flushing.
 - Block the end of the pipe with the insulation of your hand.
 - ↓
 - When the gas pressure becomes too great to contain remove insulation quickly. (First flush)
 - ↓
 - Block the end of the pipe with insulation again.
 - ↓
 - (Carry out second flushing)

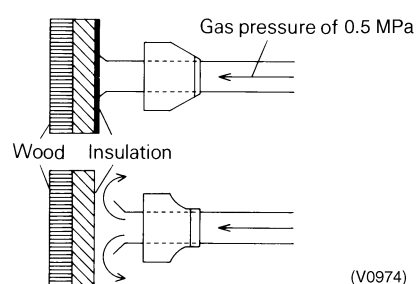

(The nature and amount of the extraneous material inside the pipe can be checked during flushing by placing a rag lightly over the end of the pipe. In the unlikely case that even a small quantity of moisture is found then the inside of the pipe should be dried out thoroughly.)

Action:

1. Flush the inside of the pipe with nitrogen gas. (Until such time as the moisture disappears.)
2. Carry out a thorough vacuum drying operation. (See page 29)
 - ① Close the main valve on the nitrogen cylinder.
 - ② Repeat the above operation for unit B.
 - ③ When the liquid pipe operations have been completed then do the same with the gas pipes.

Choice of Materials for Refrigerant Piping

a) Refrigerant piping

- The piping used must meet the requirements of the JIS standard or equivalent. (Size, material, thickness, etc.)

Specification: **Oxidized phosphorous seamless copper pipe**

- Long pipe lengths or coiled pipe (copper pipe with heat insulation coating) should be used to avoid the necessity for frequent brazing.
- The whole job is made easier if rolled copper pipe with a heat insulation coating is used.









Size of Refrigerant Piping

Outside Diameter (mm)	Wall Thickness (mm)
6.4	0.8
9.5	0.8
12.7	0.8
15.9	1.0
19.1	1.0
22.2	1.2
25.4	1.2
28.6	1.2
31.8	1.2
34.9	1.3

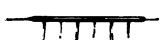
b) Brazed joints and special branches

1. General use (L bend joint, socket joint, T joint, etc.)
 - Joints must meet the requirements of the relevant JIS standard. (Size, materials, thickness, etc.)
2. Special branches
 - The Daikin REFNET joint or REFNET header should be used.

Example: R-407C PLUS Series

	REFNET joint	REFNET header		
		4 branches	6 branches	8 branches
Liquid pipe (with heat insulation coating)				
Gas pipe (with heat insulation coating)				

(V0975)



Refer detail of DAIKIN REFNET joint and REFNET header on page 100.

c) Brazing

The Multi-System requires only copper/copper jointing and the jointing method is explained below.

- The use of "hard solder" is essential.

Type	Solder: JIS mark	Soldering temperature (°C)	Breaking strength (kg/mm ²)	Soldering method	Jointing distance (mm)	Example for reference (product name)	Flux (example for reference)	Remarks
Hard solder	BCup-2 (Phosphor copper solder)	735 / 840	Approx. 25	0.05 / 0.2	Gas	NEiS # 2BD	Not required	BCup reacts easily with sulfur to form a fragile water-soluble compound and should not therefore be used where the environment is not suitable.
	BAG-2 (Silver solder)	700 / 845	Approx. 20	0.05 / 0.2	Gas	NEiS # 107	NEiS # 103	Suitable for environments with a high sulfur content

This is used under normal conditions.
(V0976)

The R-407C Plus Series uses a wide range of piping sizes. You should therefore be careful when selecting the nozzle tip. If a small nozzle tip is used for brazing piping of large diameters such as $\phi 38.1$ and $\phi 44.5$, brazing flow becomes poor.

Table 1: Correlation of nozzle tip and size of refrigeration piping

Piping size	Nozzle tip No.							Brazing filler diameter ϕ		
	# 200	# 225	# 250	# 315	# 400	# 450	# 500	1.6	2.4	3.2
6.35										
9.53										
12.7										
15.9										
19.1										
22.2										
25.4										
31.8										
38.1										
44.5										

(V0977)

i Note: The values in the table above are for type B torch (French).

Brazing

- a) Brazing work should be carried out such that the final result is directed either downwards or sideways. An upward direction should be avoided wherever possible. (to prevent leakage)

<Recommended method>

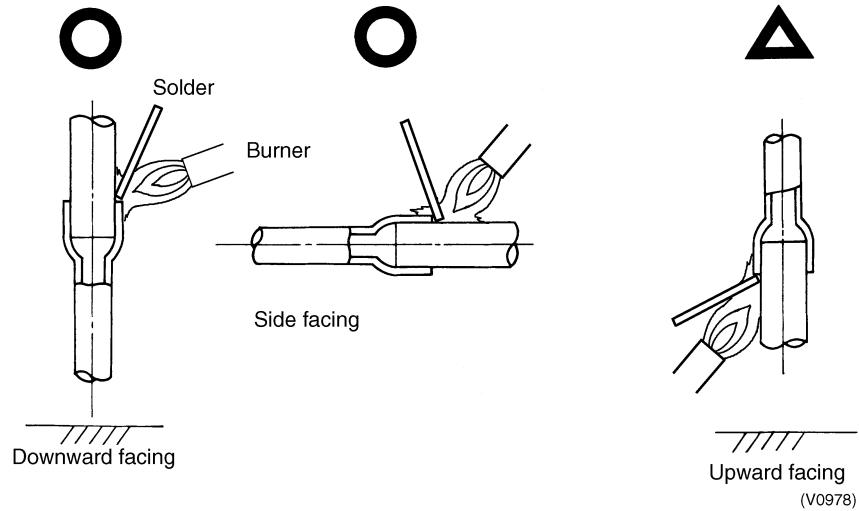

- b) Liquid and gas pipe branches should always be dealt with in the specified way with attention being paid to the direction of the fitting and its angle. (to prevent oil return or drift) For example see page 119.
 c) It is standard working practice to use the nitrogen replacement method when brazing.

Important points

1. Every effort must be made to avoid fire. (Clean area where brazing is to be performed and make sure that fire fighting equipment and water are ready to hand.)
2. Be careful of burns.
3. Make sure that the gap between the pipe and the joint is correct. (To prevent leaks)
4. Is the pipe adequately supported?

- As a rule the gaps between supports for horizontal piping (copper pipe) are as follows:

Copper pipe support spacing		(From HASS 107-1977)		
Nominal diameter	20 or less	25~40	50	
Maximum gap (m)	1.0	1.5	2.0	

- The copper pipe should not be secured directly by metal brackets.

Flare Connection

- (a) Stiffened pipe must always be annealed at least once prior to the flaring work.
- (b) A pipe cutter must be used to cut the pipe. (A large pipe cutter must be used where the pipe has a large diameter. When cutting a pipe which is too big for the pipe cutter a metal saw may be used but care must be taken to ensure that the debris from sawing does not get into the pipe.)
- (c) Set the flaring tool to make sure the flare size remains within the prescribed limits.

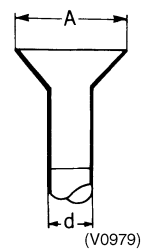

Nominal diameter	External diameter of pipe d	Pipe widening dimensions A
3/8B	9.53	12.2~12.8
1/2B	12.7	15.6~16.2
5/8B	15.88	18.8~19.4
3/4B	19.05	23.1~23.7

- (d) Coat the inner and outer surface of the flare with refrigerator oil (Ester or ether oil). (this ensures that the flare nut passes smoothly, preventing the pipe from twisting.)
Do not use SUNISO-4GS oil.

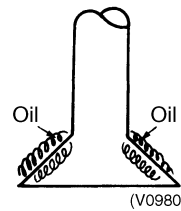
**Important points**

- Burrs should be carefully removed.
- 2 spanners should be used to grip the pipe.
- The flare nut must be inserted before starting the flaring operation.
- The appropriate amount of torque should be used to tighten the flare nut.

Standard torques for tightening flare nut $\pm 10\%$

Size	Torque	
	(kgf-cm)	(N-cm)
1/4(6.4φ)	144~176	1420~1720
3/8(9.5φ)	333~407	3270~3990
1/2(12.7φ)	504~616	4950~6030
5/8(15.9φ)	630~770	6180~7540
3/4(19.1φ)	990~1210	9270~11860

- Check that there is no superficial damage to the surface of the flare.

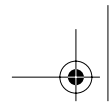

Flaring Procedure

- ① Cut the pipe using a pipe cutter.

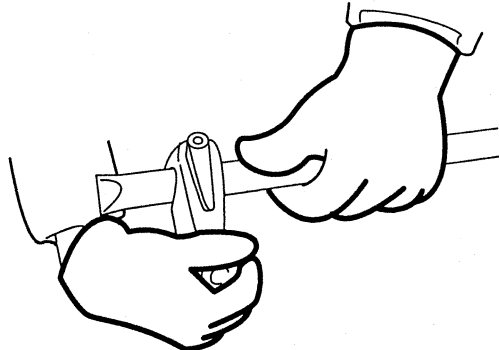

- ② The cut edge has burrs.
(The amount of burrs becomes larger when the pipe wall is thick.)

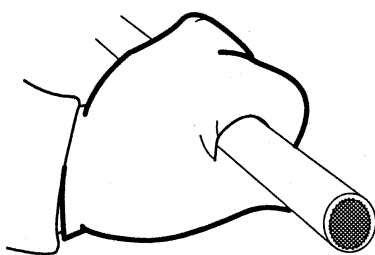

- ③ Remove the burrs using a file.
(Be careful not to let particles enter the pipe. Point the pipe end downward during filing.)

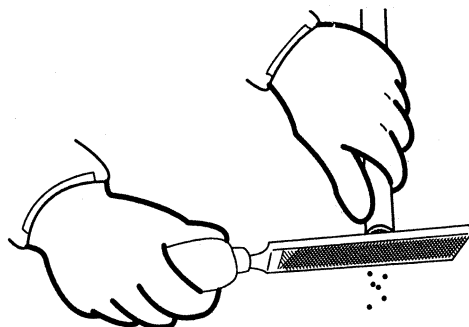

- ④ Remove the burrs using a knife
(Be careful not to let particles enter the pipe. Point the pipe end downward during cutting.)

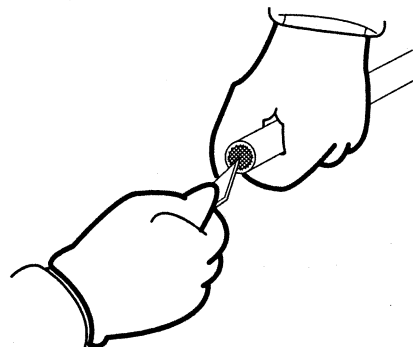

- ⑤ Clean the inside of the pipe.
(Use a thin stick with a cloth wrapped around it.)

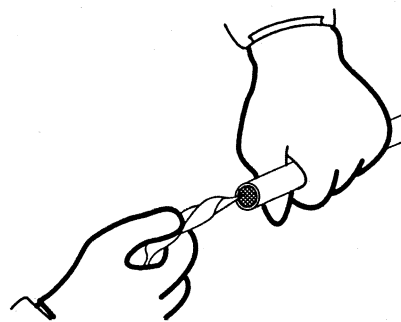

- ⑥ Before flaring, clean the cone section of the flaring tool.

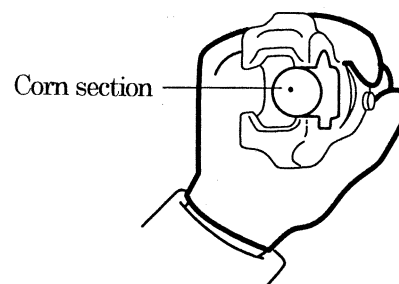

- ⑦ Flare the pipe.
Rotate the flaring tool 3 or 4 turns after a clicking sound is produced. This results in a clean flared surface.

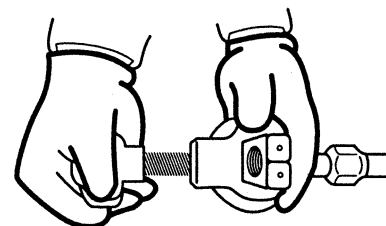

- ⑧ Apply refrigerant oil (Ester or ether oil) on the inside and outside of the flared section. (Do not apply SUNISO oil.)
(Be careful to keep dust away.)

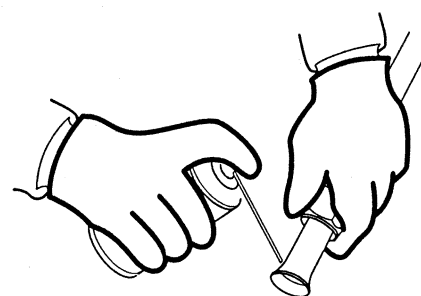

(V1352)

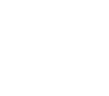
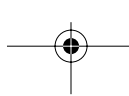

- ⑨ Tighten the flare nut.
(Use a torque wrench to apply the proper tightening force.)

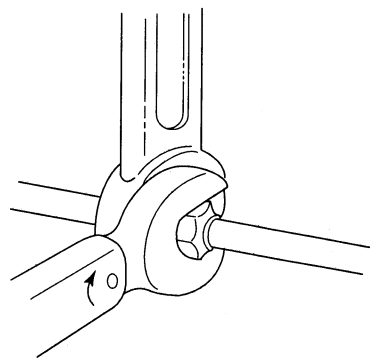

- ⑩ Check for gas leaks.
(Check at the threaded section of the flare nut for gas leaks.)
Spray-type gas leak detecting products are available on the market. Soap water may be used to check for leaks, but use only neutral soap to prevent corrosion of the flare nut. Be sure to wipe the nut area clean after the gas leak check.

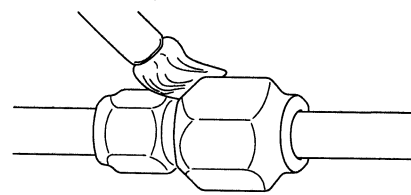

Tighten the flare nut with proper torque.
It takes a lot of experience to tighten the flare nut properly without the use of a torque wrench.

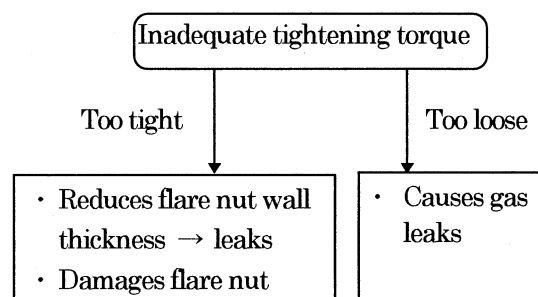

(V0984)

Not recommendable but in case of emergency

You must use a torque wrench but if you are obliged to install the unit without a torque wrench, you may follow the installation method mentioned below.

After the work is finished, make sure to check that is no gas leak.

When you keep on tightening the flare nut with a spanner, there is a point where the tightening torque suddenly increases. From that position, further tighten the flare nut the angle shown below:

Pipe size	Further tightening angle	Recommended arm length of tool
6.4 (1/4")	60 to 90 degrees	Approx. 150mm
9.5 (3/8")	60 to 90 degrees	Approx. 200mm
12.7 (1/2")	30 to 60 degrees	Approx. 250mm
15.9 (5/8")	30 to 60 degrees	Approx. 300mm
19.1 (3/4")	20 to 35 degrees	Approx. 450mm

Flange Connection

- a) The flange sheet surface should be clean and undamaged. (Clean any dirt away with a cloth and check that there has been no damage.)
- b) Coat the flange sheet surface with refrigeration oil (Ester or ether oil) and then insert the packing. (Do not use SUNISO oil.)

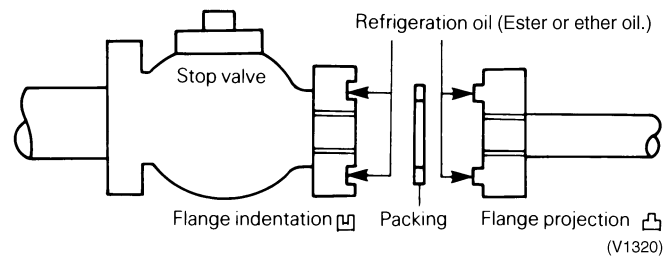

- c) Tighten the bolts in opposite corners first to ensure that the connection is true.

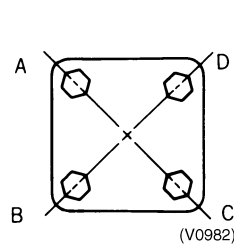

[Example]

Order: A→C→B→D

The bolts should be tightened little by little in the above order such that the same degree of torque is applied evenly to each corner.

Important points

- 1. Only clean refrigeration/oil should be used to coat the flange. (i.e. free from dirt or water)
- 2. The correct amount of torque should be applied when tightening the flange bolts.

Standard torques for tightening screws and bolts

ISO hexagonal bolt

Size	Class	5.8(5T)		10.9(10T)	
		kgf-cm ±15%	N-m ±15%	kgf-cm ±15%	N-m ±15%
M8		125	1230	302	2960
M10		257	2520	620	6080
M12		436	4280	1,050	10,300
M16		1,030	10,100	2,480	24,300
M20		2,050	20,100	4,950	48,500

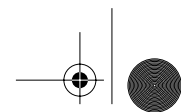

3.2.4 Thermal Insulation Work (Refrigerant Piping)

Operational steps

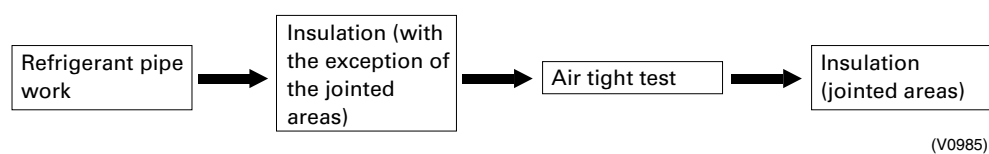

(V0985)

Materials

The thermal insulation materials which are used must be well able to withstand the heat from the pipes.

Example:

Heat pump type: Heat resistant polyethylene foam (heat resistance of at least 120°C)

Cooling only: Polyethylene foam (heat resistance of 100°C or more)

Essential Points of Thermal Insulation

The insulation of jointed areas such as the soldered, flared or flanged sections should only be carried out after the successful completion of the air tight test.

Attention should be paid to the unit model and its operating conditions since there are occasions when the gas and liquid pipes also need to be thermally insulated.

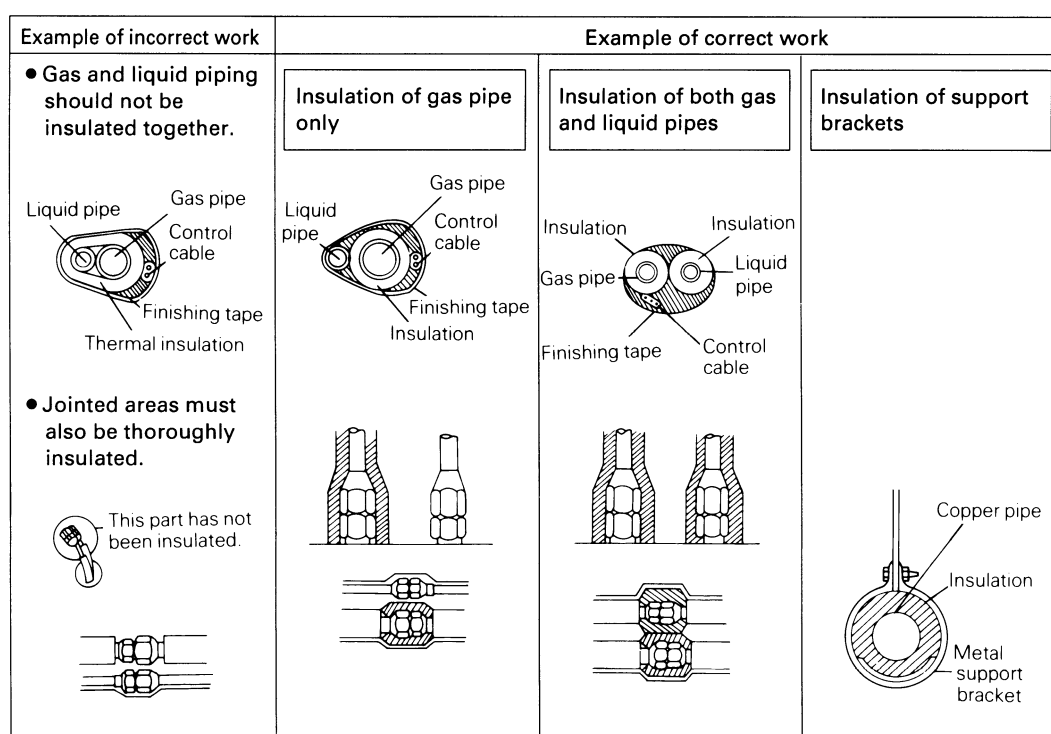

(V0986)

Important points

1. The thickness of the thermal insulation material must be determined in the light of the pipe sizes.

Pipe size	Thickness of insulation material
6.4mm~25.4mm	10mm or more
28.6mm~38.1mm	15mm or more

2. It will be necessary to increase the values in the above table for top floors or where conditions are hot and humid.

3. Where a customer supplies his own specifications then these must be adhered to.

4. Where it is anticipated that the air conditioning unit will be operated at external air temperatures of 10°C or less then thermal insulation will also be required for the liquid pipes.

3.2.5 Air Tight Test

Operational steps

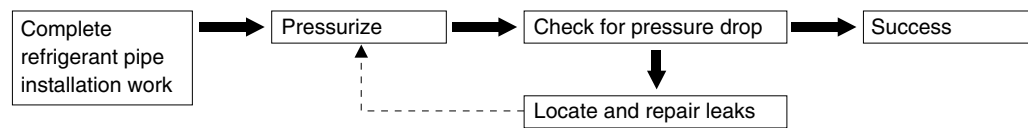

(V0987)

Essential Points of Testing (Maintaining Pressure Over a Period)

The key to successful testing is strict adherence to the following procedure:

a) The liquid and gas piping in each refrigerant system should be pressurized in turn in accordance with the following steps. (Nitrogen gas must be used.)

- **Step 1: increase pressure to 0.3MPa for 3 minutes or more**
 - **Step 2: increase pressure to 1.5MPa for 3 minutes or more**
 - **Step 3: increase pressure to 3.20MPa for approx. 24 hours**
- } Indicates existence of major leaks
- } Indicates existence of minor leaks

*Increasing the system pressure to 3.20MPa does not guarantee the identification of minor leaks if pressure is maintained for only a short time. It is therefore recommended that the system remain pressurized in accordance with Step 3 above for at least 24 hours.



Note: The pressure must on no account be increased beyond 3.20MPa.

b) Check for pressure drop

If there is no drop in pressure then the test is deemed a success.

If the pressure drops then the leak must be located. See following page.

However, if there is a change in the ambient temperature between the pressurizing stage and the time when you check for a drop in pressure then you will have to adjust your calculations accordingly since a change of 1°C can account for a pressure change of approximately 0.01MPa.

Compensating adjustment value:

(temperature at time of pressurizing – temperature at time of checking) × 0.1

Example:

Time of pressurizing: 3.20MPa 25°C

24 hours later: 3.15MPa 20°C

The pressure drop in such a case is deemed to be zero (successful test).

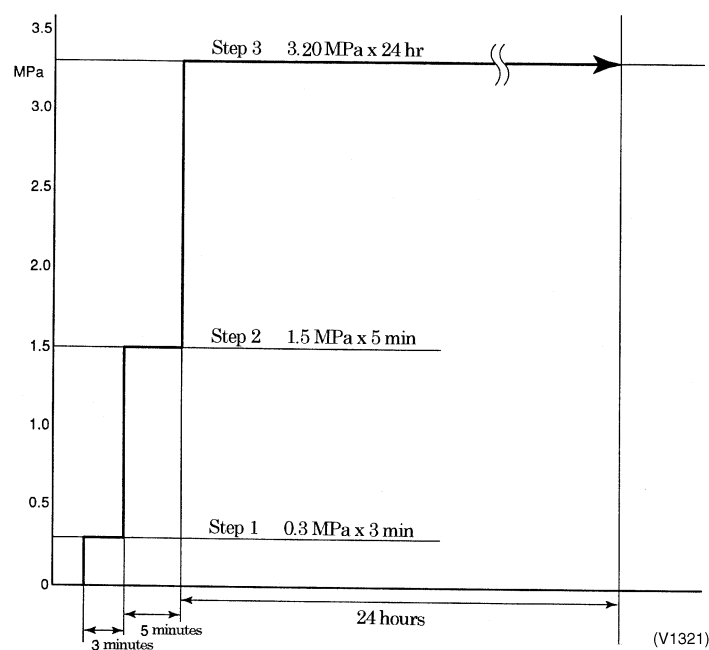

(V1321)

Checking for Leaks

[Check 1] (Where pressure falls while carrying out Steps 1 to 3 described on previous page)

- Check by ear.....Listen for the sound of a major leak.
- Check by hand.....Check for leak by feeling around jointed sections with hand.
- Soap and water check (*Snoop).....Bubbles will reveal the presence of a leak.

[Check 2] (When searching for a minor leak or when there has been a fall in pressure while the system has been fully pressurized but the source of the leak cannot be traced.)

1. Release the nitrogen until the pressure reaches 0.3MPa.
2. Increase pressure to 1.5MPa using gaseous flon gas (R-407C). (Nitrogen and flon gas mixed)
3. Search for the source of the leak using a detector such as a halide torch or a propane or electric detector.
4. If the source of the leak still cannot be traced then repressurize with nitrogen up to 3.20MPa and check again. (The pressure must not be increased to more than 3.20MPa.)

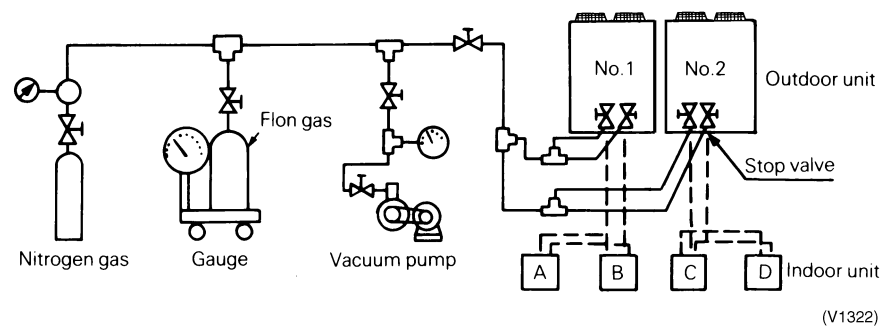
**Important points**

1. Where the lengths of piping involved are particularly long then the air tight test should be carried out block by block.

Example:

1. Indoor side
2. Indoor side + vertical pipes
3. Indoor side + vertical pipes + outdoor side



3.2.6 Vacuum Drying

What is vacuum drying?

Vacuum drying is:

“The use of a vacuum pump to vaporize (gasify) the moisture (liquid) inside the pipes and expel it leaving the pipes completely dry inside.”

At 1 atm (760 mmHg) the boiling point (evaporating temperature) of water is 100°C but if a vacuum is created inside the pipes using a vacuum pump then the boiling point is rapidly reduced as the degree of the vacuum is increased. If the boiling point is reduced to a level below that of the ambient temperature then the moisture in the pipes will evaporate.

Boiling point of water (°C)	Pressure		
	*cmHg	Pa	Torr
40	-70.5	7333	55
30	-72.4	4800	36
26.7	-73.5	3333	25
24.4	-73.8	3066	22
22.2	-74.0	2666	20
20.6	-74.2	2400	18
17.8	-74.5	2000	15
15.0	-74.7	1733	13
11.7	-75.0	1333	10
7.2	-75.2	1066	8
0	-75.5	667	5

<Example>
When outside temperature is 72°C
As shown in the table on the right, the degree of vacuum must be lowered below -75.2cmHg. →

Above figures (cmHg) are gauge pressure readings.

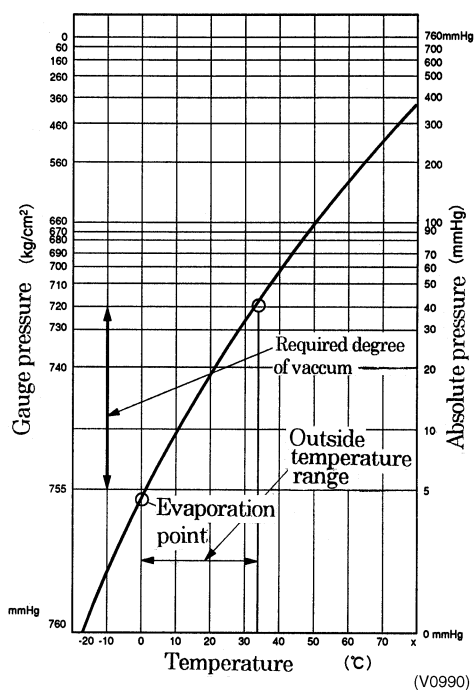

The evacuation of air conditioner piping provides the following effects.

1. Vacuum drying
2. Removes air and nitrogen (used in air-tightness test) from the inside of pipes.

Therefore, it is necessary to ensure that the both purposes have been achieved in the vacuum drying operation.

Key points
Lower the degree of vacuum to below -755mmHg

(V1216)

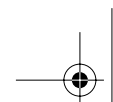
**Choosing a Vacuum Pump****General**

Refrigerant piping content volume of the Plus Series is larger than the VRV Inverter Series, and consequently takes more time for vacuum drying. If you have time to spare, you may use the same vacuum pump, but if you want to save time, you will have to use a pump with higher exhaust velocity (exhaust volume).

1. Vacuum pump performance

The 2 most important things for determining vacuum pump performance are as follows:

- (1) Exhaust velocity
- (2) Degree of vacuum

(1) Exhaust velocity

Exhaust volume is usually expressed as l/min or m³/h. The larger the number, the faster vacuum is achieved.

Generally speaking, the faster the exhaust velocity, the larger and heavier the vacuum pump itself is. Commercially available vacuum pumps (exhaust velocity of 20 - 30 l/min) usually take an extremely long time to achieve vacuum. (We recommend a vacuum pump of approx. 60 - 100 l/min.)

(2) Degree of vacuum

Ultimate vacuum varies largely according to use of the vacuum pump. Vacuum pumps used for vacuum forming cannot be used for vacuum drying. (A vacuum pump with a high degree of vacuum is required.)

When selecting a vacuum, you should select one which is capable of achieving 0.2 Torr of ultimate vacuum.

Degree of vacuum is expressed in Torr, micron, mmHg, and Pascal (Pa). The units correlate as follows:

	Unit	Standard atmospheric pressure	Perfect vacuum
Gauge Pressure	kg/cm ²	0	-1.033
Absolute Pressure	kg/cm ² abs	1.033	0
Torr	Torr	760	0
Micron	Micron	760000	0
*cmHg	cmHg	0	76
Pa	hPa	1013.33	0

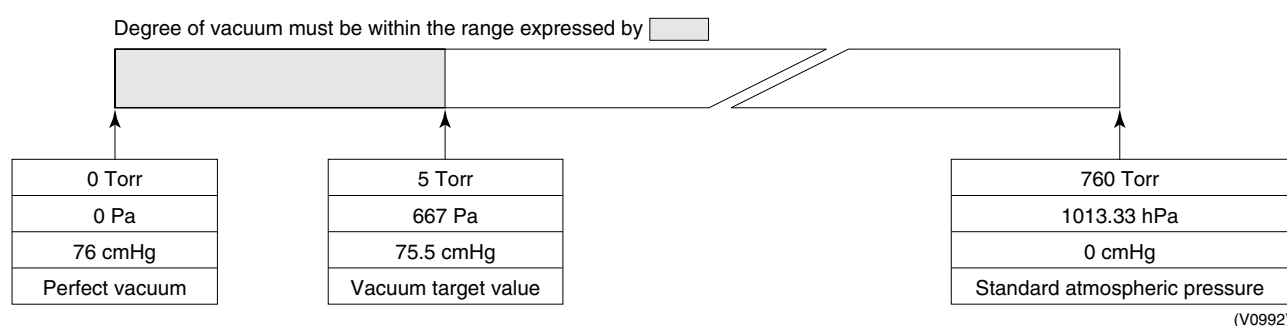

**2. Vacuum pump maintenance**

Because of their nature, most vacuum pumps contain large amounts of oil which lubricates bearings, etc., and functions to enhance airtightness of pistons. When using a vacuum pump to discharge air from refrigerant piping, moisture in the air tends to get mixed in with the oil. You must therefore change oil periodically and make sure the proper oil level is maintained. (Perform periodic inspections in accordance with the operating instructions.)

3. Degree of vacuum measurement

An extremely accurate vacuum gauge is required to test degree of vacuum. You cannot accurately measure degree of vacuum with the compound gauge on the gauge manifold. A Pirani vacuum gauge is required to measure degree of vacuum accurately. Because Pirani gauges are very sensitive and require extreme care when using, they are not very suitable for use in the field. You should therefore use the Pirani gauge to calibrate the attached vacuum gauge on the gauge manifold and the degree of vacuum of the vacuum pump.

4. Calibration method

1. Connect a Pirani vacuum gauge and the gauge manifold vacuum gauge (0 - 76 cmHg) to the vacuum pump at the same time, and run the pump for about 3 minutes.
2. Make sure the reading of the Pirani vacuum gauge is 5 Torr (667 Pa) or less. The reading of conventional vacuum pumps lowers to about 0.2 Torr.
If the reading is not 5 Torr or less, check the vacuum pump oil. (Oil is low in many cases.)
3. Check the attached gauge on the gauge manifold. Adjust the gauge if the reading is not exactly correct.
4. Adjust the gauge manifold valve so that the Pirani vacuum gauge reads 5 Torr.
5. Mark the position indicated by the gauge manifold gauge with an oil based ink pen.
6. Use the mark of the gauge manifold as a target when vacuuming in the field.

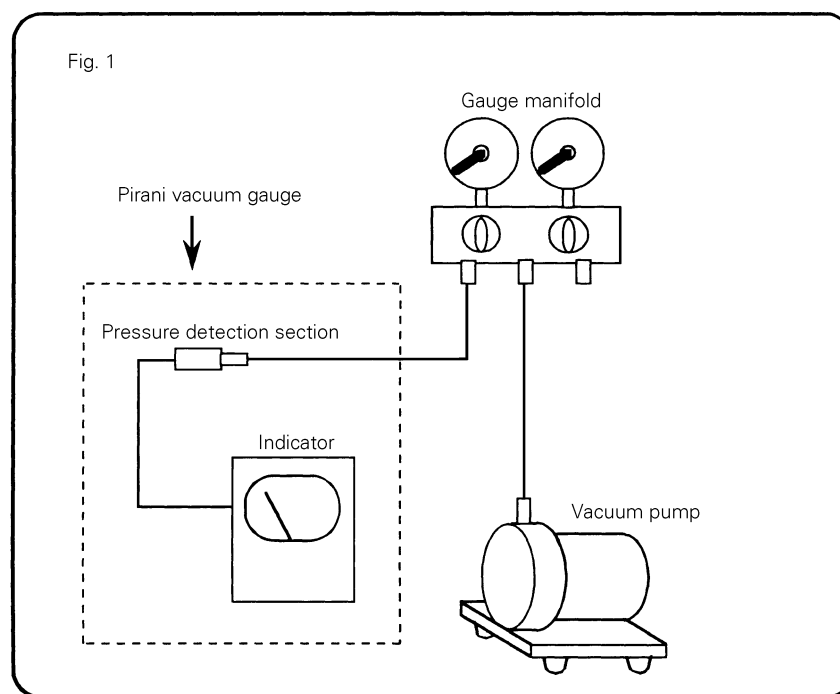

(V0993)

(Reference) Types of vacuum pump with respective maximum degree of vacuum

Type	Maximum Degree of Vacuum		Use	
	Expulsion Capacity		Vacuum Drying	Air Expulsion
Oil Rotary (Oil Using)	0.02 mmHg	100 l/min	Suitable	Suitable
Oilless Rotary (No Need of Oil)	10 mmHg	50 l/min	Unsuitable	Suitable
	0.02 mmHg	40 l/min	Suitable	Suitable

← Many handy pumps fall into this category

Vacuum Drying Procedure

There are two vacuum drying methods and the appropriate one should always be chosen to conform with individual local conditions.

[Normal vacuum drying].....The standard method

[Operational steps]

1. Vacuum drying (1st time): Connect a manifold gauge to the service port of the liquid or gas pipe and operate the vacuum pump for at least 2 hours.

(The degree of vacuum produced should be in excess of 5 mmHg)

If after 2 hours the vacuum produced has not exceeded 5 mmHg then either there is moisture in the pipe or there is a leak. Operate the vacuum pump for a further hour.

If, even after 3 hours, the vacuum has not reached 5 mmHg then check the system for a leak.

2. Carry out maintained vacuum test.

Produce a vacuum in excess of -755 mmHg and do not release it for an hour or more. Check the vacuum gauge to make sure that it has not risen. (If the gauge does rise then there is still moisture in the pipe or there is a leak somewhere.)

3. Additional charge of refrigerant.

Connect the charging cylinder to the liquid pipe service port and charge with the required amount of refrigerant.

4. Open stop valve to the full.

Open the stop valves on the liquid and the gas pipes to the full.

**Note:**

Vacuums should be produced in both the liquid and the gas pipes.

(Because there are a large number of functional components in the indoor unit which cut off the vacuum mid-way through)

[Standard vacuum drying time chart]

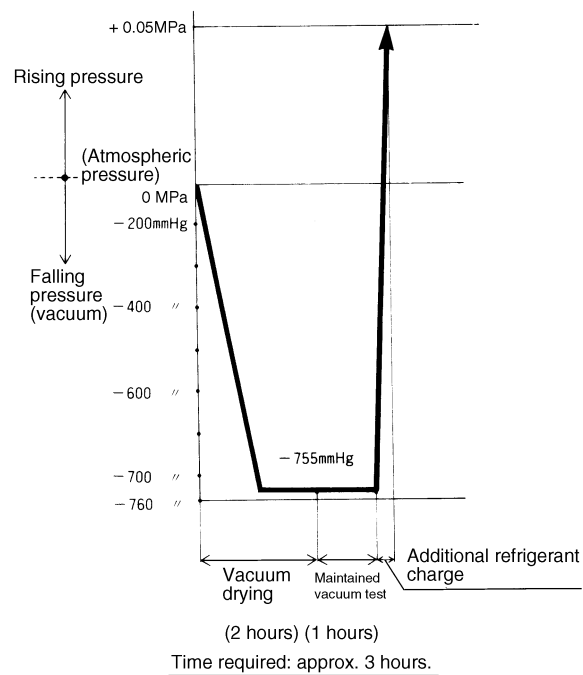

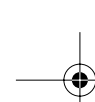

Special vacuum drying

This vacuum drying method is selected when there is a suspicion that there may be moisture in the pipes. For example:

- When moisture was discovered during the refrigerant pipe flushing operation
- When there is a risk of condensation forming inside the pipes during periods of heavy rainfall
- When there is a risk of condensation forming inside the pipes due to a long term of works
- When there is a risk that rainwater may have entered the pipes during installation

The special vacuum drying method is the same as the standard method except that nitrogen is introduced into the pipes to break the vacuum on one or more occasions during the course of the operation.

[Operational steps]

1. Vacuum drying (1st time): 2 hours
2. Vacuum breaking (1st time): Use nitrogen to raise pressure to +0.05MPa.
(Since the nitrogen gas used to break the vacuum is dry nitrogen this process serves only to enhance the overall drying effect of the vacuum drying operation itself.
However, since the effectiveness of this process is severely impaired by a high moisture level inside the pipes, the utmost care is required during installation to see that water does not enter or form inside the refrigerant pipes.)
3. Vacuum drying (2nd time): Operate the vacuum pump for at least 1 hour.
(Observations: Degree of vacuum has reached 5 mmHg. If the degree of vacuum has not reached 5 mmHg after 2 hours or more then repeat the operations at 2 (vacuum breaking) and 3 (vacuum drying) above.)
4. Carry out maintained vacuum test: 1 hour
5. Additional charge of refrigerant
6. Open stop valve to the full

- * The gas used for the vacuum breaking operation must be nitrogen.
(The use of oxygen brings a serious risk of explosions)

[Special vacuum drying time chart]

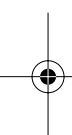
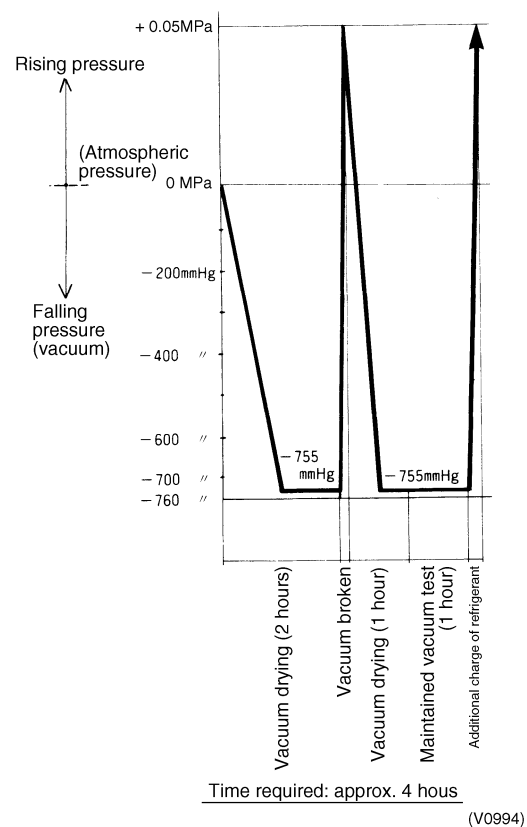

3.2.7 Additional Charge of Refrigerant

■ Operational steps

Use the length of the piping to calculate the amount of refrigerant required



Additional charge of refrigerant

(V0995)

Important points

1. The results of all calculations must be recorded. (Make a list.)
2. The refrigerant will need to be additionally charged whenever the distance between the outdoor unit and the most distant indoor unit is more than 10m.
3. The additional charging operation should be carried out by input of liquid into the liquid pipes from a charging cylinder following completion of the vacuum drying operation.
4. When the additional charging operation cannot be satisfactorily completed use the action of the compressor to complete the additional charging during the test run.

Refrigerant Charging Instructions

HFC407C are non-azeotropic* refrigerants. Therefore, these refrigerants must be charged in the liquid state. When charging the refrigerant into equipment from the cylinder, turn the refrigerant cylinder upside down.

Important: Make sure that the refrigerant (liquid) is taken out from the bottom part of the cooling cylinder. Do not take out the refrigerant (gas) at the upper part of the cooling cylinder for charging.

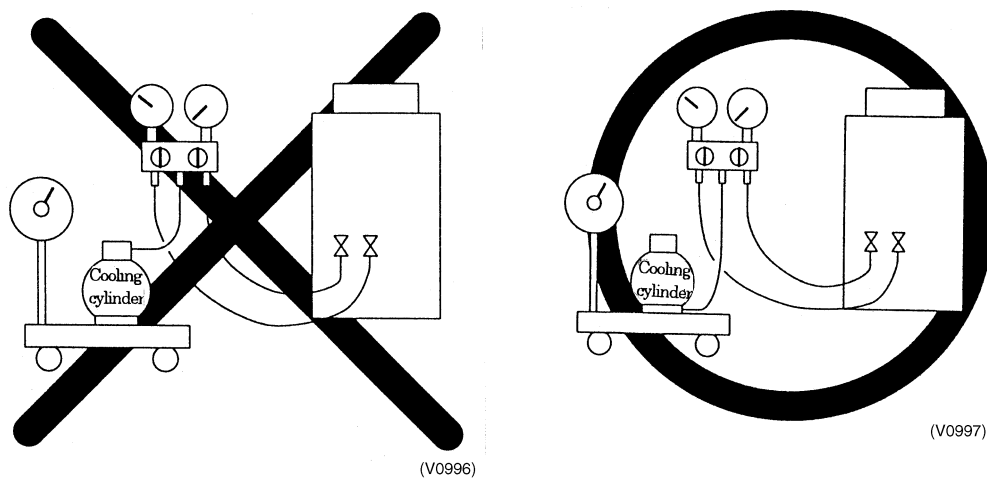

Caution

Since some cooling cylinders differ in the internal mechanism, it is necessary to examine the cylinder carefully. (Some cylinders have a siphon tube to eliminate the need for turning it upside down.)

Siphon tube

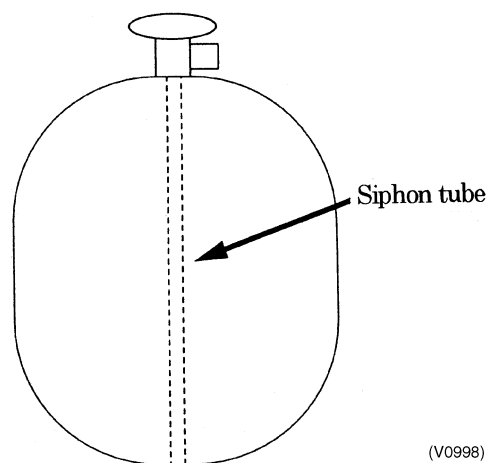

(V0998)

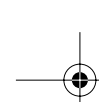

<*Non-azeotropic refrigerants>

When a refrigerant is a mixture of two or more types with different evaporation temperature, it is called a non-azeotropic refrigerant . If all refrigerant components evaporate at the same temperature, the mixture is called an azeotropic refrigerant .

If a non-azeotropic refrigerant is charged into equipment in the gaseous state, the refrigerant components that evaporate sooner than others enter the equipment, and the refrigerant that evaporate after others remain in the refrigerant cylinder.

Caution items

The following devices designed for R-22 cannot be used to charge the new refrigerants. Be sure to use the devices specifically designed for the new refrigerants.

1. Charging cylinder...(Pressure resisting specification is different.)
2. Gauge manifold (including hose)...(same as above)

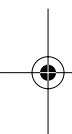

3.2.8 Drain Pipe Work Indoor units

■ Operational steps

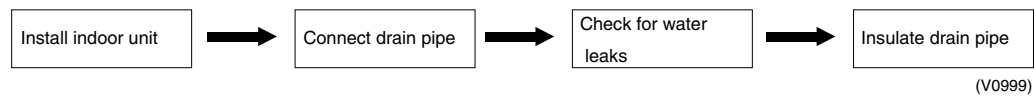

Drain Pipe Gradient and Support

- a) The drain pipe must be fitted at a gradient of at least 1/100. The drain pipe should be as short as possible and free from airlocks.

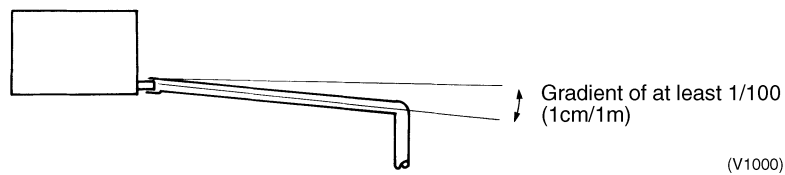

- b) Suspension bolts should be used to support long stretches of drain pipe in order to ensure that a gradient of 1/100 is maintained. (PVC pipes should not be bent)

Spacing of supports for horizontal piping

Class	Nominal diameter	Spacing
Rigid PVC pipe	25~40mm	1~1.5m

- c) The length of pipe laid horizontally should be kept to a minimum.

Drain Trap

Fit any indoor unit whose drain pipe connection is subjected to negative pressure, with a drain trap. (FXYMP40~125 only)

- a) Rig the drain trap as shown in the drawing bellow.

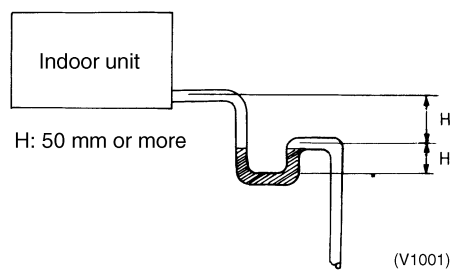

- b) Provide one trap per unit. A single trap for converging units will prove ineffective.

- c) Rig the trap to allow for future cleaning.

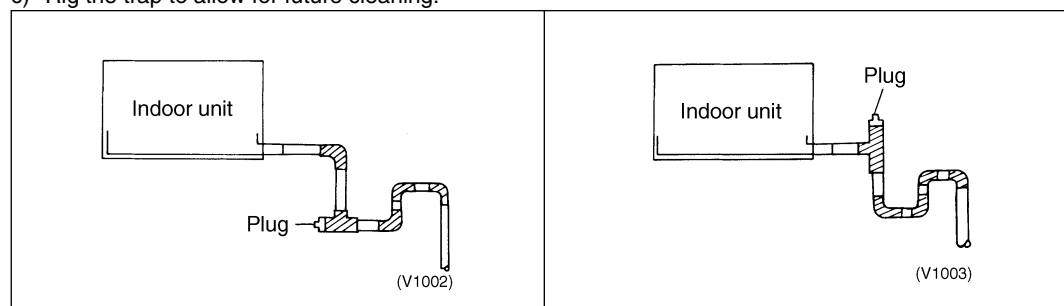

Grouped Drain Piping

1. It is standard work practice to make connections to the main pipe from above. The pipe down from the combination should be as large as possible.

Grouped drain pipes from multiple units

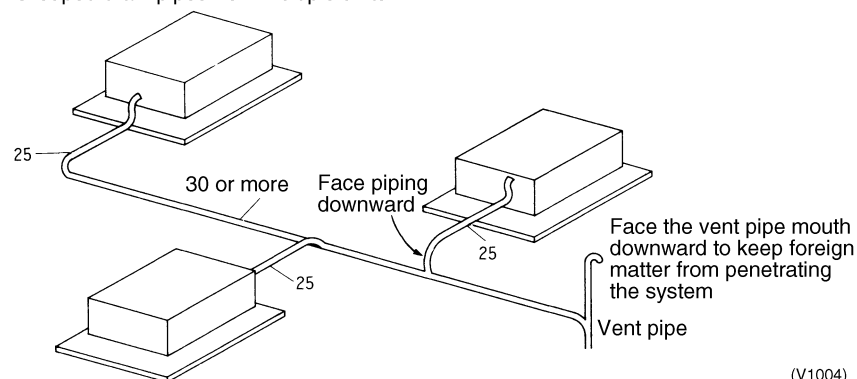

(V1004)

2. The pipework should be kept as short as possible and the number of indoor units per group kept to a minimum.

Use of an Auxiliary Drain Hose (Flexible)

If a drain pan made of polystyrene foam is used then an auxiliary drain hose (flexible) is also essential. A flexible drain hose permits the drain socket and drain pipe to be connected without difficulty and prevents any undue strain being placed on the drain pan.

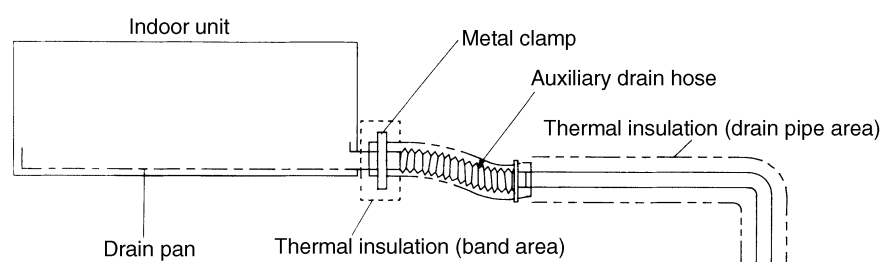

(V1005)

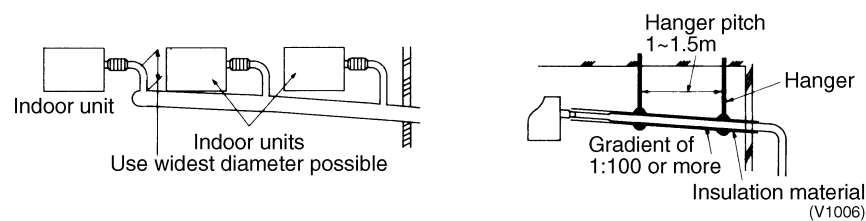

(V1006)

Important points

1. The drain pipe should be at least equal in size to that of the indoor unit.
2. The drain pipe is thermally insulated to prevent the formation of condensation inside the pipe.
3. The drain up mechanism should be fitted before the indoor unit is installed and when the electricity has been connected some water should be added to the drain pan and the drain pump checked to see that it is functioning correctly.
4. All connections should be secure. (Special care is needed with PVC pipe)
The use of a colored adhesive with PVC pipes will help you to remember to connect them up.)

Piping Diameter for Grouped Drain Pipes

- Select piping diameter from the below table in accordance with the amount of condensation drained by all units with a common drain pipe.
- Consider 2 l/hr of drainage for every 1 HP. For example, drainage from 3 units running at 2 HP and 2 units running at 3 HP is calculated as follows.
 $2 \text{ (l/hr)} \times 2 \text{ (HP)} \times 3 \text{ (units)} + \{ 2 \text{ (l/hr)} \times 3 \text{ (HP)} \times 2 \text{ (units)} = 24 \text{ l/hr}$

1. Relationship between horizontal pipe diameter and allowable drainage (for extended ventilation system)

JIS nominal	Vinyl chloride pipe diameter (mm)	Allowable flow rate (l/hr)		Remarks
		Piping gradient 1:50	Piping gradient 1:100	
VP20	20	39	27	(Reference value) Cannot be used in grouped piping.
VP25	25	70	50	
VP30	31	125	88	Can be used in grouped piping.
VP40	40	247	175	
VP50	51	473	334	

Notes:

- Calculations have been made with water area inside the pipe as 10%.
- Allowable flow rate figures below the decimal have been discarded.
- Use VP30 or larger pipe after the convergence point.

2. Relationship between riser diameter and allowable drainage (for extended ventilation system)

JIS nominal	Vinyl chloride pipe diameter (mm)	Allowable flow rate (l/hr)	Remarks
VP20	20	220	(Reference value) Cannot be used in grouped piping.
VP25	25	410	
VP30	31	730	Can be used in grouped piping.
VP40	40	1440	
VP50	51	2760	
VP65	67	5710	
VP75	77	8280	

Notes:

- Allowed flow rate figures below the decimal have been discarded.
- Use VP30 or larger pipe in risers.
- Use the same drain pipe for the humidifier as the indoor unit.

3.2.9 Drain Piping for Each Model

FXYCP-2-way blow ceiling mounted cassette

1. Rig drain piping

- The diameter of the drain pipe should be greater than or equal to the diameter of the connecting pipe (vinyl tube; pipe size: 25mm; outer dimension: 32mm).
- Keep the drain pipe short and sloping downwards at a gradient of at least 1/100 to prevent air pockets from forming.
- If the drain hose cannot be sufficiently set on a slope, execute the drain raising piping.
- To keep the drain hose from sagging, space hanging wires every 1 to 1.5 m.

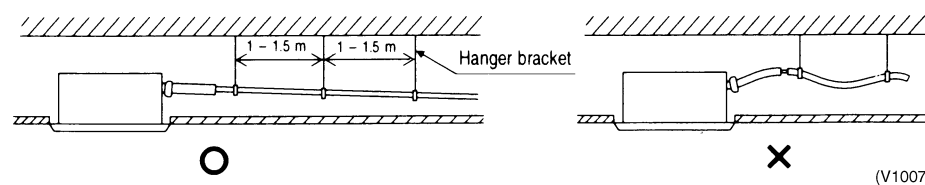

(V1007)

- Use the attached drain hose and clamp metal. Insert the drain hose into the drain socket, up to the white tape. Tighten the clamp until the screw head is less than 4 mm from the hose.
- Wrap the attached sealing pad over the clamp and drain hose to insulate.
- Insulate the drain hose inside the building.

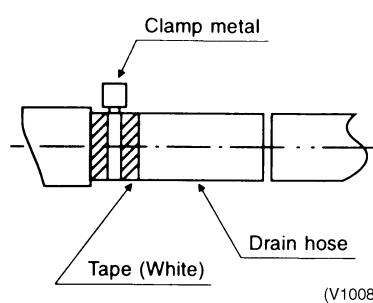

(V1008)

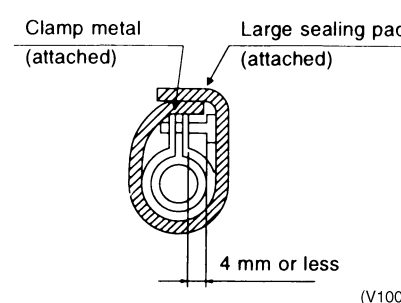

(V1009)

(PRECAUTIONS FOR DRAIN RAISING PIPING)

- Install the drain raising pipes at a height of less than 310 mm.
- Install the drain raising pipes at a right angle to the indoor unit and no more than 300 mm from the unit.

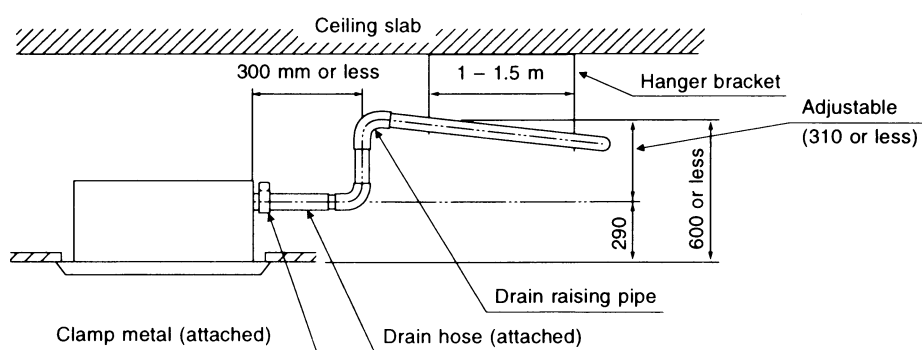

(V1010)

- If converging multiple drain pipes, install according to the procedure shown below.

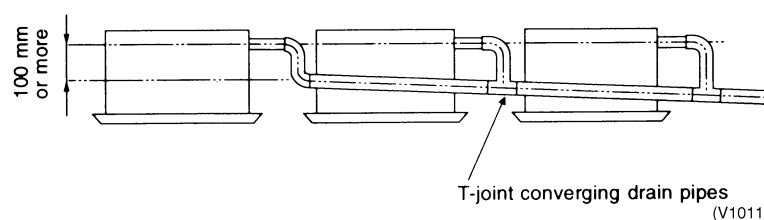

(V1011)

Select converging drain pipes whose gauge is suitable for the operating capacity of the unit.

2. After piping work is finished, check drainage flows smoothly.
 - Open the water inlet lid, add approximately 2500 cc of water gradually and check drainage flow.

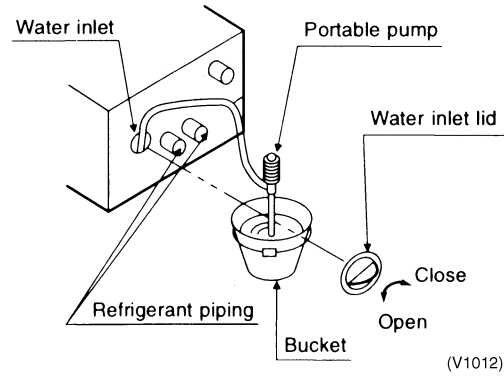

WHEN ELECTRIC WIRING WORK IS FINISHED

- Check drainage flow during COOL running, explained under "TEST OPERATION"

WHEN ELECTRIC WIRING WORK IS NOT FINISHED

- Remove the electric parts box lid, connect a power supply and remote control to the terminals. Next, press the inspection/test operation button "TEST" on the remote control. The unit will engage the test operation mode. Press the operation mode selector button "FAN OPERATION" until selecting FAN OPERATION. Then, press the ON/OFF button "ON/OFF". The indoor unit fan and drain pump will start up. Check that the water has drained from the unit. Press "TEST" to go back to the first mode.
- You can check whether drainage is satisfactory or not by removing the access opening lid and checking the water level of the drain pan through the access opening.
- **Be careful when doing so because the fan is turning at the same time.**

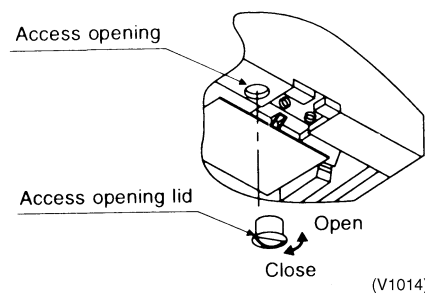
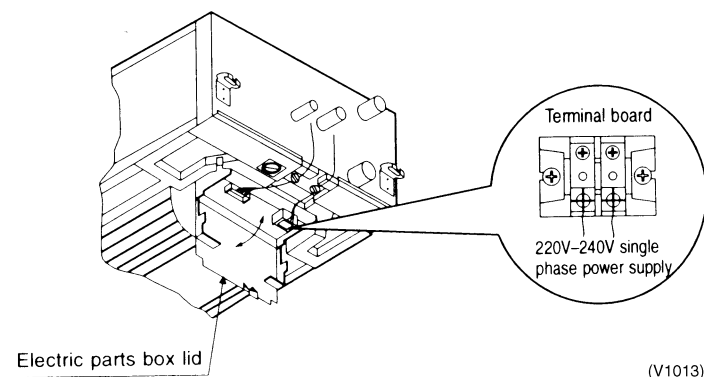

FXYFP-4-way blow ceiling mounted cassette

1. Rig drain piping
 - The diameter of the drain pipe should be greater than or equal to the diameter of the connecting pipe (vinyl tube; pipe size: 25mm; outer dimension: 32mm).
 - Keep the drain pipe short and sloping downwards at a gradient of at least 1/100 to prevent air pockets from forming.
 - If the drain hose cannot be sufficiently set on a slope, execute the drain raising piping.

- To keep the drain hose from sagging, space hanging wires every 1 to 1.5 m.

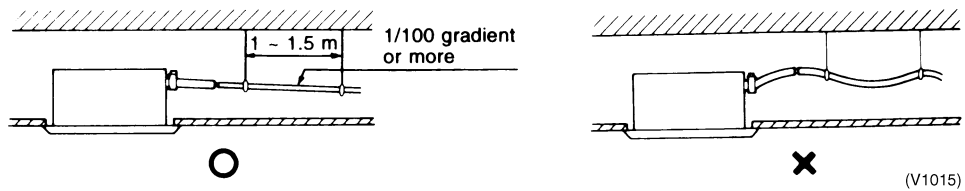

- Use the attached drain hose ① and clamp metal ②.
Insert the drain hose into the drain socket, up to the white tape. Tighten the clamp until the screw head is less than 4 mm from the hose.
- Wrap the attached sealing pad over the clamp and drain hose to insulate.
- Insulate the drain hose inside the building.

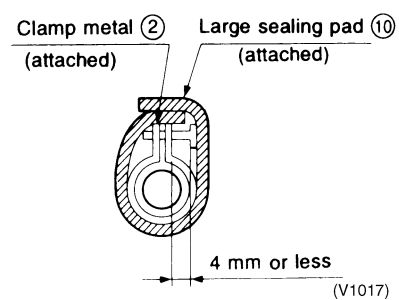
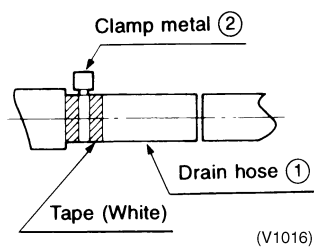

(PRECAUTIONS FOR DRAIN RAISING PIPING)

- Install the drain raising pipes at a height of less than 530 mm.
- Install the drain raising pipes at a right angle to the indoor unit and no more than 300 mm from the unit.

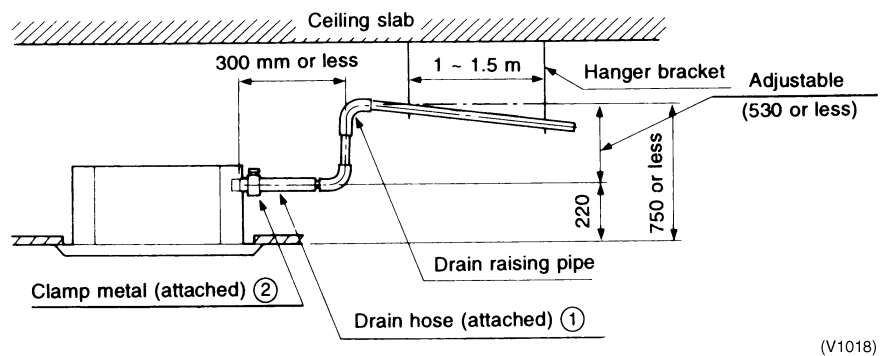

- i Note:**
- The incline of attached drain hose ① should be 75 mm or less so that the drain socket does not have to stand additional force.

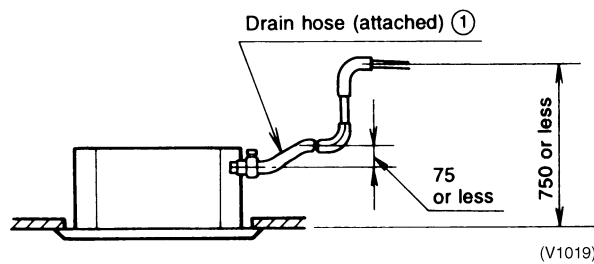

- If converging multiple drain pipes, install according to the procedure shown below.

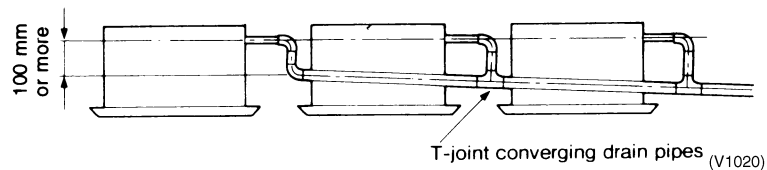

Select converging drain pipes whose gauge is suitable for the operating capacity of the unit.





2. After piping work is finished, check drainage flows smoothly.
 - Open the water inlet lid, add approximately 600 cc of water slowly and check drainage flow.

WHEN ELECTRIC WIRING WORK IS FINISHED

Check drainage flow during COOL running, explained under "TEST OPERATION".

WHEN ELECTRIC WIRING WORK IS NOT FINISHED

Remove the electric parts box lid, connect a power supply and remote control to the terminals.

Next, press the inspection/test operation button "  " on the remote control. The unit will engage the test operation mode. Press the operation mode selector button "  " until selecting FAN OPERATION "  ". Then, press the ON/OFF button "  ". The indoor unit fan and drain pump will start up. Check that the water has drained from the unit. Press "  " to go back to the first mode.

- Note that the fan also starts rotating.

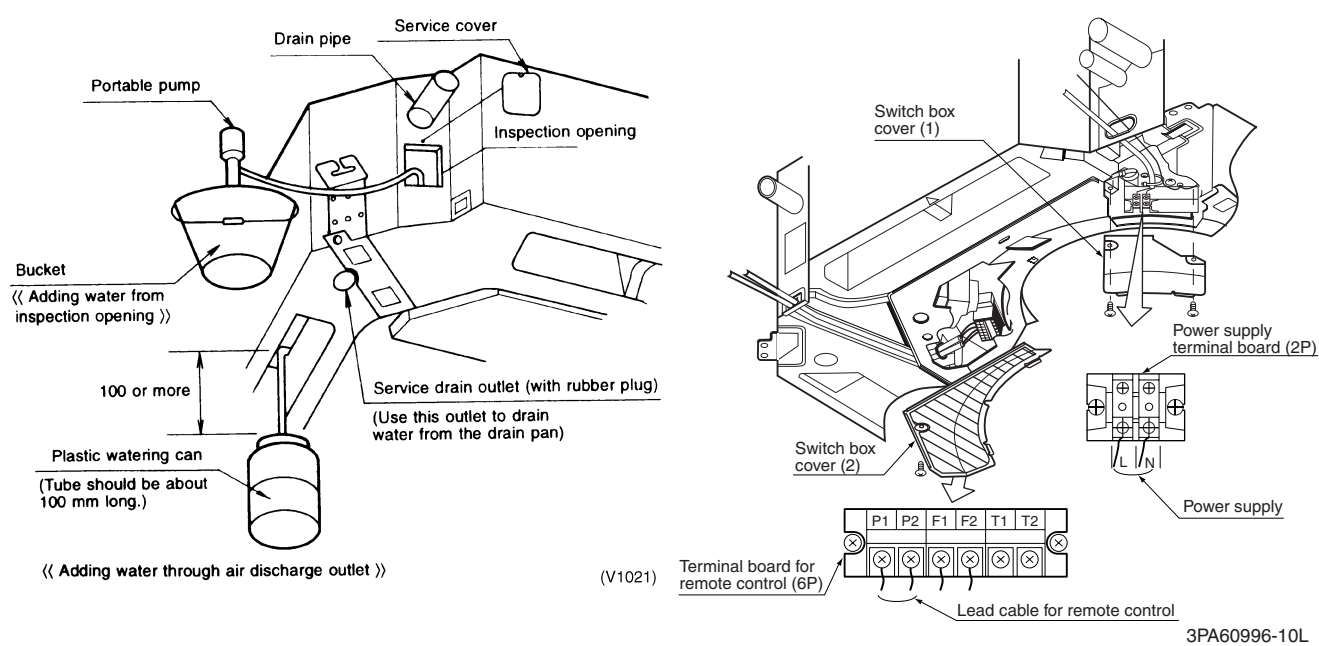

[Method of adding water]

FXYPK-ceiling mounted corner cassette

1. Install the drain pipes.
 - Keep piping as short as possible and slope it downwards so that air may not remain trapped inside the pipe.

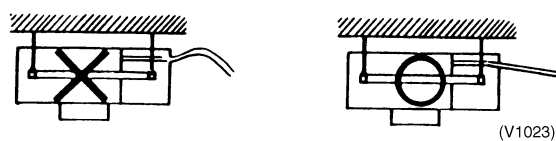

- Keep pipe size equal to or greater than that of the connecting pipe (Vinyl pipe of 25 mm nominal diam. and 32 mm outer diam.).
- Use the attached drain hose and clamp. Tighten the clamp firmly.
- Insulate the clamp with the attached sealing pad.

- Insulate the drain hose inside the building.

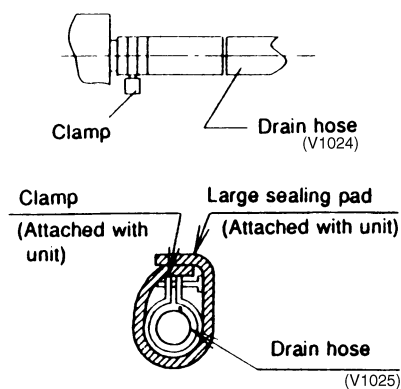

- If the drain hose cannot be sufficiently set on a slope, fit the hose with drain raising piping as shown in the drawing.
Be sur to use the attached drain hose, drain raising pipe, clamp and drain pipe insulation
- Secure a downward gradient of 1/100 or more for the drain pipe. To accomplish this, mount supporting brackets at an interval of 1 - 1.5 m.

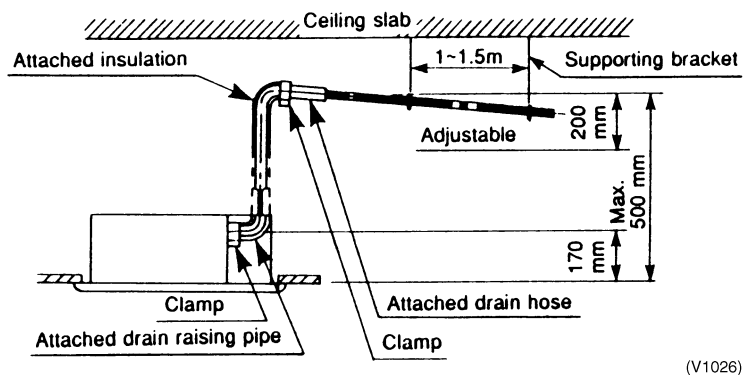

- Use the following outline if laying central drain piping.

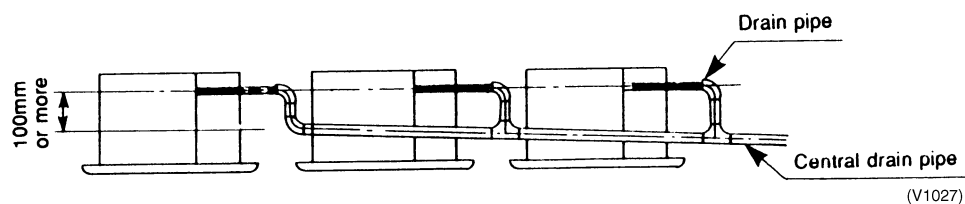

(Drain raising pipe laying procedure)

- (1) Connect the drain raising pipe and drain hose and fasten with a clamp.
- (2) Mount the drain pipe insulation and wrap with vinyl tape.
- (3) After completing steps (1) and (2), attach the drain raising pipe to the drain pipe connection port of the indoor unit and fasten with a clamp. (Do not connect any other pipes between the drain raising pipe and the indoor unit.)

- Adjust the drain raising height by turning the drain raising pipe as shown in the figure.

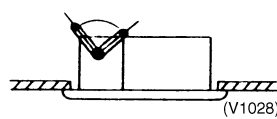

2. After piping, check to make sure draining flows smoothly.

If construction work for interconnecting piping is complete:

Using a plastic container for water filling, etc., gradually inject about 1,000 cc of water into the drain pan through the inspection hatch.

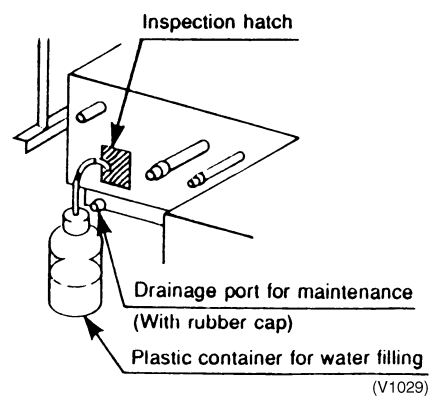

i Note: To drain water from the drain pan, use the drainage port for maintenance.

WHEN ELECTRIC WIRING WORK IS FINISHED

Check drainage flow during COOL running, explained under "TEST OPERATION".

WHEN ELECTRIC WIRING WORK IS NOT FINISHED

Remove the electric parts box lid, connect a power supply and remote control to the terminals.

Next, press the inspection/test operation button "TEST" on the remote control. The unit will engage the test operation mode. Press the operation mode selector button " " until selecting FAN OPERATION " ". Then, press the ON/OFF button " ". The indoor unit fan and drain pump will start up. Check that the water has drained from the unit. Press "TEST" to go back to the first mode.

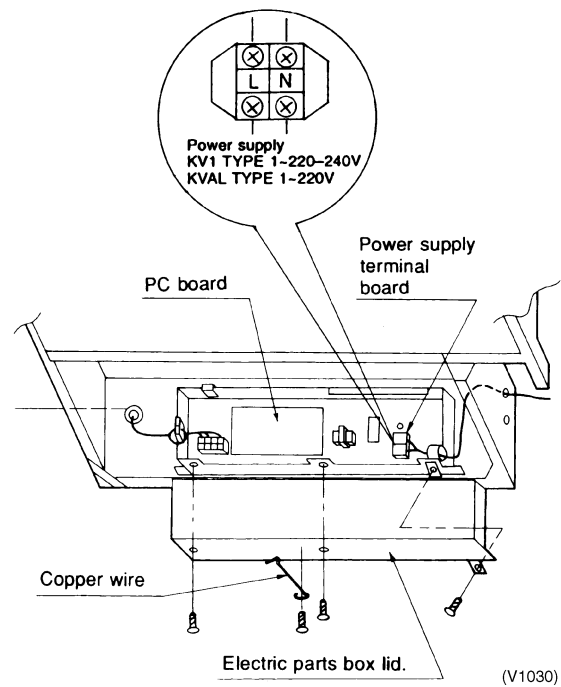

FXYSP-Concealed ceiling unit

1. Install the drain pipes.
 - Keep piping as short as possible and slope it downwards so that air may not remained trapped inside the pipe.

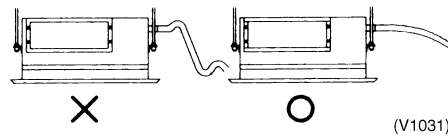

- Keep pie size equal to or greater than that of the connecting pipe (Vinyl pipe of 25 mm nominal diam. and 32 mm outer diam.).
- Use the attached drain hose and clamp. Tighten the clamp firmly.
- Insulate the clamp with the attached sealing pad.
- Insulate the drain hose inside the building.
- If the drain hose cannot be sufficiently set on a slope, fit the hose with drain raising piping as shown in the drawing.

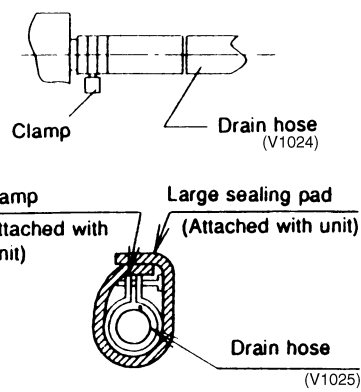

<HOW TO INSTALL PIPING>

- (1) Connect the drain hose to the drain raising pipes, and insulate them.
- (2) Connect the drain hose to the drain outlet on the indoor unit, and tighten it with the clamp.
- (3) Insulate both metal clamp and drain hose with the attached sealing pad.

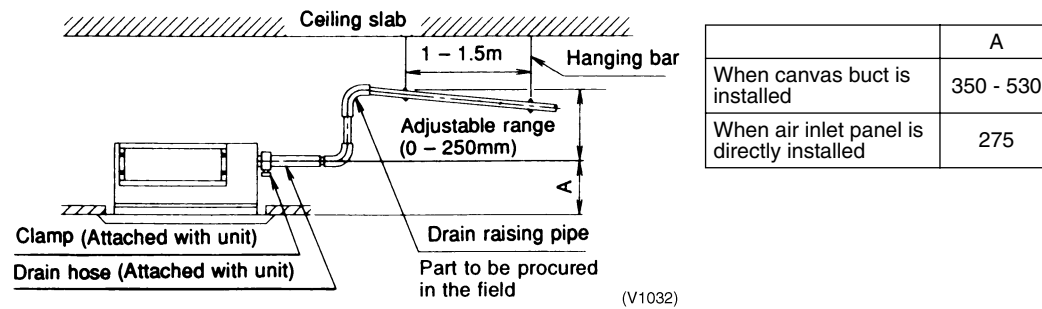

- To ensure a down ward slope of 1:100, install hanging bars every 1 to 1.5 m.
- If unifying multiple drain pipes, install pipes shown right.

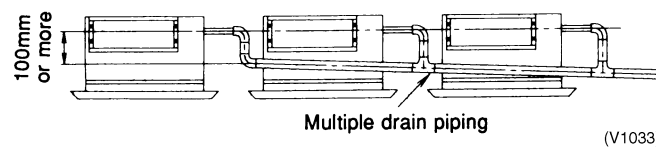

2. After piping, check to make sure draining flows smoothly.
- Open the water inlet lid, add approximately 1000 cc of water gradually and check drainage flow.

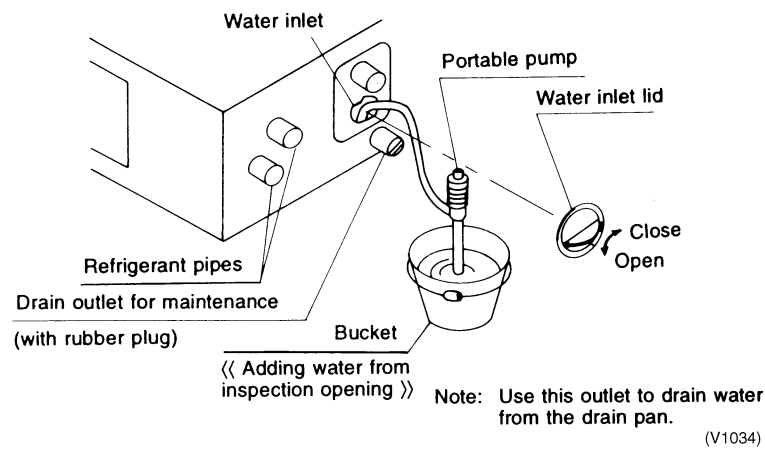





WHEN ELECTRIC WIRING WORK IS FINISHED

Check drainage flow during COOL running, explained under "TEST OPERATION".

WHEN ELECTRIC WIRING WORK IS NOT FINISHED

Remove the electric parts box lid, connect a power supply and remote control to the terminals.

Next, press the inspection/test operation button "  " on the remote control. The unit will engage the test operation mode. Press the operation mode selector button "  " until selecting FAN OPERATION "  ". Then, press the ON/OFF button "  ". The indoor unit fan and drain pump will start up. Check that the water has drained from the unit. Press "  " to go back to the first mode.

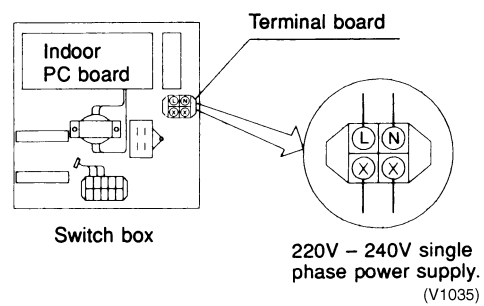

3.2.10 Electrical Work

Control Wiring

1. Compatible types of wire

Wiring Specifications

Wiring Type	Shield Wire (2 wire) (See NOTE 1, 2)
Size	0.75~1.25 mm ²



Notes:

1. Sheathed wire may be used for transmission wirings, but they do not comply with EMI (Electromagnetic Interference) (EN55014). When using sheathed wire, EMI must conform to Japanese standards stipulated in the Electric Appliance Regulatory Act. (If using a sheathed wire, the grounding shown in the figure on the left is unnecessary.)
2. For FXYAP indoor unit, use sheathed wire.

2. Problems arising from the use of unsuitable cable

a) When cable less than 0.75 mm² is used

Where the control wiring is particularly long the transmission signals may, for example, become unstable and the terminal relay cease to function. (Reduced voltage) The control system may become unduly subject to noise interference.

b) When cable more than 1.25 mm² is used

When wiring indoor units together, the terminal block will not be able to accommodate 2 cables simultaneously if the cables are larger than 1.25 mm².

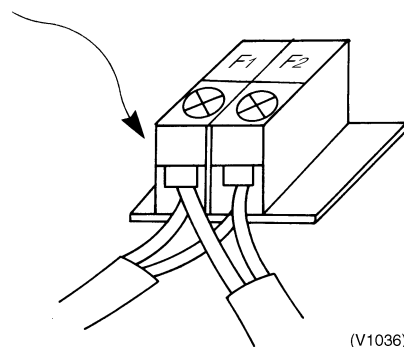

(V1036)

c) For multi-core cable

The greater play between wires, the more the transmitted wave is distorted and transmission destabilized.

d) In the case of a remote control with a three way selector for cooling, heating and ventilation, twin core cable should be used when the ventilation mode is not required and three core cable should be used when three way selection is required.

e) Since there is a considerable risk of mixing high (220 to 240V) and low voltages in the case of, for example, a PCB for remote control, multiple core cable must not be used. (Internal wiring regulations and dielectric strengths of cables are relevant here.)

[Example of incorrect method]

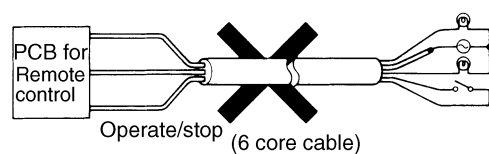

Operate/stop (6 core cable)

[Example of correct method]

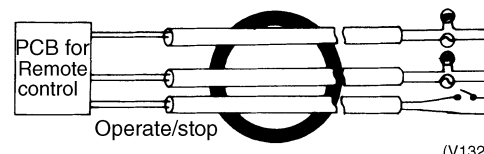

Operate/stop

(V1323)

f) Other important points

1. The refrigerant circuit and the indoor/outdoor connecting cables must correspond exactly.
2. A suitable gap must be left between the control cables and the power supply cables where these are laid alongside each other. (See "Separation of control and power supply cables" on page 48)

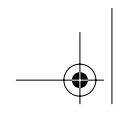
**Power Supply
(Cabling of Main
Power Supply)****1. Choosing a circuit breaker**

The power supply work must conform to local regulations. In Japan, the relevant regulations are the MITI ordinance determining technical standards for electrical equipment, and the Internal Wiring Provisions.

a) The indoor unit circuit breakers

- In accordance with the provisions for internal wiring (JEAC8001-1986), power may be supplied by means of crossover lines between the indoor units in a single system branch circuit.

Branch circuit facility (Internal wiring provisions 305-2)

The motors must be set up with a dedicated branch circuit for each unit. However, where they correspond to any of the following situations, this limitation does not apply.

① When used in a 15A branch circuit of a 20A circuit breaker branch circuit

Note: It is recommended that the total rated capacity of the motors set up in a 15A branch circuit or a 20A circuit breaker branch circuit should be no more than 2.2kW.

Example of 15A branch circuit or 20A circuit breaker branch circuit

Branch two-way switch
Branch overcurrent circuit breaker (Rated current: 15A or less. In case of circuit breaker: 20A or less)

Manual switch Manual switch

M M

(V1038)

When using high static pressure indoor units the fan motors must have a large capacity. Single phase 220~240V branch circuits are therefore required for each indoor unit.

Example: Up to 10 × 2.5HP indoor units or 5 × 5HP indoor units can be wired together.

b) The outdoor unit circuit breaker

- A separate circuit breaker must be fitted for each unit.
- The motors incorporated into air conditioning system compressors are treated as special motors under the internal wiring provisions. The values which apply to normal motors are thus somewhat variance with those which apply to such compressor motors. You are recommended to adhere strictly to the procedures laid down in the technical materials included in, for example, the system design manuals.

Calculation of load (Refer to local regulation.)

With respect to the calculation of load for motors with special applications such as elevator, air conditioner and refrigerator motors, not only must the rated current be shown on the name plate of the said motor or piece of apparatus but it must also included all special characteristics or applications.



Note: The rated current for package air conditioners which use special purpose built-in compressor motors in their compressors in 1.2 times the operating current shown on the name plate.

2. Cable size

The thickness of the cables in the circuits (branch circuits) providing the main power supply to each item of apparatus must satisfy the following conditions:

1. To have a current tolerance of 40% or more of the rated current of the overcurrent circuit breaker (wiring circuit breaker, etc.).
2. To have a current tolerance of 125% or more of the rated current in cases where the rated current of the apparatus is 50A or less.
3. To have a current tolerance of 110% or more of the rated current in cases where the rated current of the apparatus is more than 50A.
4. To satisfy voltage drop standards.

3. Separation of control and power supply cables

- If control and power cables are run alongside each other then there is a strong likelihood of operational faults developing due to interference in the signal wiring caused by electrostatic and electromagnetic coupling.

The table below indicates our recommendations as to the appropriate spacing of control and power cables **where these are to be run side by side**.

	Current capacity of power cable	Spacing (d)
100V or more	10A or less	300mm
	50A	500mm
	100A	1000mm
	100A or more	1500mm

**Notes:**

1. The figures are based on an assumed length of parallel cabling up to 100m. For lengths in excess of 100m the figures will have to be recalculated in direct proportion to the additional length of cable involved.
2. If the power supply waveform continues to exhibit some distortion the recommended spacing in the table should be increased.

If the cables are laid inside conduits then the following points must also be taken into account when grouping various cables together for introduction into the conduits.

1. Power cables (including power supply to the air conditioner) and signal cables must not be laid inside the same conduit. (Power cables and signal cables must each have their own individual conduits.)
2. In the same way, when grouping the cables, power and signal cables should not be bunched together.

■ **Important points**

1. Earthing

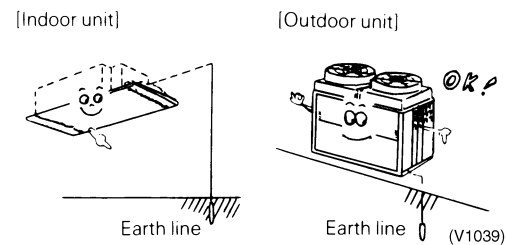

- Have the indoor and outdoor units both been earthed?

* If the apparatus is not properly earthed then there is always a risk of electric shocks. The earthing of the apparatus must be carried out by a qualified person.

3.2.11 Duct Work (Indoor)

■ Operational steps

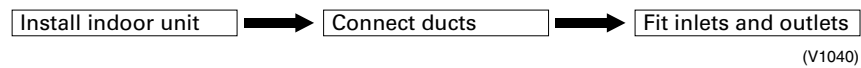

(V1040)

Taking Account of Noise and Vibration

- a) Canvas joints must be used between the main unit and the air suction and discharge ducts. These fittings are designed to inhibit secondary noise resulting from the transmission of vibrations and operating noise from the main unit to the ducts or to the rest of the building.

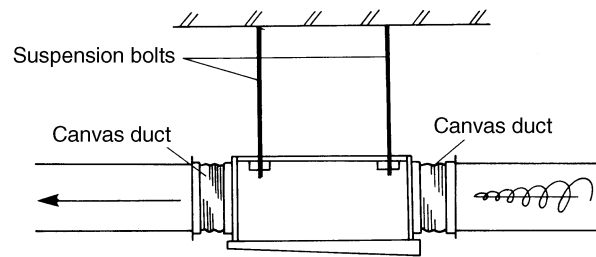

(V1041)

- b) The speed of the airflow should be taken into account when choosing air suction and distribution grills in order to keep wind noise to minimum.

■ Important points

1. The air discharge duct must be thermally insulated.
2. The canvas duct on the inlet side must be set in a metal framework.
3. The air suction and distribution grills should be positioned to take into account the possibility of short circuits.
4. Static pressure should be checked to ensure that the airflow is within the specified range.
5. The air filter must be easily detachable.

3.2.12 Installation of Outdoor Unit

Operational steps

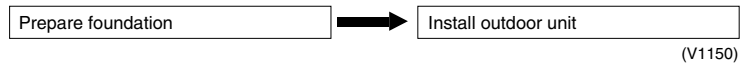

Foundation of Units

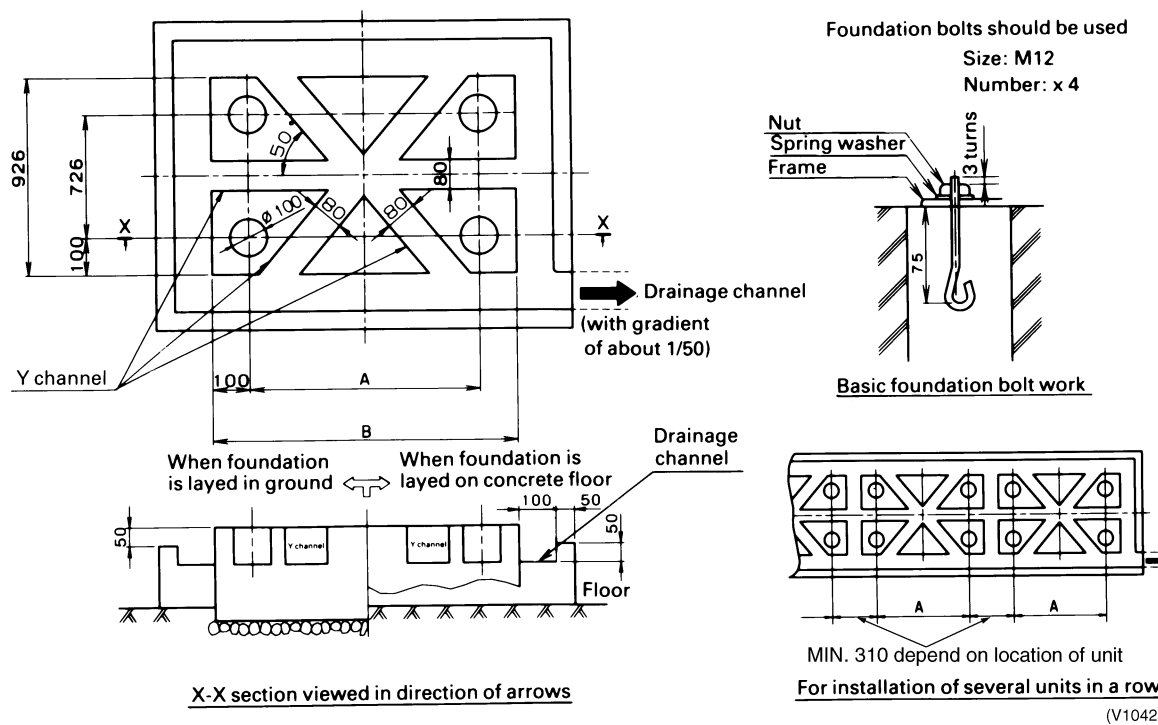

Model	A	B
RXYP8 RXYP10 RXEP8 RXEP10	1000	1200
RXYP16 RXYP20	2290	2490



- Notes:**
- Standard concrete mix: 1 cement / 2 sand / 4 gravel with 10 reinforcing rods (approx. 300mm intervals).
 - Mortar should be used to level the surface. The edge of the concrete surface should be bevelled.
 - When setting the foundation on a concrete floor macadam is not required but the surface of the concrete should be broken up to make it uneven.
 - A drainage channel should be made around the foundation to cater for waste water around the machinery.
 - When installing a unit on the roof be sure to check the strength of the roof and pay special attention to waterproofing requirements.
 - If the unit is to be installed on a frame, install the waterproofing board within a distance of 150mm under the unit in order to prevent infiltration of water coming from under the unit.

Bolt pitch

RXYP8/10K, RXEP8/10K

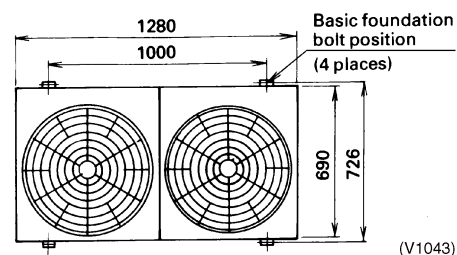

RXYP16/20K

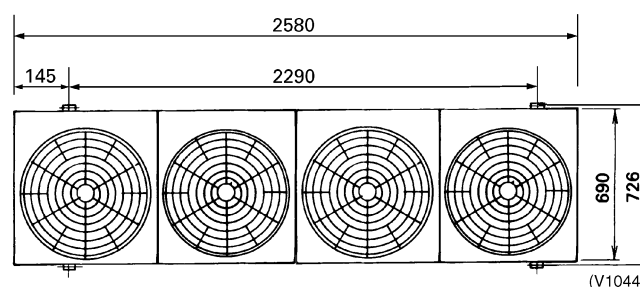

■ Caution in installation

1. Execute the installation work by checking the foundation strength and levelness to avoid any occurrence of vibration and noise.

Fix the unit tightly with foundation bolts. (Prepare 4 sets of M12 foundation bolts with proper nuts and washers.)

The proper length of the foundation bolts from the surface of the base is 20mm.

The foundation must support the unit in the range above the shaped portion in the figure 1.

2. Remove the fitting (yellow color) for loading as shown in the figure 2.

Tighten the installation bolt of compressor firmly again.

2 fittings are attached to the front side of a single compressor.



Caution

Install the unit securely in case of earthquake an typhoon, cyclone, hurricane or other strong wind. The unit may topple or cause another accident if improperly set up.

Unpacking and Placing the Unit

1. Remove the wooden crate from the unit.
2. Remove the four screws fixing the unit to the pallet.
3. The unit must be installed on a solid longitudinal foundation (steelbeam frame or concrete) as indicated in figure 1.

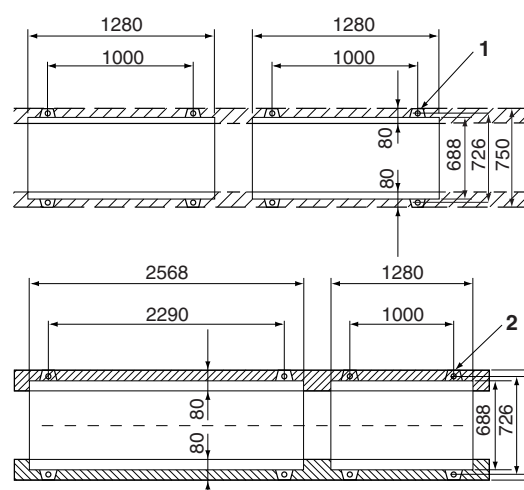

Fig. 1
(V0853)

1. Fundamental bolt position ($\phi 15$ holes ... 8 places)

Bad Example

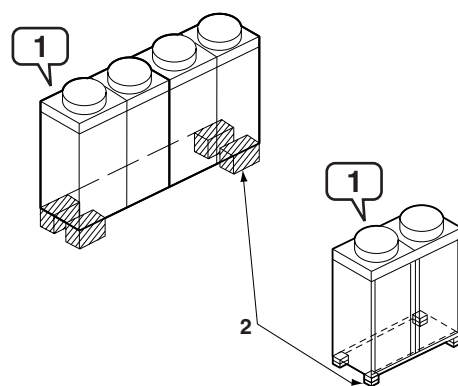

Fig. 2
(V0852)

1. ✘ No!
2. Do not use stands to support the corners.



Note: Maximum height of the foundation is 150mm.

4. Lift the unit from the pallet and place it on its installation position.
5. Fasten the unit in place using four anchor bolts M12.
6. Remove the upper and lower service plate.
7. When closing the service panels take care that the tightening torque does not exceed 4.1 Nm.
8. Remove the yellow shipping stays from the compressor support as shown in the figure (2 stays per single compressor). Tighten the installation bolts firmly again afterwards.

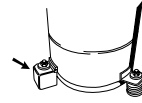
Fig. 3
(V0898)

Service Space

It is extremely important that enough space is left when installing the equipment to allow routine servicing and maintenance to be carried out without undue hindrance. It is particularly important to bear in mind the work which will be required if the compressor needs to be replaced. (The layout of the pipework can sometimes cause considerable difficulties if the compressor needs to be changed.)

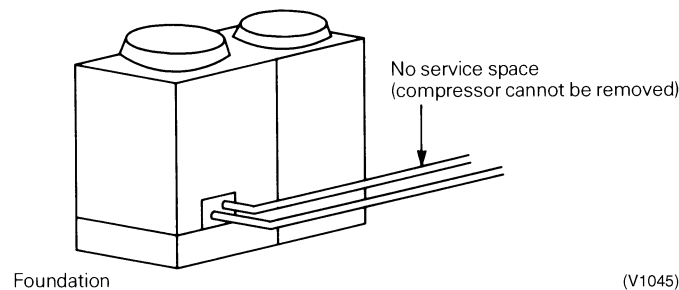

Prevention of Short Circuits

The unit must be installed in a well ventilated area, otherwise short circuiting will occur. Special care should be taken in situations such as that illustrated in the diagram below since additional fittings such as air discharge ducts may also be required. (Attention should be paid to the duct's resistance)

Conditions for installation under the eaves

- When $L \geq 1\text{m}$ then N must be $\geq M$.
- When $L < 1\text{m}$ then K must be $\geq M$.

Where K is the required dimension for a single unit installation.

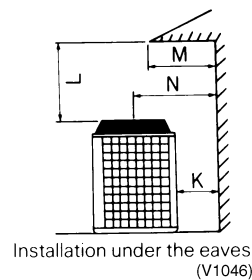

Conditions for installation where there is a horizontal obstruction above the unit

- When $L \geq 3\text{m}$ then no special action is required.
- When $L < 3\text{m}$ then an air discharge duct with resistance within $3\text{mmH}_2\text{O}$ is required. Where K measures a little more than the required K dimension for a single unit installation.

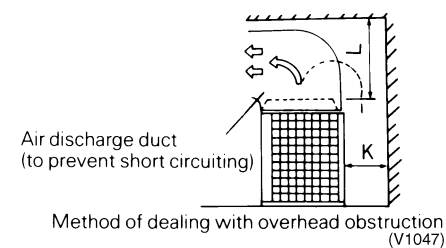

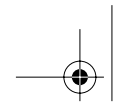

Installation

SiE33-003

Techniques for Prevention of Snow Accumulation in Areas of High Snowfall

1. Snow must be prevented from accumulating around the outdoor unit's air inlet and air discharge outlet and one possible answer would be to fit a snow hood.

[Points relating to design of snow hood]

- In order to ensure the required outdoor unit airflow the duct resistance must be less than the permissible external static pressure of 3 mmH₂O.
- The structure must be robust enough to withstand the weight snow building up on it and strong winds or typhoons.
- The construction of the unit should be such as to avoid short circuiting between suction air and discharge air.

A snow hood is available from Daikin as an optional accessories so please make use of it where necessary.

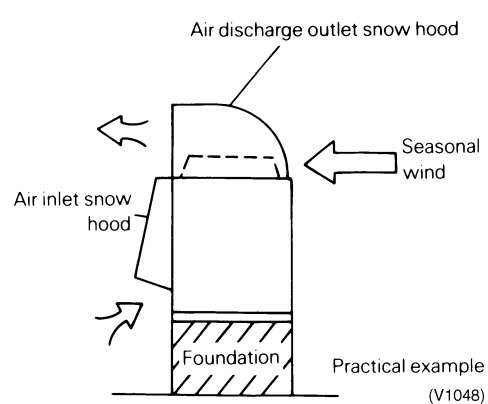

2. The unit should be oriented in such a way as to prevent the air heat exchanger from facing into driving snow.
3. The outdoor unit should be set at a higher level in relation to the surface on which it is mounted than the anticipated depth of snow accumulation in order to prevent it from being buried.
4. Measures to combat lightning and burying by drifting snow.
The proposed installation spot should be thoroughly investigated and on no account should the unit be placed beneath eaves or trees where snow is likely to drift.

When units are located on different floors

Special care must be taken with respect to short circuits when units are installed on each floors.

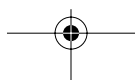

Selection of Location

When placing several units in close proximity to each other some thought should be given to the possibility of short circuiting and also to the provision of adequate space for servicing. (For more detailed information please refer to the system design materials.)

This unit, both indoor and outdoor, is suitable for installation in a commercial and light industrial environment. If installed as a household appliance it could cause electromagnetic interference.

The VRV plus outdoor units should be installed in a location that meets the following requirements:

1. The foundation is strong enough to support the weight of the unit and the floor is flat to prevent vibration and noise generation.
2. The space around the unit is adequate for servicing and the minimum space for air inlet and air outlet is available. (Refer to figure 1 and choose one of both possibilities.)

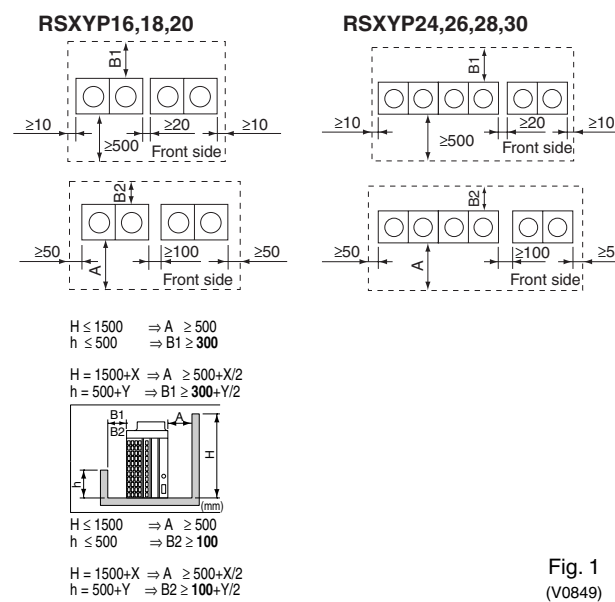

Fig. 1
(V0849)

3. There is no danger of fire due to leakage of inflammable gas.
4. Ensure that water cannot cause any damage to the location in case it drips out the unit (e.g. in case of a blocked drain pipe).
5. The piping length between the outdoor unit and the indoor unit may not exceed the allowable piping length. (See "Example of connection".)
6. Select the location of the unit in such a way that neither the discharged air nor the sound generated by the unit disturb anyone.
7. Make sure that the air inlet and outlet of the unit are not positioned towards the main wind direction. Frontal wind will disturb the operation of the unit. If necessary, use a windscreen to block the wind.



Caution

1. An inverter air conditioner may cause electronic noise generated from AM broadcasting. Examine where to install the main air conditioner and electric wires, keeping proper distances away from stereo equipment, personal computers, etc.

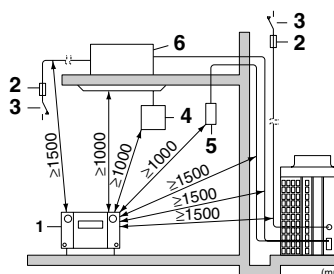

Fig. 2
(V0850)

1. Personal Computer or Radio
2. Fuse
3. Earth Leak Detector
4. Remote Control
5. Cool/Heat Selector
6. Indoor Unit

If the electric wave of AM broadcasting is particularly weak, keep distances of 3m or more and use conduit tubes for power and transmission lines.

2. In heavy snowfall areas, select an installation site where snow will not affect operation of the unit.
3. The refrigerant R-407C itself is nontoxic, nonflammable and is safe. If the refrigerant should leak however, its concentration may exceed the allowable limit depending on room size. Due to this it could be necessary to take measures against leakage. Refer to the chapter 'Caution for refrigerant leaks'.

4. Test Operation

4.1 Procedure and Outline

The operation sequence is the most important thing for test operation. Follow the following outline.

4.1.1 Check the Following Before Turning Power On

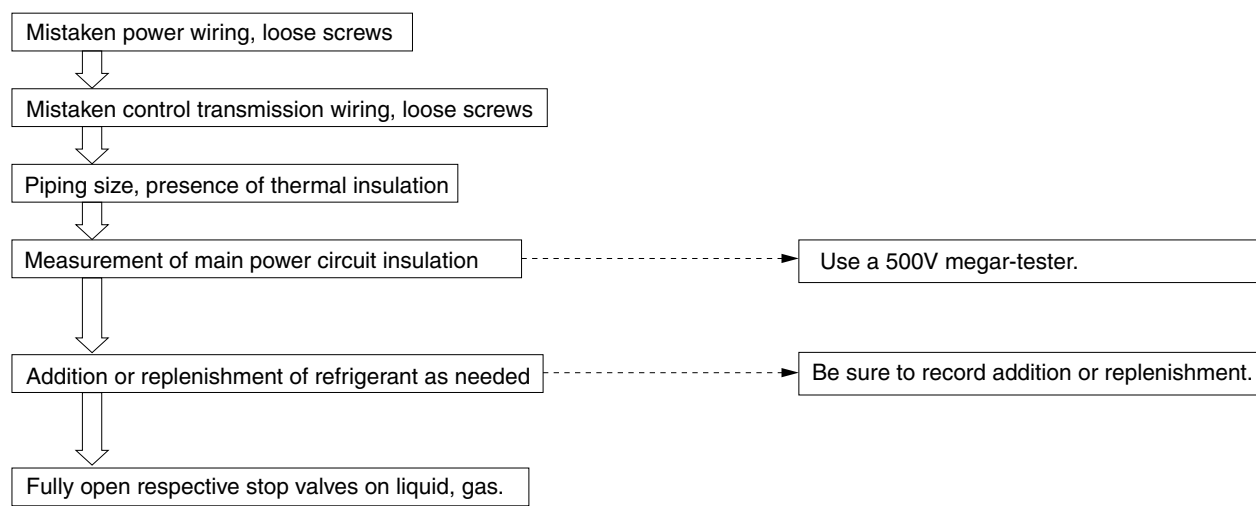

(V1324)

4.1.2 Turn Power On

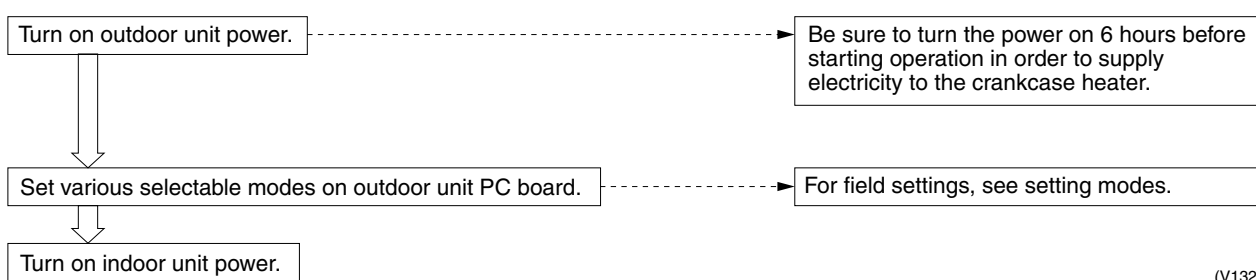

(V1325)



Refer to Setting Modes on P61

4.1.3 Check Operation

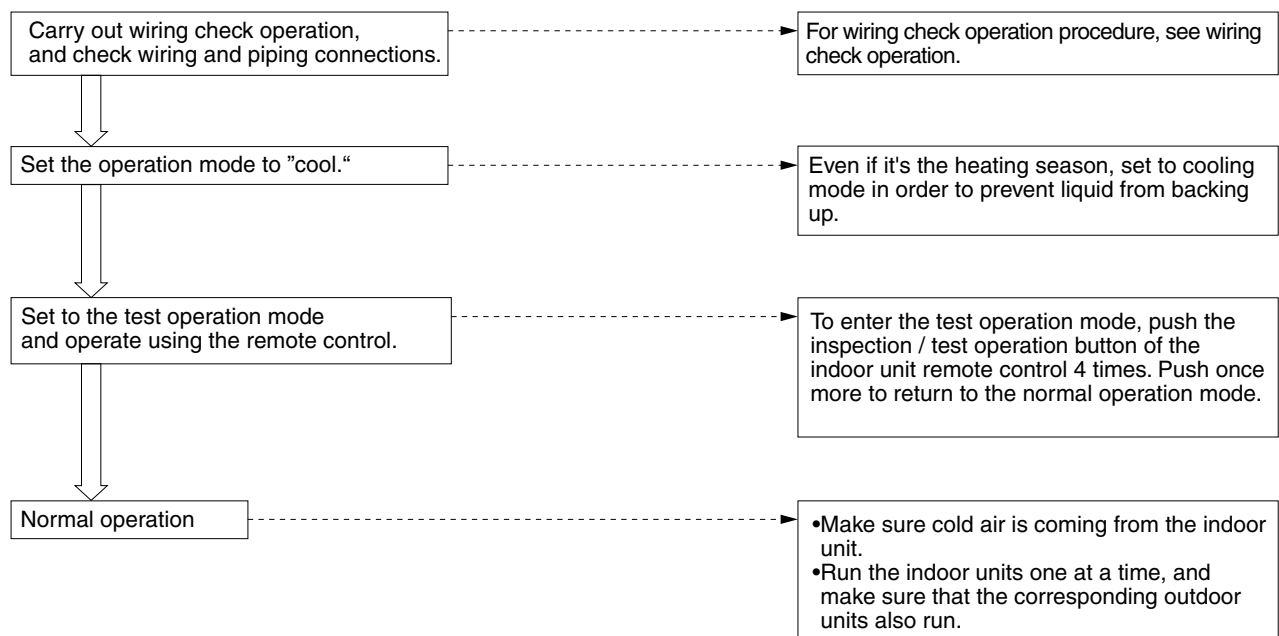

(V1326)



Refer to Wiring Check Operation on P76



Caution

When the 400 volt power supply is applied to "N" phase by mistake, replace Inverter P.C.B (A2P) and control transformer (T1R, T2R) in switch box together.

(V0847)

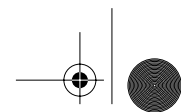

4.2 Operation When Power is Turned On

4.2.1 When Turning On Power for First Time

The unit cannot be run for up to 12 minutes to automatically set the master power and address (indoor-outdoor address, etc.).

- ◆ Outdoor unit ... Warning lamp (H2P) lights
Test lamp (H2P) blinks
Can also be set during operation described above.
- ◆ Indoor unit ... If ON button is pushed during operation described above, the "UH" malfunction indicator blinks. (Returns to normal when automatic setting is complete.)

4.2.2 When Turning On Power The Second Time and Subsequent

Tap the RESET button (BS5) on the outdoor unit PC board. Operation becomes possible after setting up for about 2 minutes. If you do not push the RESET button, the unit cannot be run for up to 10 minutes to automatically set master power.

- ◆ Outdoor unit ... Warning lamp (H2P) lights
Test lamp (H2P) blinks
Can also be set during operation described above.
- ◆ Indoor unit ... If ON button is pushed during operation described above, the operation lamp lights but the compressor does not operate. (Returns to normal when automatic setting is complete.)

4.2.3 When an Outdoor Unit or Indoor Unit Has Been Added, or Indoor / Outdoor Units PC Board Has Been Changed

Be sure to push and hold the wiring change button for 5 seconds or longer. If not, the addition cannot be recognized. In this case, the unit cannot be run for up to 12 minutes to automatically set the address (indoor-outdoor address, etc.).

- ◆ Outdoor unit ... Warning lamp (H2P) lights
Test lamp (H2P) goes off
Can also be set during operation described above.
- ◆ Indoor unit ... If ON button is pushed during operation described above, the "UH" or "U4" malfunction indicator blinks. (Returns to normal when automatic setting is complete.)



4.3 Outdoor Unit PC Board Ass'y

Outdoor Unit

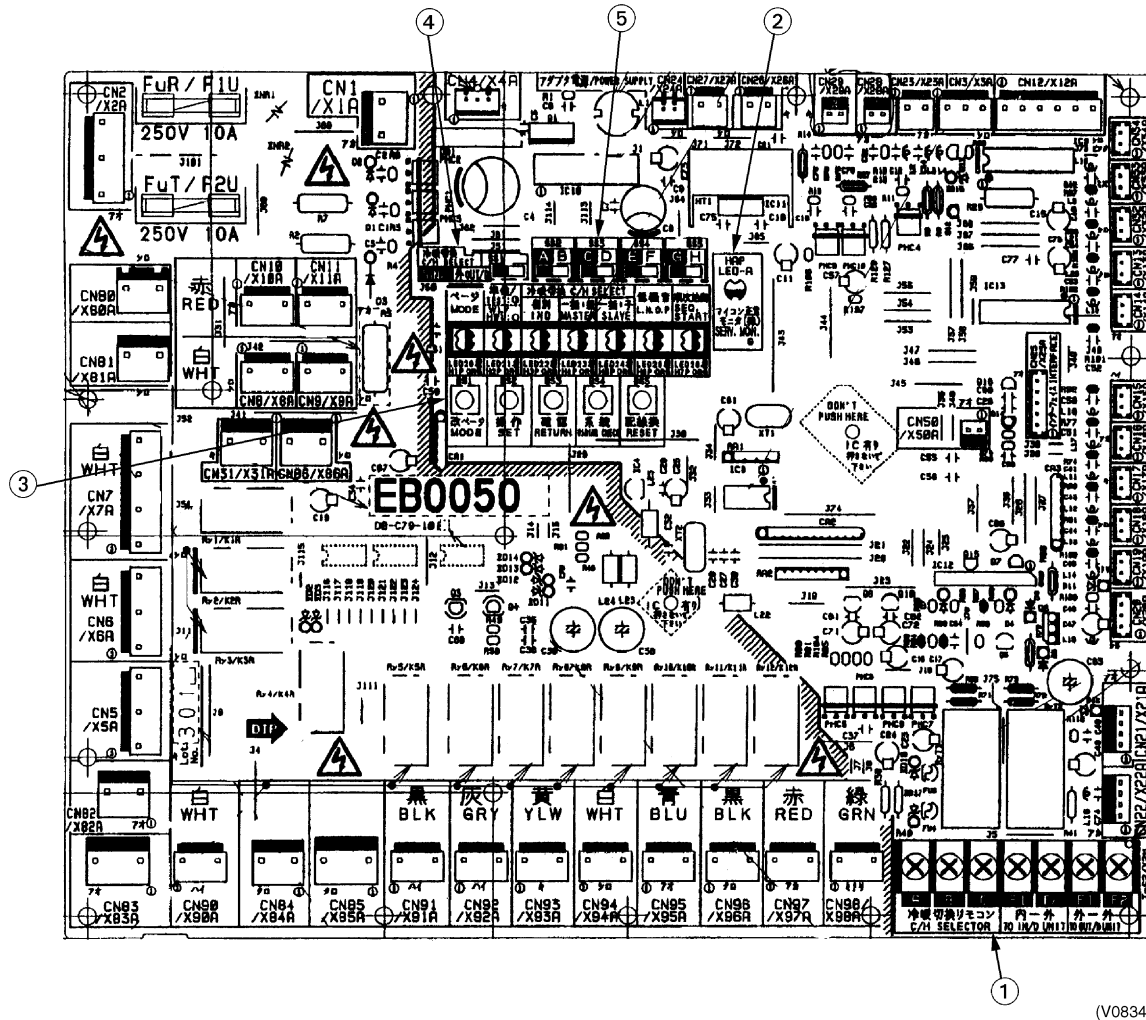

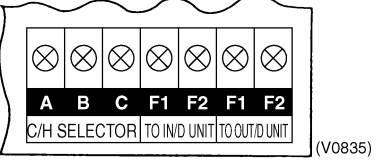
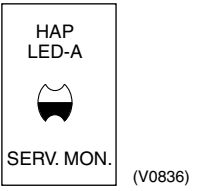
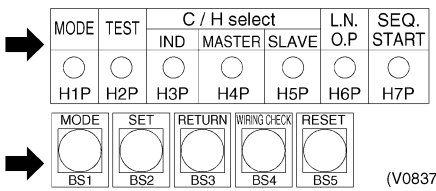
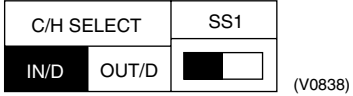
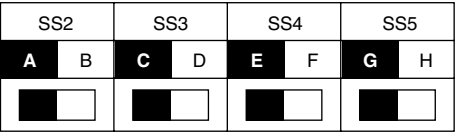
1	Transmission terminal Indoor unit, Cool/Heat selector Outdoor - Outdoor	 <p>(V0835)</p>
2	Service monitor LED (Green)	 <p>(V0836)</p>
3	Function setting mode switch and LED	<p>LED</p> <ul style="list-style-type: none"> ○ : ON ◐ : Flash ● : OFF <p>Push Button switch</p>  <p>(V0837)</p>
4	Function of setting between cooling and heating	 <p>(V0838)</p>
5	Outdoor unit Capacity setting switch	<p>Switches for capacity setting when the outdoor unit PC board is replaced to spare parts PC board.</p>  <p>(V0848)</p> <p>Refer table below.</p>

	SS2		SS3		SS4		SS5	
	A	B	C	D	E	F	G	H
RSXYP16KJ		■		■	■			■
RSXYP18KJ		■	■			■		■
RSXYP20KJ		■	■			■		■
RSXYP24KJ		■	■		■		■	
RSXYP26KJ		■	■		■		■	
RSXYP28KJ	■			■		■		■
RSXYP30KJ	■			■		■		■

Capacity setting table
↑
Position of dipswitch

i Note: Resetting of power supply switch is necessary after capacity setting.

4.4 Setting Modes

There are the following three setting modes.

◆ **Setting mode 1 (H1P off)**

Used to select the cool/heat setting, low-noise run and sequential start.

◆ **Setting mode 2 (H1P on)**

Used to modify the running status and to program addresses, etc. Usually used in servicing the system.

◆ **Monitor mode (H1P flashing)**

Used to check the programs made in the setting mode 2, the number of units being connected, and other entries.

Functions of Pushbutton Switches

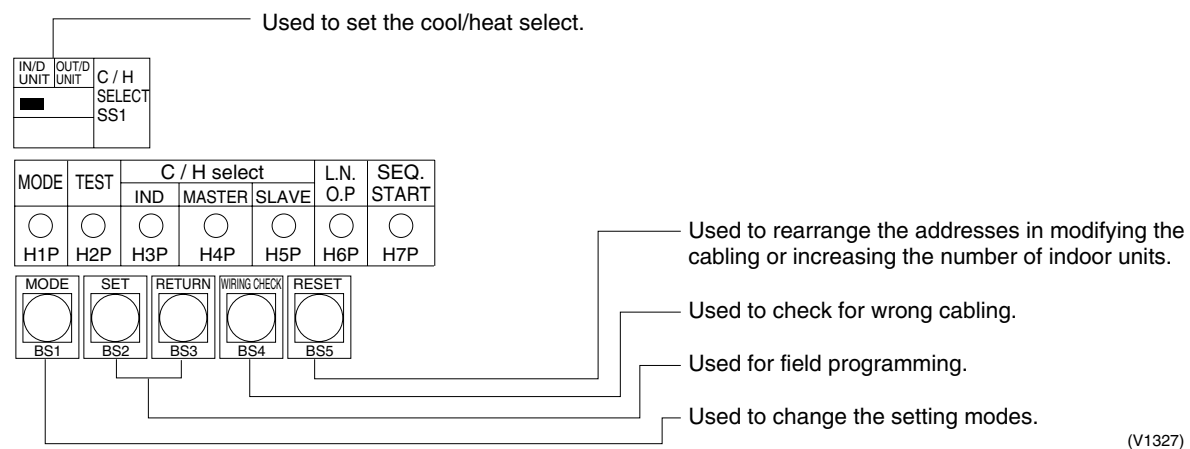

Mode Change

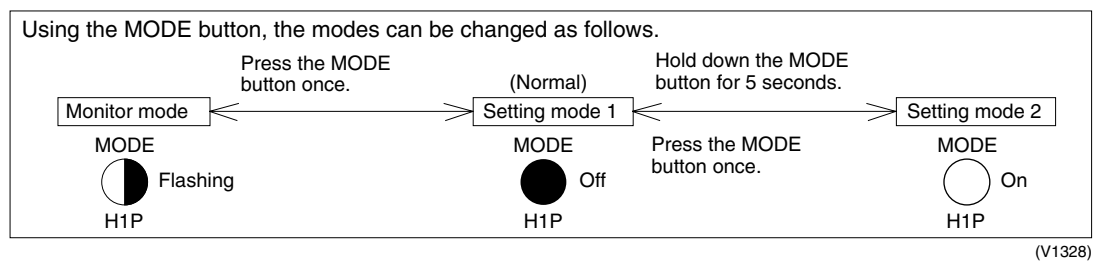

Mode Changing Procedure

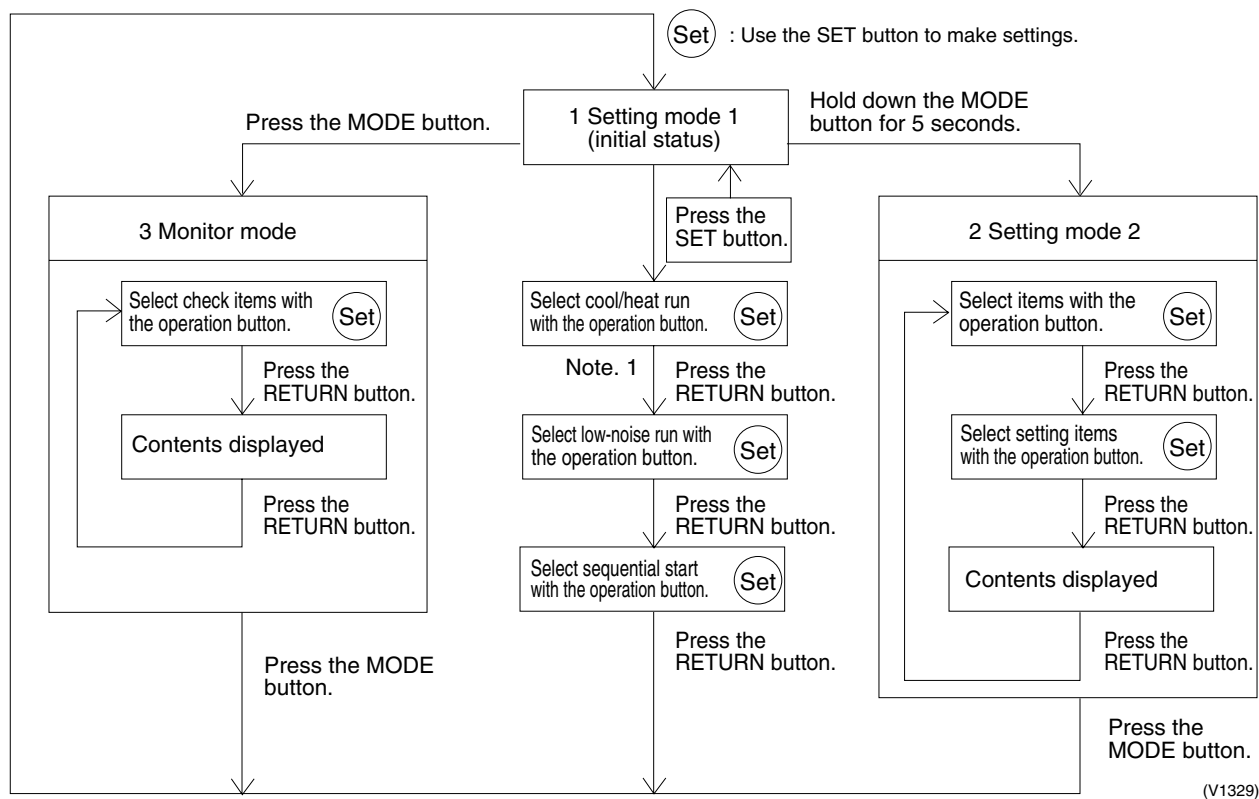

- i Note:**
1. If you become unsure of how to proceed, push the MODE button (BS1) and return to setting mode 1.
 2. Power reset is not necessary after setting of setting mode 1 (including C/H select SS1) and setting mode 2.

4.4.1 Setting Mode 1

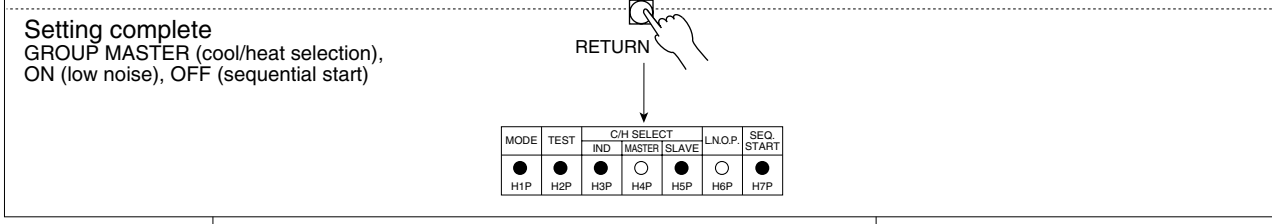
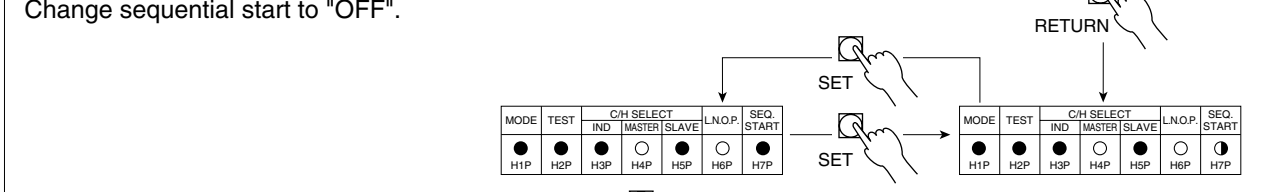
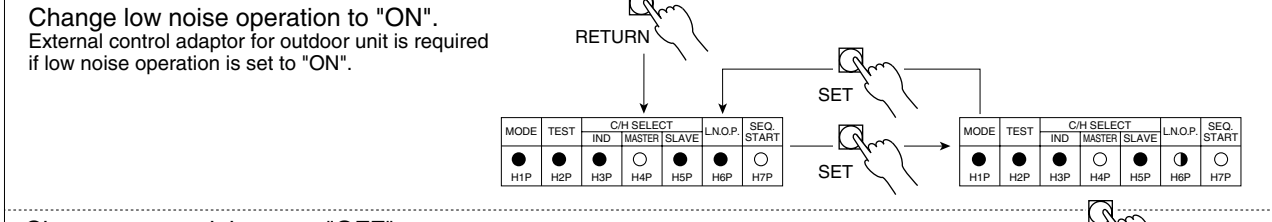
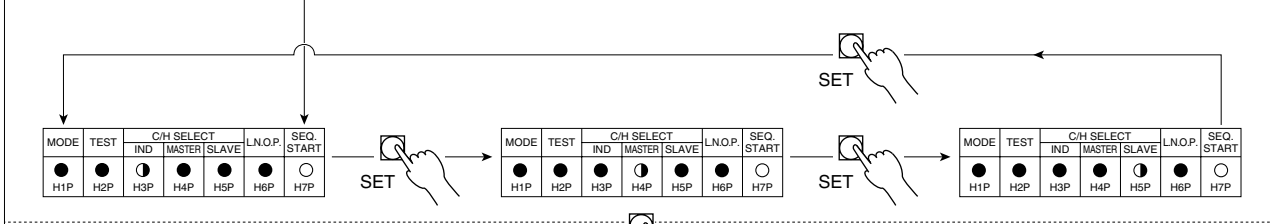
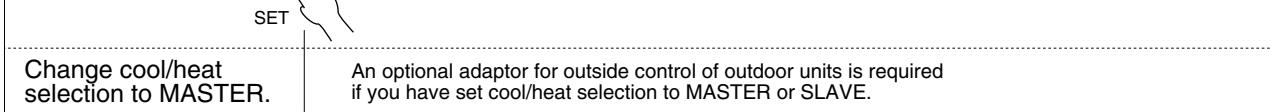
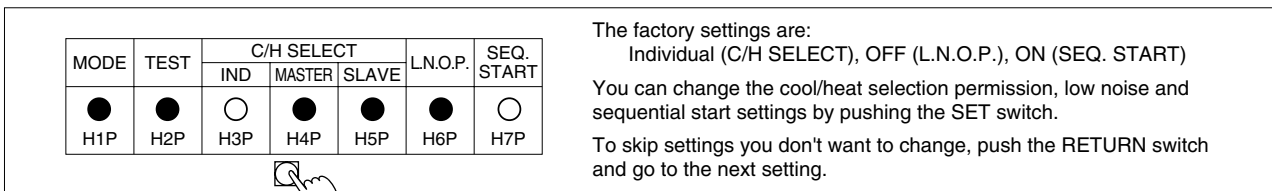
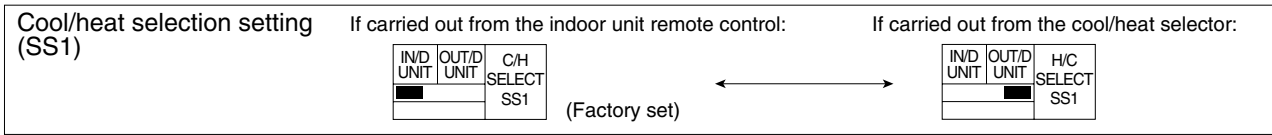

MODE

Monitor mode

MODE Push and hold for 5 sec.

Setting mode 2

(V1330)

Note: External control adaptor for outdoor unit is required if cool/heat selection set to MASTER or SLAVE, or if low noise operation is set to ON.

4.4.2 Setting Mode 2

To switch from setting mode 1 (normal) to setting mode 2, you must push and hold the next page button (BS1) for 5 seconds. (You cannot enter setting mode 2 while setting mode 1 is set.)

Setting Procedure

1. Push the SET button and match with the setting item (LED display). (All 10 settings)
↓
2. Push the RETURN button (BS3) and the present settings flicker (LED display).
↓
3. Push the SET button (BS2) and match with each setting (LED flicker display).
↓
4. Push the RETURN button (BS3) and enter the settings.
↓
5. Push the RETURN button (BS3) and return to the initial status.



Note:

1. If you become unsure of how to proceed, push the MODE button (BS1) and return to setting mode 1.
2. The initial status of setting mode 2 is the status of setting item No. 1 in mode 2.

Setting Items

	Setting item	Description	LED display							LED display							
			H1P	H2P	H3P	H4P	H5P	H6P	H7P	H1P	H2P	H3P	H4P	H5P	H6P	H7P	
1	EMG (Emergency operation 1)	Emergency operation when inverter type outdoor unit malfunctions.	○	●	●	●	●	●	●	Emergency operation (Operates by constant speed outdoor unit only.) Normal operation	○	●	●	●	●	○	●
2	Cool/heat unified address	Address for cool/heat unified operation	○	●	●	●	●	○	Address Binary number (5 digits) 5 31	0 1 2 5 31	○	●	●	●	●	○	○
3	Low noise / demand address	Address for low noise / demand operation.	○	●	●	●	○	●	Address Binary number (5 digits) 5 31	0 1 2 5 31	○	●	●	●	○	○	○
4	Forced fan switch	Indoor unit fan turns while unit is stopped.	○	●	●	○	○	○	Forced fan operation (H tap) Normal operation	○	●	●	○	○	○	○	
5	Indoor unit forced operation	Allows operation of indoor unit from outdoor unit.	○	●	●	○	○	○	Indoor unit forced operation Normal operation	○	●	●	○	○	○	○	
6	Frequency fix	Fixes compressor frequency. INV : (60Hz+OFF) STD1: (ON+OFF) STD2: (ON+OFF)	○	●	●	○	○	○	Frequency fix Normal operation	○	●	●	○	○	○	○	
7	TE setting	Low pressure setting for cooling.	○	●	○	○	○	○	High Normal (factory set)	○	●	○	○	○	○	○	
8	TC setting Note 1	High pressure setting for heating	○	●	○	○	○	○	Low	○	●	○	○	○	○	○	
9	Defrost setting Note 1	Temperature setting for defrost.	○	●	○	○	○	○	Quick defrost Normal (factory set) Slow defrost	○	●	○	○	○	○	○	
10	Air NET address	Address for Air NET	○	●	○	○	○	○	Address Binary number (6 digits) 5 63	0 1 2 5 63	○	●	○	○	○	○	○

(V0839)

No	Setting item	Description	LED display H1P H2P H3P H4P H5P H6P H7P	LED display H1P H2P H3P H4P H5P H6P H7P	LED display H1P H2P H3P H4P H5P H6P H7P
1	EMG (Emergency operation 1)	Emergency operation when Inverter type outdoor unit malfunctions.	○ ● ● ● ● ● ●	Emergency operation Normal operation	○ ● ● ● ● ● ● ○ ● ● ● ● ● ●
2	Cool/heat unified address	Address for cool/heat unified operation	○ ● ● ● ● ● ○	Address 0 Binary number 1 (6 digits)	○ ● ● ● ● ● ● ○ ● ● ● ● ● ● ○ ● ● ● ● ● ● ○ ● ● ● ● ● ●
3	Low noise / demand address	Address for low noise / demand operation	○ ● ● ● ● ● ○	Address 0 Binary number 1 (6 digits)	○ ● ● ● ● ● ● ○ ● ● ● ● ● ● ○ ● ● ● ● ● ● ○ ● ● ● ● ● ●
4	Forced fan switch	Indoor unit fan turns while unit is stopped.	○ ● ● ● ● ● ○	Forced fan operation (H tap) Normal operation	○ ● ● ● ● ● ● ○ ● ● ● ● ● ●
5	Indoor unit forced operation	Allows operation of indoor unit from outdoor unit	○ ● ● ● ● ● ○	Forced fan operation (H tap) Normal operation	○ ● ● ● ● ● ● ○ ● ● ● ● ● ●
6	Frequency fix	Fixes compressor frequency. INV : (60Hz + OFF) STD 1 : (ON+OFF) STD 2 : (ON+OFF)	○ ● ● ● ● ● ○	Frequency fix Normal operation	○ ● ● ● ● ● ● ○ ● ● ● ● ● ●
7	TE setting	Low pressure setting for cooling	○ ● ● ● ● ● ○	High Normal (factory set) Low	○ ● ● ● ● ● ● ○ ● ● ● ● ● ● ○ ● ● ● ● ● ●
8	TC setting Note 1	High pressure setting for heating	○ ● ● ● ● ● ○	Quick defrost Normal (factory set) Slow defrost	○ ● ● ● ● ● ● ○ ● ● ● ● ● ● ○ ● ● ● ● ● ●
9	Defrost setting Note 1	Temperature setting for defrost	○ ● ● ● ● ● ○	Address 0 Binary number 1 (6 digits)	○ ● ● ● ● ● ● ○ ● ● ● ● ● ● ○ ● ● ● ● ● ● ○ ● ● ● ● ● ●
10	Air Net address	Address for Air Net	○ ● ● ● ● ● ○	Address 0 Binary number 1 (6 digits)	○ ● ● ● ● ● ● ○ ● ● ● ● ● ● ○ ● ● ● ● ● ● ○ ● ● ● ● ● ●

Initial setting (EMG)

RETURN BUTTON
SET BUTTON (V0840)

4.4.3 Monitor Mode

MODE	TEST	C/H SELECT			L.N.O.P.	SEQ. START
		IND	MASTER	SLAVE		
<input checked="" type="radio"/> H1P	<input checked="" type="radio"/> H2P	<input type="radio"/> H3P	<input checked="" type="radio"/> H4P	<input checked="" type="radio"/> H5P	<input checked="" type="radio"/> H6P	<input type="radio"/> H7P

To enter the monitor mode, push the MODE button when in setting mode 1.

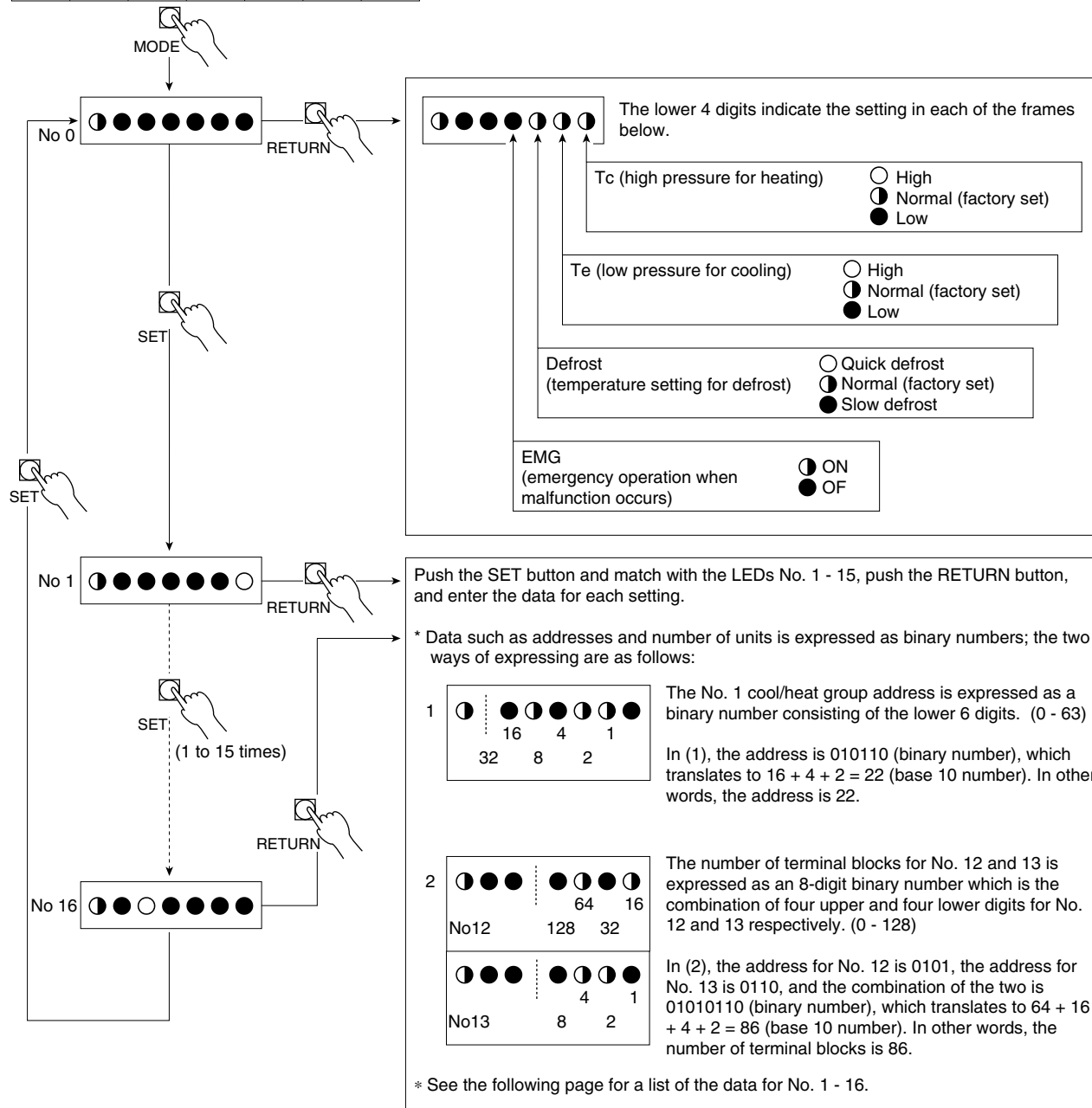

(V1331)

- After making sure the data is correct, push the RETURN button and return to No. 0, or push the MODE button and return to setting mode 1.

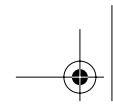

SiE33-003

Test Operation

Monitor Mode Data

Mode No.	LED	Data	Display method	Size (binary number)
No 1	○ ● ● ● ● ● ○	Cool/heat group address	0 ~ 31	Lower 6 digits
No 2	○ ● ● ● ● ○ ●	Low noise / demand address	0 ~ 31	Lower 6 digits
No 3	○ ● ● ● ● ○ ○	Not used		
No 4	○ ● ● ● ○ ● ●	Not used	0 ~ 63	Lower 6 digits
No 5	○ ● ● ● ○ ● ○	Number of connected units	0 ~ 63 units	Lower 6 digits
No 6	○ ● ● ● ○ ○ ●	Number of connected BS units	0 ~ 63 units	Lower 6 digits
No 7	○ ● ● ● ○ ○ ○	Number of connected zone units (excluding outdoor and BS units)	0 ~ 63 units	Lower 6 digits
No 8	○ ● ● ○ ● ● ●	Number of outdoor units	0 ~ 63 units	Lower 6 digits
No 9	○ ● ● ○ ● ● ○	Number of BS units	0 ~ 128 units	Lower 4 digits, upper
No 10	○ ● ● ○ ● ○ ●	Number of BS units	0 ~ 128 units	Lower 4 digits, lower
No 11	○ ● ● ○ ● ○ ○	Number of zone units (excluding outdoor and BS units)	0 ~ 63 units	Lower 6 digits
No 12	○ ● ● ○ ○ ● ●	Number of terminal blocks	0 ~ 128 units	Lower 4 digits, upper
No 13	○ ● ● ○ ○ ● ○	Number of terminal blocks	0 ~ 128 units	Lower 4 digits, lower
No 14	○ ● ● ○ ○ ○ ●	Not used		
No 15	○ ● ● ○ ○ ○ ○	Not used		
No 16	○ ● ○ ● ● ● ●	Not used		



General Information

67



4.5 Cool / Heat Mode Selection

The R-407C VRV PLUS Series offers the following four cool/heat mode selections.

1. Setting of cool/heat by individual outdoor unit system by indoor unit remote control
2. Setting of cool/heat by individual outdoor unit system by cool/heat selector
3. Setting of cool/heat by outdoor unit system group in accordance with group master outdoor unit by indoor unit remote control
4. Setting of cool/heat by outdoor unit system group in accordance with group master outdoor unit by cool/heat selector

Each of these setting methods is explained in detail below.

(For 3 and 4 be sure to perform power supply reset after changing settings.)

4.5.1 Setting of Cool / Heat by Individual Outdoor Unit System by Indoor Unit Remote Control

- Doesn't matter whether or not there is outdoor - outdoor unit wiring.
- Set SS1 of the outdoor unit PCB to "IN / D UNIT" (factory set).
- In setting mode 1, set cool/heat selection to "IND" (factory set).

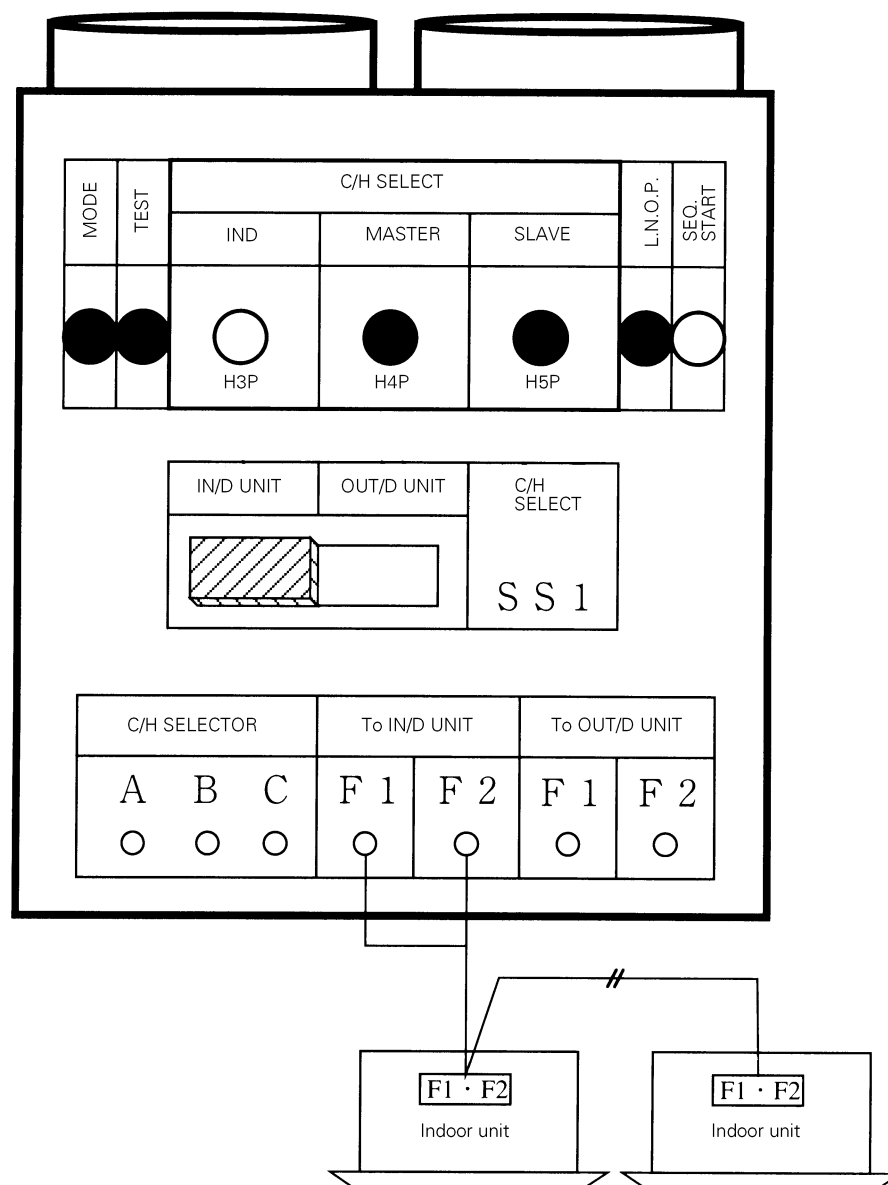

(V1332)

4.5.2 Setting of Cool / Heat by Individual Outdoor Unit System by Cool/Heat Selector

- Doesn't matter whether or not there is outdoor - outdoor unit wiring.
- Set SS1 of the outdoor unit PC board to "OUT / D UNIT."
- In setting mode 1, set cool/heat selection to "IND" (factory set).

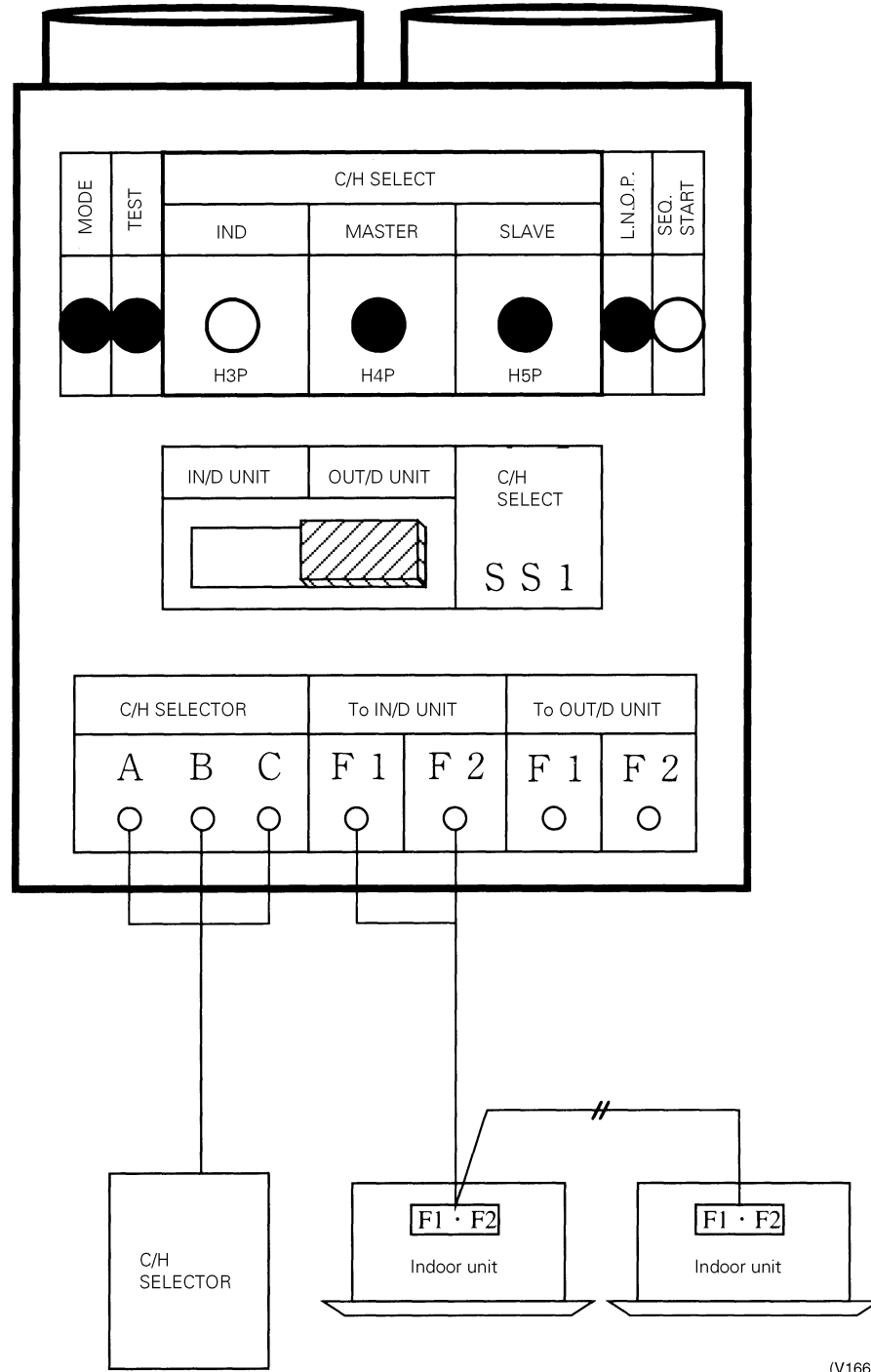

4.5.3 Setting of Cool / Heat by Outdoor Unit System Group in Accordance with Group Master Outdoor Unit by Indoor Unit Remote Control

- Install the External control adaptor for outdoor unit on either the outdoor - outdoor, indoor - outdoor, or indoor - indoor transmission line.
- Set SS1 of the outdoor unit PCB to "IN / D UNIT" (factory set).
- In setting mode 1, set the outdoor unit you want to give cool/heat selection permission to as the group master, and set the other outdoor units as group slave units.
- Set SS1 of the External control adaptor for outdoor unit to "BOTH" (factory set) or "C / H." Set SS2 to "OFF" (factory set).

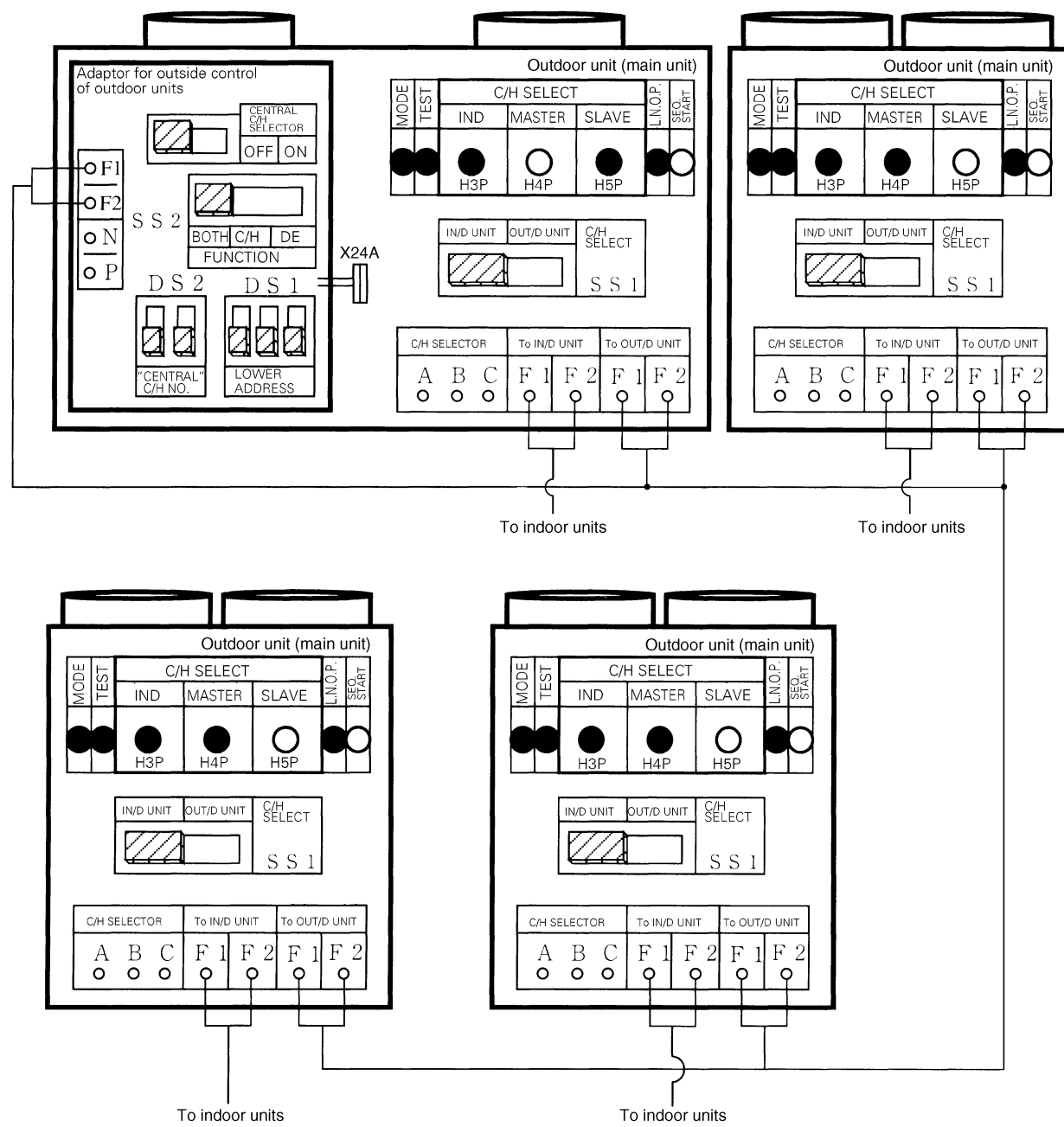

(V1333)

4.5.4 Setting of Cool / Heat by Outdoor Unit System Group in Accordance with Group Master Outdoor Unit by Cool/Heat Selector

- In addition to 1.5.3, change the following:
- Install a cool / heat selector to the group master outdoor unit.
- Set SS1 of the group master outdoor unit's PCB to "OUT / D UNIT."

Supplement

■ Supplement to 1.5.3 and 1.5.4

If using several adaptor PCB and you want to select cool/heat mode for each adaptor PCB, set DS1 / DS2 of the adaptor PCB and the cool/heat group address on the outside unit's PCB to the same setting in setting mode 2.

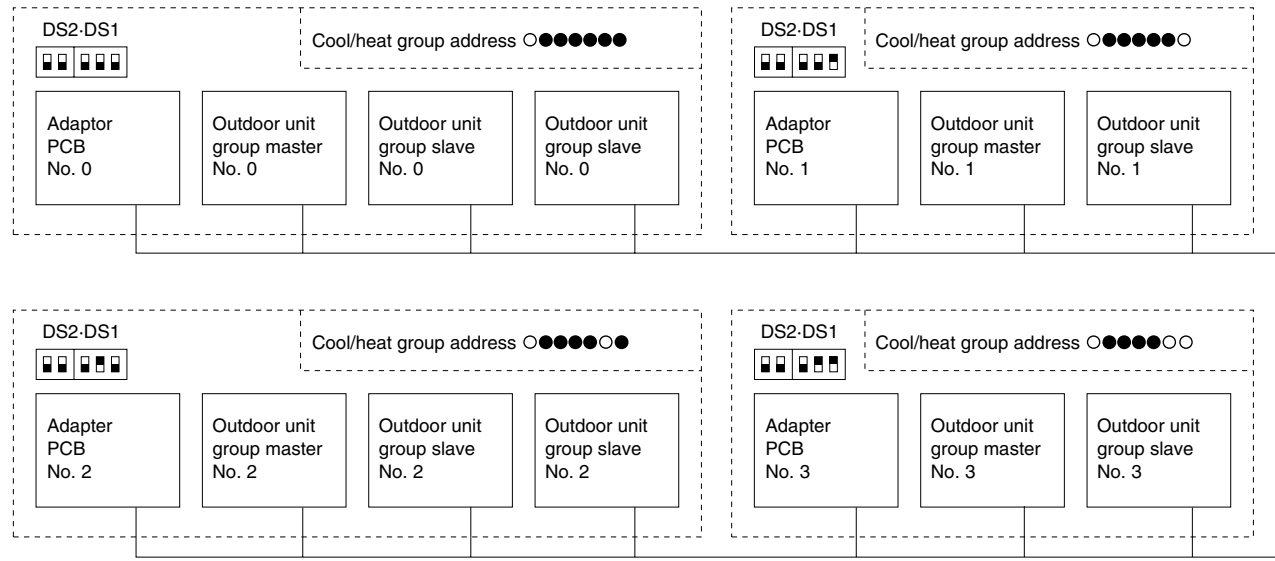

(V1334)



Test Operation

SiE33-003

Setting Method

1.5.3 and 1.5.4 address setting method (combine lower 5 digits as binary number)

Address No.	Outdoor unit PC board LED Set in setting mode 2		PC board adaptor	
	DS2	DS1	DS2	DS1
No 0				0
No 1				1
No 2				2
No 3				3
No 4				4
}				
No30				30
No31				31

○ On ● Off



(The black part represents the switch.)

(V1335)



4.6 Low Noise Operation

By connecting the external contact input to the low noise input of the outdoor unit external control adaptor for outdoor unit (optional), you can save power and lower operating noise by 2 -3 dB.

Instructions for Demand Control Operation

1. Outdoor unit field setting

- ◆ Setting mode 1: Set low noise operation to "ON."
- ◆ Setting mode 2: Match low noise operation and demand control address with address of outdoor unit external control adaptor.

2. Outdoor unit external control adaptor setting

- ◆ Function switch (SS1)
Set to "BOTH" or "DE."
- ◆ Address setting switches (DS1, DS2)
Match with outdoor unit low noise operation and demand control address.

3. Short-circuit the low noise input of outdoor unit external control adaptor for outdoor unit.

Low Noise Control System Example

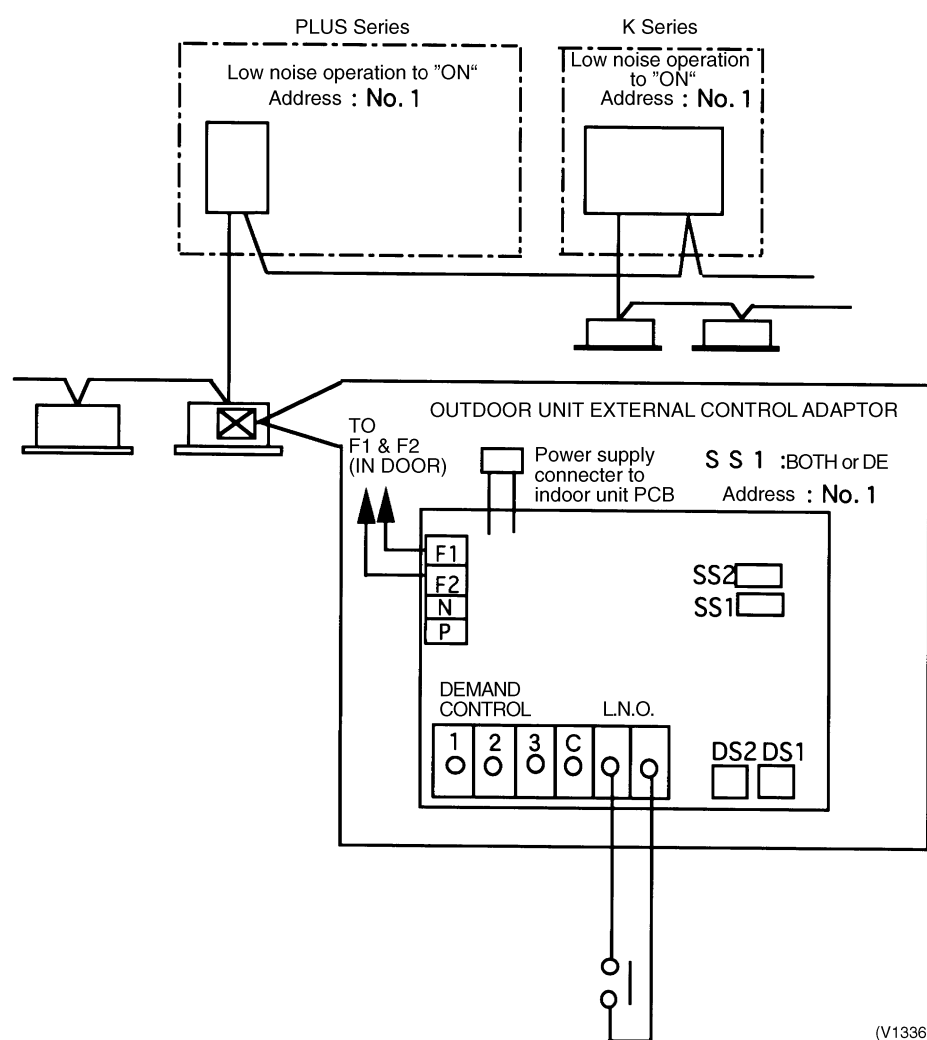

4.7 Demand Control

By connecting the external contact input to the demand input of the outdoor unit external control adaptor (option), the compressor operating conditions can be controlled for reduced power consumption.

- Demand 1 Approximately 70% level
- Demand 2 Approximately 40% level
- Demand 3 Forced thermostat OFF

Instructions for Demand Control Operation

1. Outdoor unit field setting

- ◆ Setting mode 1: Set low noise operation to "ON."
- ◆ Setting mode 2: Match low noise operation and demand control address with address of outdoor unit external control adaptor.

2. Outdoor unit external control adaptor setting

- ◆ Function switch (SS1)
Set to "BOTH" or "DE."
- ◆ Address setting switches (DS1, DS2)
Match with outdoor unit low noise operation and demand control address.

3. Select one from demand input terminals 1 through 3 on the outdoor unit external control adaptor, and short the corresponding terminals.

- Demand 1 Short 1-C.
- Demand 2 Short 2-C.
- Demand 3 Short 3-C.

Demand Control System Example

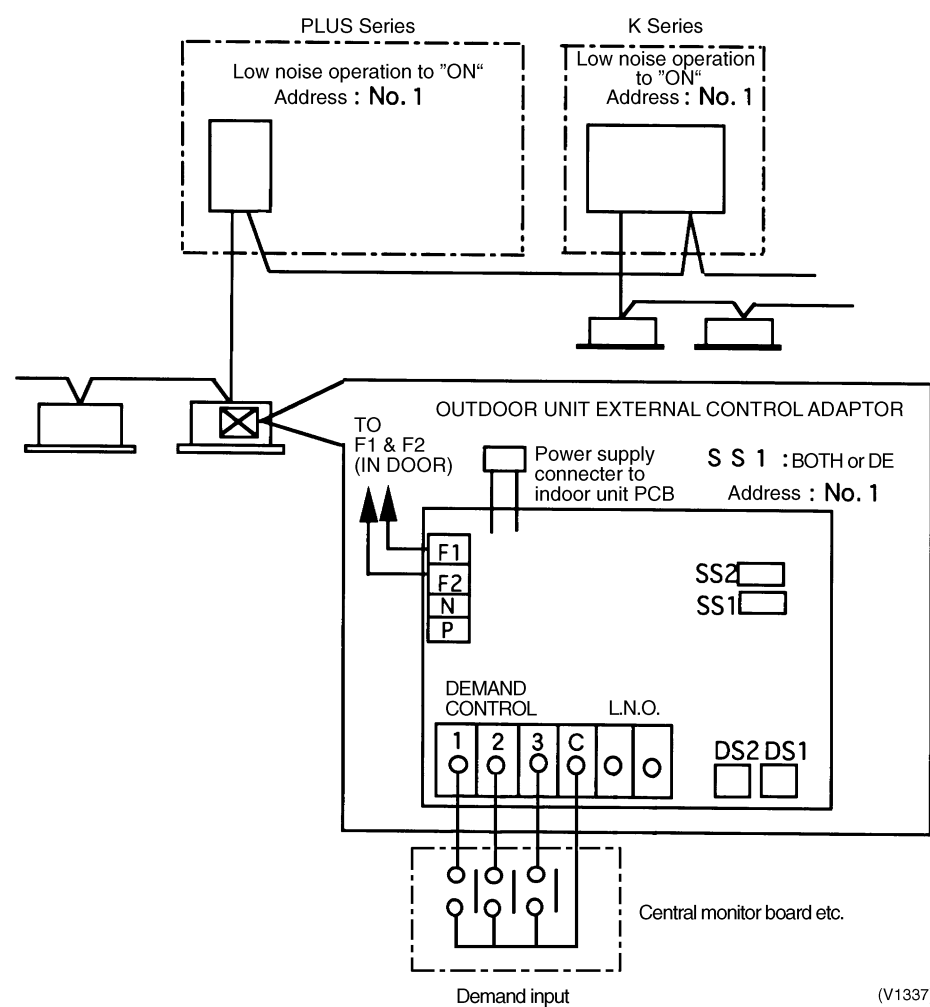

4.8 Sequential Start

- Separates path timing of commercial power supply compressors by 3 seconds each in order to prevent overcurrent when more than 1 compressor are to be started at the same time.
- Improved wiring system enables sequential start of up to 10 outdoor units.

If you want to carry out sequential start, connect outdoor unit - outdoor unit transmission wiring as shown below.

The outdoor unit PC board (EC) is factory set to "sequential start ON."

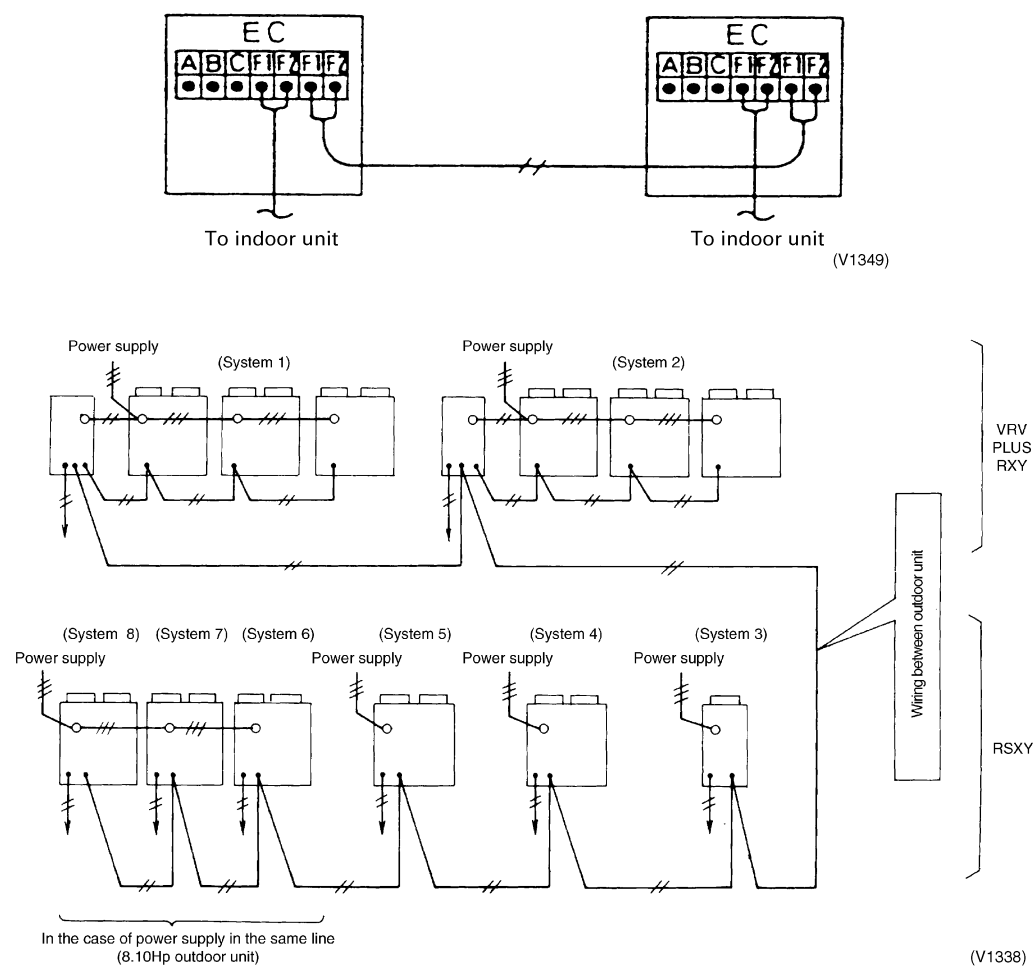

4.9 Wiring Check Operation

If within 12 hours of stopping cooling or heating, be sure to run all indoor units in the system you want to check in the fan mode for about 60 minutes in order to prevent mis-detection.

Operation Method

1. In the monitor mode, check the number of connected indoor units. (See monitor mode.)
2. Push and hold the WIRING CHECK button (BS4) for 5 seconds to perform wiring check operation. While running, TEST (H2P) lights and goes off when finished. If TEST (H2P) flickers (wiring check operation failure), push and hold the RESET button (BS5) for 5 seconds, and then repeat the procedure from the beginning.
3. About 1 minute after you finish running the system, once again check the number of connected indoor units in the monitor mode and make sure the number agrees with the first time you checked. If not, it indicates that there is a wiring mistake. Fix the wiring of the indoor unit whose remote control displays "UF" when its ON/OFF switch is turned ON.

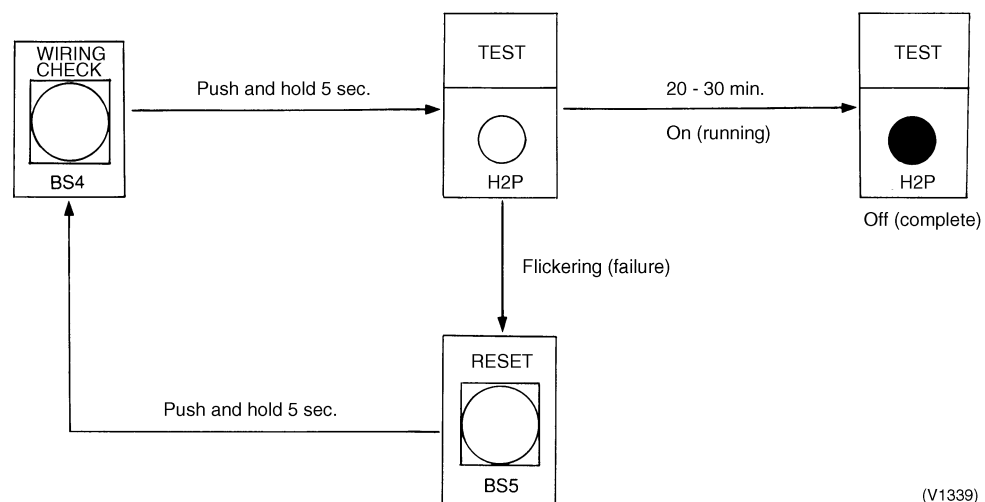

(V1339)

i **Note:** Other settings are not accepted during wiring check operation.

4.10 Additional Refrigerant Charge Operation

[Work procedure]

- Conduct ordinary refrigerant charge.
With the outdoor unit in non-operating condition, charge refrigerant from the liquid-side stop valve service port.
(Keep the stop valves on both liquid and gas sides closed.)
 - **Conduct the following operation only when the entire amount of refrigerant could not be charged with the compressor in non-operating condition (otherwise equipment damage can result).**
- Turn on the power switches of the indoor and outdoor units, and fully open the gas-side stop valve.
(Keep the liquid-side stop valve closed.)

3. Set the service mode.

In service mode 1, press the "MODE" button for 5 seconds to enter service mode 2.	○ ● ● ● ● ● ● ●
Press the "SET" button to set the LED indicators to the "additional refrigerant charge operation" indication.	○ ● ○ ● ○ ● ●
Press the "RETURN" button.	○ ● ● ● ● ● ● ●
Press the "SET" button to set the LED indicators as shown at right.	○ ● ● ● ● ● ● ●
Press the "RETURN" button to end the setting operation.	○ ● ● ● ● ● ○ ●
Press the "RETURN" button again to start operation.	● ● ● ● ● ● ● ●
Low pressure level is indicated during operation.	Higher than 3.5k
	3.5k or less
	2.5k or less
	1.5k or less
Operation ends (after 30 minutes). (Pressure level immediately before is indicated by flashing LEDs.)	○ ○ ● ● ● ● ● ● This LED indication shows that the operation stopped with pressure level at [2.5 k or lower].
Push "Mode" button once to complete additional refrigerant change.	○ ● ● ● ● ○ ●

- The refrigerant charge is completed when the specified amount of refrigerant is added. If the refrigerant charge operation is not completed in 30 minutes, make the settings again and restart the operation.
(When the Confirmation button is pressed during additional refrigerant charge operation, the operation stops.)
- Disconnect the refrigerant charge hose, then fully open the liquid-side stop valve.

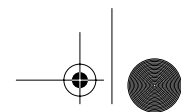

4.11 Refrigerant Recovery Mode

- The electronic expansion valves in the indoor and outdoor units are fixed in the fully open position for refrigerant recovery.

[Work procedure]

1. Stop equipment operation.

2. Set the service mode.

In service mode 1, press the "MODE" button for 5 seconds to enter service mode 2.	○ ● ● ● ● ● ●
Press the "SET" button to set the LED indicators to the "refrigerant recovery mode" indication.	○ ● ○ ● ○ ● ○
Press the "RETURN" button.	○ ● ● ● ● ● ●
Press the "SET" button to set the LED indicators as shown at right.	○ ● ● ● ● ● ●
Press the "RETURN" button to end the setting operation.	○ ● ● ● ● ○ ●

3. Turn off the power switches of the indoor and outdoor units.
(Turn off the power switch of one unit, then turn off the power switch of the other unit within 10 minutes.)

4. Conduct refrigerant recovery.

5.

Press the "RETURN" button again to return to initial status.	○ ● ● ● ● ● ●
--	---------------

- Cancel the setting in the setting mode or cancel the mode by conducting power reset of the outdoor unit.

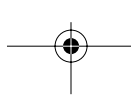

4.12 Indoor Field Setting





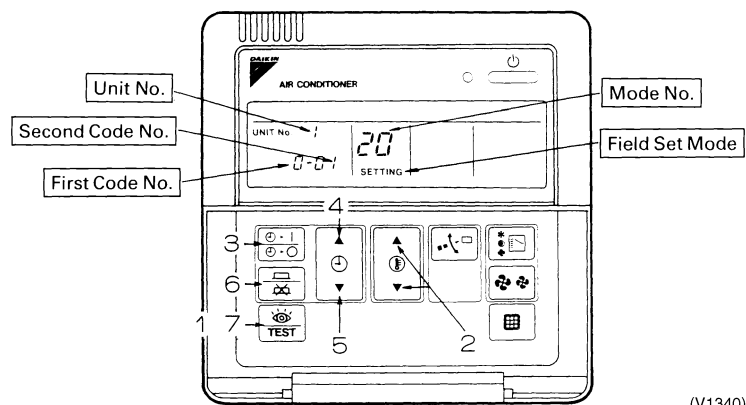

Making a field setting

Field settings must be made by remote control if optional accessories have been installed on the indoor unit, or if the indoor unit or HRV unit's individual functions have been modified.

4.12.1 Wired Remote Control <BRC1A51>



(V1340)

1. When in the normal mode, push the  button for 4 seconds or more, and operation then enters the "field set mode."
2. Select the desired "mode No." with the  button.
3. During group control and you want to set by each individual indoor unit (when mode No. 20, 21, 22, 23, 25 has been selected), push the time mode  button and select the "indoor unit No." to be set.
Note: This operation is not required when setting as a group.
4. Push the  button and select the first code No.
5. Push the  button and select the second code No.
6. Push the timer  button one time and "define" the currently set contents.
7. Push the  button to return to the normal mode.

(Example)

When setting the filter sign time to "Filter Dirtiness-High" in all group unit setting, set the Mode No. to "10", Mode setting No. to "0" and setting position No. to "02".

4.12.2 Wired Remote Control – Heat Recovery Ventilation <BRC301B61>

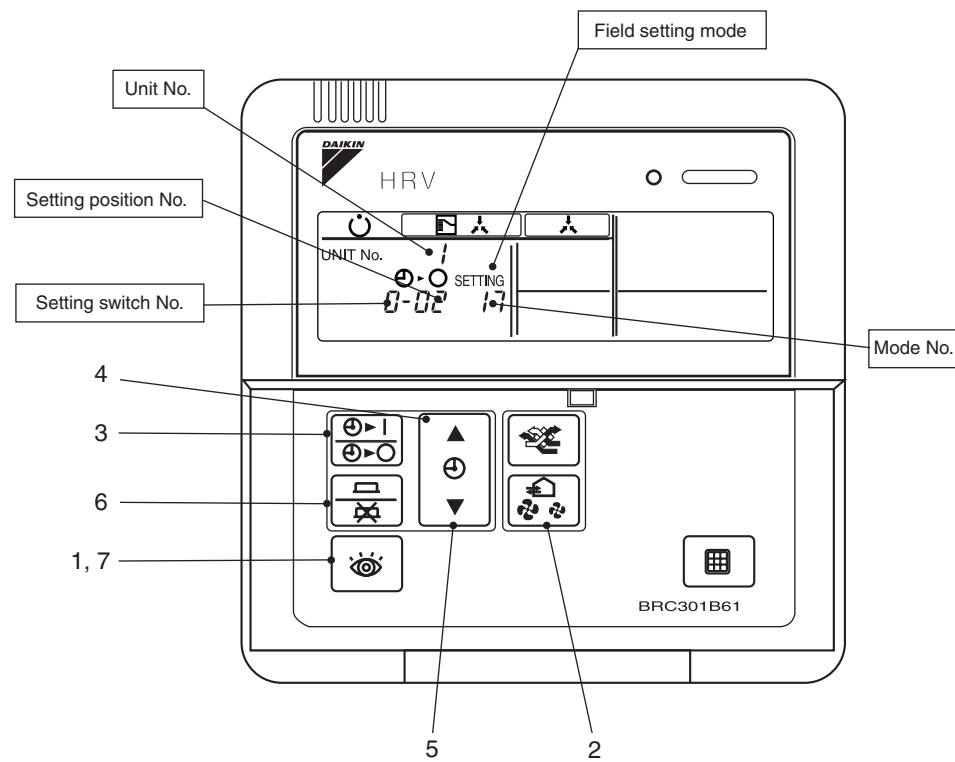

(V1341)

Setting procedure

1. In the Normal Mode, press the button for more than 4 seconds to enter the Local Setting mode.
2. Using the (Mode No. UP) and [Ventilation Volume] (Mode No. DOWN) buttons to select a desired Mode No.
3. To set individual Heat Recraim Ventilation units in group control (select Mode Nos. 27 and 28 (Heat Recraim Ventilation)), press the button and choose the Unit No. to set. (This step is not necessary in all group unit setting.)
4. Press the UP button to select a Setting Switch No.
5. Press the DOWN button to select a Setting Position No.
6. Press the button once to enter the settings.
7. Depress the button for about 1 second to return to the Normal Mode.

(Example)

When setting the filter sign time to "Filter Dirtiness - High" in all group unit setting, set the Mode No. to "17," Mode Setting No. to "0" and Setting Position No. to "02."

4.12.3 Infrared Remote Control — Indoor Unit

BRC7A type

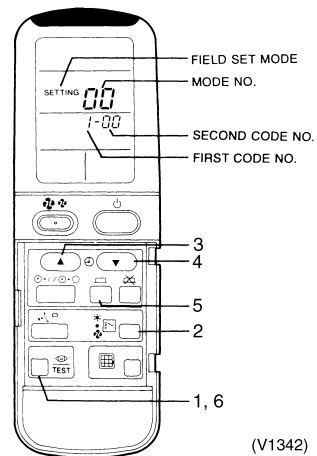

(V1342)

1. When in the normal mode, push the button for 4 seconds or more, and operation then enters the "field set mode."
2. Select the desired "mode No." with the button.
3. Pushing the button, select the first code No.
4. Pushing the button, select the second code No.
5. Push the timer button and check the settings.
6. Push the button to return to the normal mode.

BRC7C type

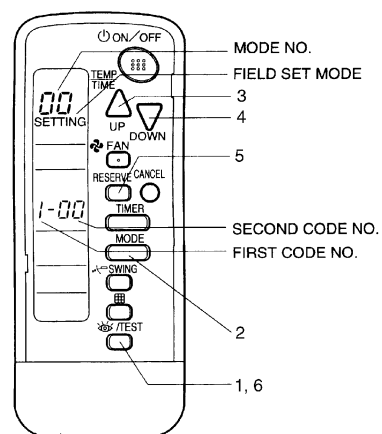

(V0915)

1. When in the normal mode, push the button for 4 seconds or more, and operation then enters the "field set mode."
2. Select the desired "mode No." with the button.
3. Pushing the button, select the first code No.
4. Pushing the button, select the second code No.
5. Push the timer button and check the settings.
6. Push the button to return to the normal mode.

4.12.4 Setting Contents and Code No. – VRV Unit

Mode No. Note)1	FIRST CODE No.	Description of Setting	SECOND CODE NO. Note)2								
			01		02		03		04		
10(20)	0	Filter Contamination-Heavy/ Light (Setting for display time to clean air filter) (Sets display time to clean air filter to half when there is heavy filter contamination.)	Ultra-Long-Life Type	Light	Approx. 10,000 hours	Heavy	Approx. 5,000 hours	—		—	
		Long-Life Type	Light	Approx. 2,500 hours	Heavy	Approx. 1,250 hours	—		—		
		Standard Type	Light	Approx. 200 hours	Heavy	Approx. 100 hours	—		—		
	1	Long-life filter type (Setting of filter sign indication time) (Change setting when Ultra-long-life filter is installed)	Long-Life Filter	Long-Life Filter	Ultra-Long- Life Filter	—		—		—	
	2	Thermostat Sensor in Remote Control	Use	Use	Not Use	—		—		—	
3	Display Time to Clean Air Filter Calculation (Set when filter sign is not to be displayed)	Display	Display	Do not Display	—		—		—		
12(22)	0	Optional accessories output selection (field selection of output for adaptor for wiring)	Indoor Unit Turned ON by Thermostat		—		Operation Output		Malfunction Output		
	1	ON/OFF Input from Outside (Set when ON/OFF is to be controlled from outside.)	Forced Off		ON/OFF Control		External Protection Device		—		
	2	Thermostat Differential Changeover (Set when remote sensor is to be used.) FXYC, FXYP, FXYK, FXYH only	1°C		0.5°C		—		—		
	4	Automatic mode differential (automatic temperature differential setting for VRV system heat recovery series cool/heat)	01 : 0	02 : 1	03 : 2	04 : 3	05 : 4	06 : 5	07 : 6	08 : 7	
	5	Power failure automatic reset (Auto Restart)	No equipped		Equipped		—		—		
13(23)	0	High Air Outlet Velocity (Set when installed in a place with ceiling higher than 2.7m.)	N		H		—		—		
	1	Selection of Air Flow Direction (Set when a blocking pad kit has been installed) FXYF only	F (4 directions)		T (3 directions)		W (2 directions)		—		
	3	Air Flow Direction Adjustment (Set at installation of decoration panel.) FXYK only	Equipped		Not Equipped		—		—		
	4	Field set air flow position setting	Draft Prevention		Standard		Ceiling Soiling Prevention		—		
	5	Field set fan speed selection (fan speed control by air discharge outlet for phase control)	Standard		Optional Accessory 1		Optional Accessory 2		—		
15(25)	1	Humidifying with thermostat OFF	Not Equipped		Equipped		—		—		
	3	Drain Pump humidifier interlock selection	Not Equipped		Equipped		—		—		

**Notes:**

- Setting is carried out in the group mode. however, if the mode number inside the parentheses is selected, indoor units can also be set individually.
- The SECOND CODE number. is set to "□" when shipped from the factory.
- Do not make any settings not given in the table above.
- Not displayed if the indoor unit is not equipped with that function.
- When returning to the normal mode. "88" may be displayed in the LCD in order for the remote control to initialize itself.

4.12.5 Field Setting, Service Mode – Heat Recovery Ventilation (HRV)

1. Field setting
Used for initial setting of heat recovery ventilation unit.
2. Service mode
Used for confirmation of unit Nos. in the group and reallocation of unit Nos.

List of Field Setting and Service Mode

Heat Recovery Ventilation (HRV)	Mode No.	Setting switch No.	Setting contents	Setting position					
				01	02	03	04	05	06
17(27)	0	0	Filter cleaning time setting	Approx. 2500 hr.	Approx. 1250 hr.	No counting	—	—	—
	2		Pre-cool/pre-heat On/Off setting	Off	On	—	—	—	—
	3		Pre-cool/pre-heat time (min.) setting	30 min.	45 min.	60 min.	—	—	—
	4		Fan speed initial setting	Normal	Ultra-High	—	—	—	—
	5		Yes / No setting for direct duct Connection with VRV system Setting for cold areas (Fan operation selection for heater thermostat OFF)	No duct (Air flow setting)	With duct (fan off)	—	—	—	—
				—	—	No duct		With duct	
	7		Centralized / individual setting	Centralized	Individual	—	—	—	—
	8		Centralized zone interlock setting	No	Yes	Priority on Operation	—	—	—
	9		Pre-heat time extension setting	0	30 min.	60 min.	90 min.	—	—
	18(28)	0		External signal setting JC / J2	Last command	Priority on external input	—	—	—
1			Setting for direct power-on	Off	On	—	—	—	—
2			Auto restart setting	Off	On	—	—	—	—
4			Indication of ventilation mode / Not indication	Indication	No Indication	—	—	—	—
7			Fresh up air supply / exhaust setting	No Indication	No Indication	Indication	Indication	—	—
				Supply	Exhaust	Supply	Exhaust	—	—
8		External input terminal function selection (between J1 and J2)	Fresh up	Overall alarm	Overall malfunction	Forced off	Fan forced off	Air flow increase	
9		KRP50-2 output switching selection (between 1 and 3)	Humidify	Abnormal	Fan on / off	—	—	—	
19(29)	0		Air flow setting	Low	Low	Low	Low	High	High
	2		Ventilation mode setting	Automatic	Total heat exchange	Normal	—	—	—
	3		Fresh up operation	OFF	ON	—	—	—	—
	8		Electric heater setting	No delay	No delay	ON / OFF Delay	ON / OFF Delay	—	—



Note:

1. All the settings can be made by the remote control for VRV and HRV unit.
The setting of mode No. 19 (29) and 40 can be made only by the remote control for VRV unit. The mode No. 30 is used for the individual setting such as the calculation of power bill, etc.
2. The mode No. in () is used for making individual setting of each unit.
3. **Group number setting for centralized control**
 1. Mode no. 00: Group control
 2. Mode no. 30: Individual control

* Regarding the setting procedure, refer to the section "Group number setting for centralized control" in the operating manual of either the on / off control or the central control.









Caution

1. The setting positions are set at "01" at the factory.
The ventilation air flow, however, is set at "05" (medium) in the HRV unit. When lower or higher setting is desired, change the setting after installation.

4.13 Centralized Control Group No. Setting

BRC1A51-52



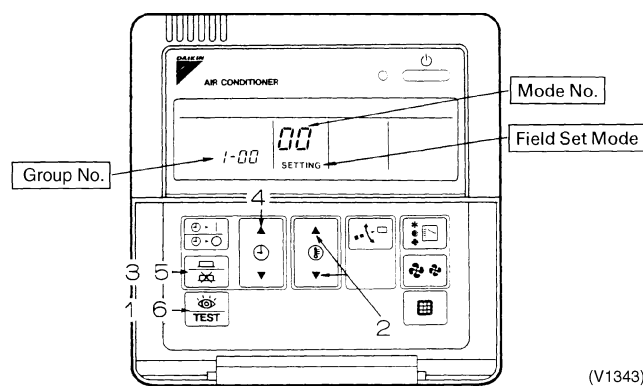

- If carrying out centralized control by central remote control or unified ON/OFF control, group No. must be set for each group individually by remote control.
 - Group No. setting by remote control for centralized control
1. When in the normal mode, push the  button for 4 seconds or more, and operation then enters the "field setting mode."
 2. Set mode No. "00" with the  button. *
 3. Push the  button to inspect the group No. display.
 4. Set the group No. for each group with the  button (The group No. increases in the manner of 1-00, 1-01, ..., 1-15, 2-00, ..., 4-15. However, the unified ON/OFF control displays only the group No. within the range selected by the switch for setting each address.)
 5. Push the timer  button to define the selected group No.
 6. Push the  button to return to the normal mode.



(V1343)

- Even if not using a remote control, connect the remote control when setting the group No., set the group No. for centralized control, and disconnect after making the setting.
- Set the group No. after turning on the power supply for the central remote control, unified ON/OFF control, and indoor unit.

BRC7A Type





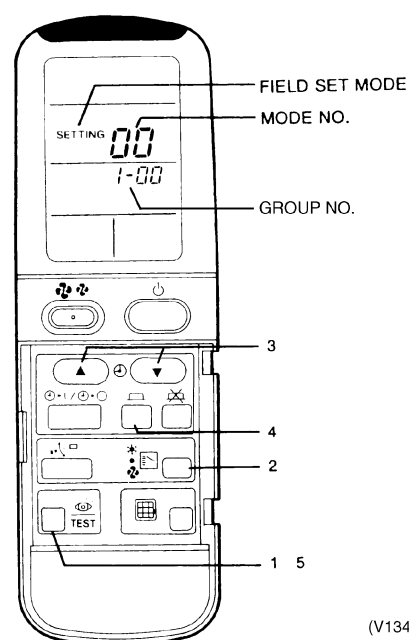

- Group No. setting by infrared remote control for centralized control
1. When in the normal mode, push  button for 4 seconds or more, and operation then enters the "field set mode."
 2. Set mode No. "00" with  button.
 3. Set the group No. for each group with  button (advance/backward).
 4. Enter selected group numbers by pushing  button.
 5. Push  button and return to the normal mode.

BRC7A Type



(V1344)

BRC7C Type

- Group No. setting by infrared remote control for centralized control
- 1. When in the normal mode, push  button for 4 seconds or more, and operation then enters the "field set mode."
- 2. Set mode No. "00" with  button.
- 3. Set the group No. for each group with   button (advance/backward).
- 4. Enter the selected group numbers by pushing  button.
- 5. Push  button and return to the normal mode.

BRC7C Type

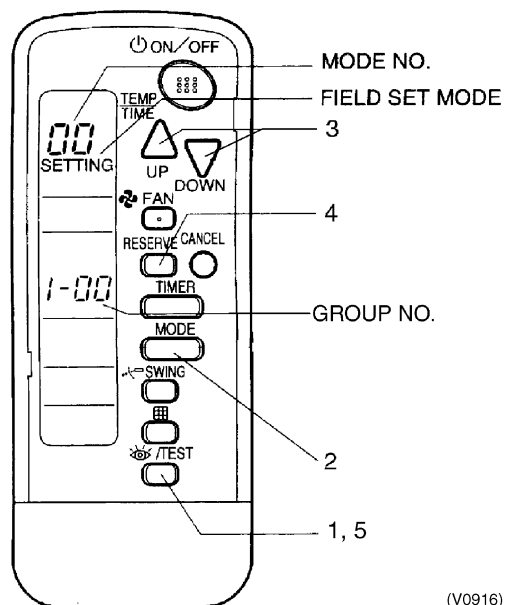

(V0916)

Group No. Setting Example

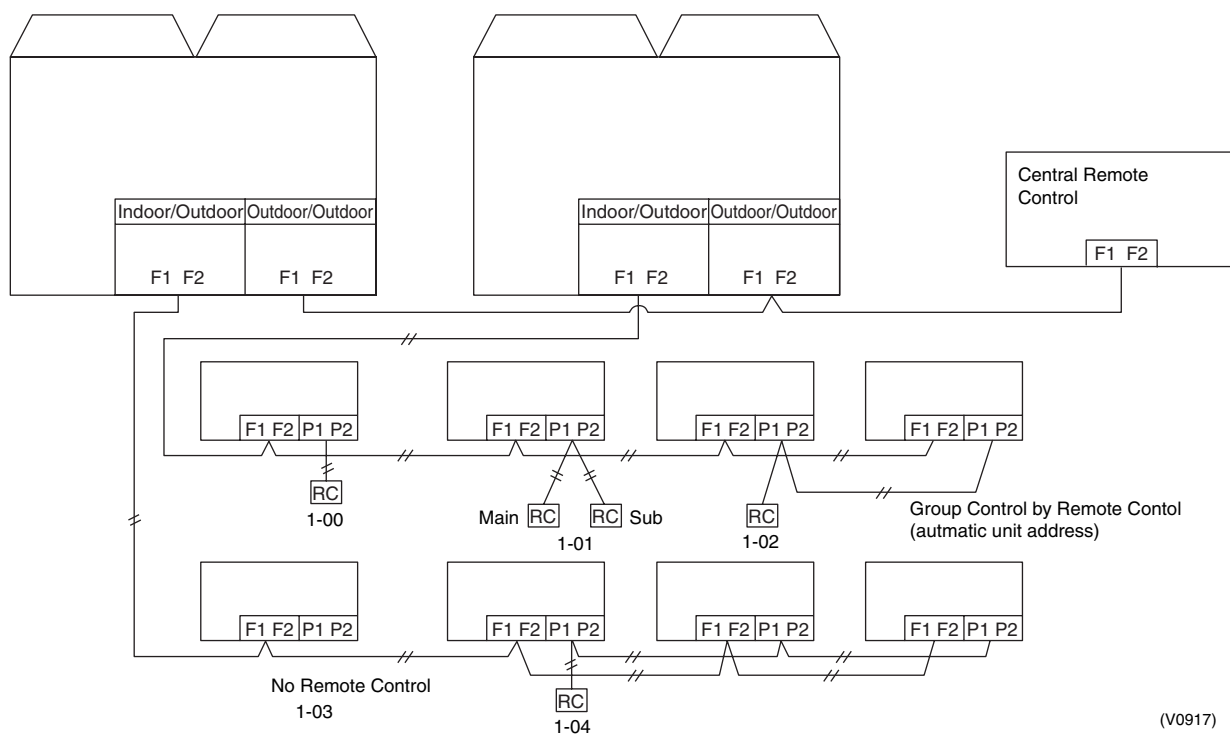

(V0917)

- If you have to set the address for each unit for calculating cost, etc., set the mode No. to "30."



Caution

When turning the power supply on, the unit may often not accept any operation while "88" is displaying after all indications were displayed once for about 1 minute on the liquid crystal display. This is not an operative fault.

4.14 Contents of Control Modes

Twenty modes consisting of combinations of the following five operation modes with temperature and operation mode setting by remote control can be set and displayed by operation modes 0 through 19.

- ◆ ON/OFF control impossible by remote control
Used when you want to turn on/off by central remote control only.
(Cannot be turned on/off by remote control.)
- ◆ OFF control only possible by remote control
Used when you want to turn on by central remote control only, and off by remote control only.
- ◆ Centralized
Used when you want to turn on by central remote control only, and turn on/off freely by remote control during set time.
- ◆ Individual
Used when you want to turn on/off by both central remote control and remote control.
- ◆ Timer operation possible by remote control
Used when you want to turn on/off by remote control during set time and you do not want to start operation by central remote control when time of system start is programmed.

How to Select Operation Mode

Whether operation by remote control will be possible or not for turning on/off, controlling temperature or setting operation mode is selected and decided by the operation mode given on the right edge of the table below.

Example

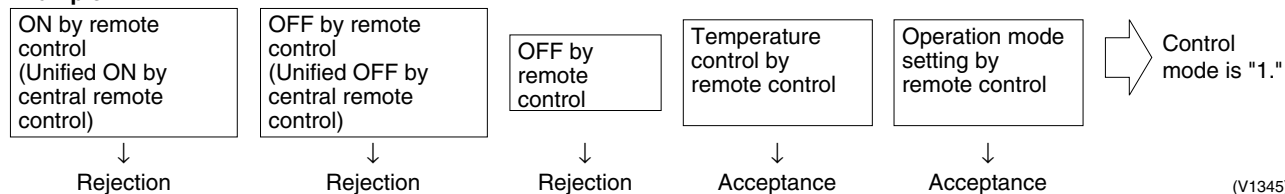

Control mode	Control by remote control					Control mode
	Operation		OFF	Temperature control	Operation mode setting	
	Unified operation, individual operation by central remote control, or operation controlled by timer	Unified OFF, individual stop by central remote control, or timer stop				
ON/OFF control impossible by remote control	Rejection (Example)	Rejection (Example)	Rejection (Example)	Rejection	Acceptance	0
					Rejection	10
					Acceptance (Example)	1 (Example)
OFF control only possible by remote control	Acceptance	Acceptance	Acceptance	Acceptance	Rejection	2
					Rejection	12
					Acceptance	3
Centralized	Acceptance	Acceptance	Acceptance	Acceptance	Rejection	4
					Rejection	14
					Acceptance	5
Individual	Acceptance	Acceptance	Acceptance	Acceptance	Rejection	6
					Rejection	16
					Acceptance	7 *1
Timer operation possible by remote control	Acceptance (During timer at ON position only)	Acceptance (During timer at ON position only)	Acceptance	Acceptance	Rejection	8
					Rejection	18
					Acceptance	9
					Rejection	19

Do not select "timer operation possible by remote control" if not using a remote control. Operation by timer is impossible in this case.

*1. Factory setting

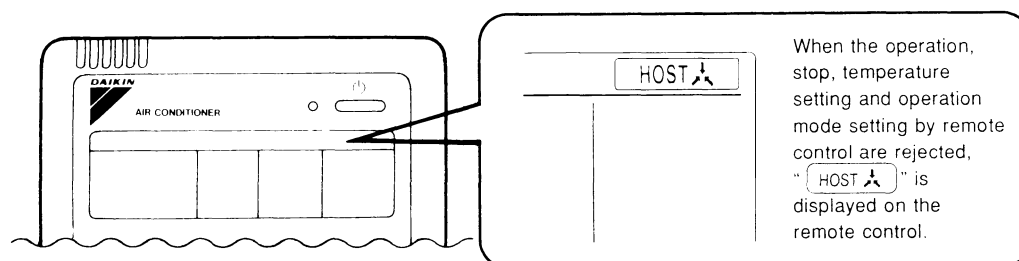
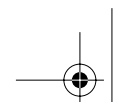

(V1346)

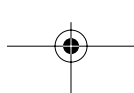
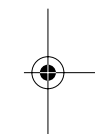

5. Caution for Refrigerant Leaks

5.1 Caution for Refrigerant Leaks

5.1.1 Introduction

(Points to note in connection with refrigerant leaks)

The VRV System, like other air conditioning systems, uses R-407C as refrigerant. R-407C itself is an entirely safe non-toxic, non-combustible refrigerant. Nevertheless care must be taken to ensure that air conditioning facilities are installed in a room which is sufficiently large. This assures that the maximum concentration level of refrigerant gas is not exceeded, in the unlikely event of major leak in the system and this in accordance to the local applicable regulations and standards.

5.1.2 Maximum Concentration Level

The maximum charge of refrigerant and the calculation of the maximum concentration of refrigerant is directly related to the humanly occupied space in to which it could leak.

The unit of measurement of the concentration is kg/m^3 (the weight in kg of the refrigerant gas in 1m^3 volume of the occupied space).

Compliance to the local applicable regulations and standards for the maximum allowable concentration level is required.

In Japan the maximum allowed concentration level of refrigerant to a humanly space for R-407C is limited to 0.3 kg/m^3

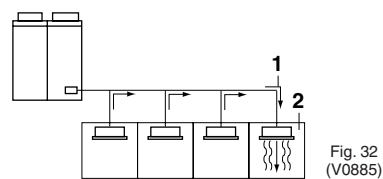

1. Direction of The Refrigerant Flow
2. Room where refrigerant leak has occurred (outflow of all the refrigerant from the system)

Fig. 32
(V0885)

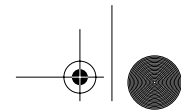
**5.1.3 Procedure for Checking Maximum Concentration**

Check the maximum concentration level in accordance with steps 1 to 4 below and take whatever action is necessary to comply.

Step 1

Calculate the amount of refrigerant (kg) charged to each system separately.

amount of refrigerant in a single unit system (amount of refrigerant with which the system is charged before leaving the factory)	+	additional charging amount (amount of refrigerant added locally in accordance with the length or diameter of the refrigerant piping)	=	total amount of refrigerant (kg) in the system
---	---	--	---	--



Note: ■ Where a single refrigerant facility is divided into 2 entirely independent refrigerant systems then use the amount of refrigerant with which each separate system is charged.

Step 2

Calculate the smallest room volume (m³)

In case like the following, calculate the volume of (A), (B) as a single room or as the smallest room.

A. Where there are no smaller room divisions

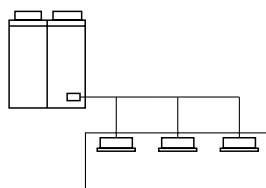

Fig. 33
(V0886)

B. Where there is a room division but there is an opening between the rooms sufficiently large to permit a free flow of air back and forth.

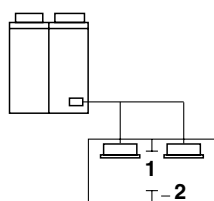

Fig. 34
(V0887)

1. Opening between rooms
2. Partition

(Where there is an opening without a door or where there are openings above and below the door which are each equivalent in size to 0.15% or more of the floor area.)

Step 3

Calculating the refrigerant density using the results of the calculations in steps 1 and 2 above.

$$\frac{\text{total volume of refrigerant in the refrigerant system}}{\text{size (m}^3\text{) of smallest room in which there is an indoor unit installed}} \leq \text{maximum concentration level (kg/m}^3\text{)}$$

If the result of the above calculation exceeds the maximum concentration level then make similar calculations for the second then third smallest room and so until the result falls short of the maximum concentration.

Step 4

Dealing with the situations where the result exceeds the maximum concentration level.

Where the installation of a facility results in a concentration in excess of the maximum concentration level then it will be necessary to revise the system.

Please consult your Daikin supplier.

Step 5**Dealing with situations where the result exceeds the dangerous concentration level.**

Where the installation of a facility results in a concentration in excess of the dangerous concentration level then it may be necessary to revise the system design to some extent or else take one of the following courses of action.

Action 1: Making openings which will allow the air to flow freely into the room.

Make openings above and below the door which are each equivalent in size to 0.15% or more of the floor area or make a doorless opening.

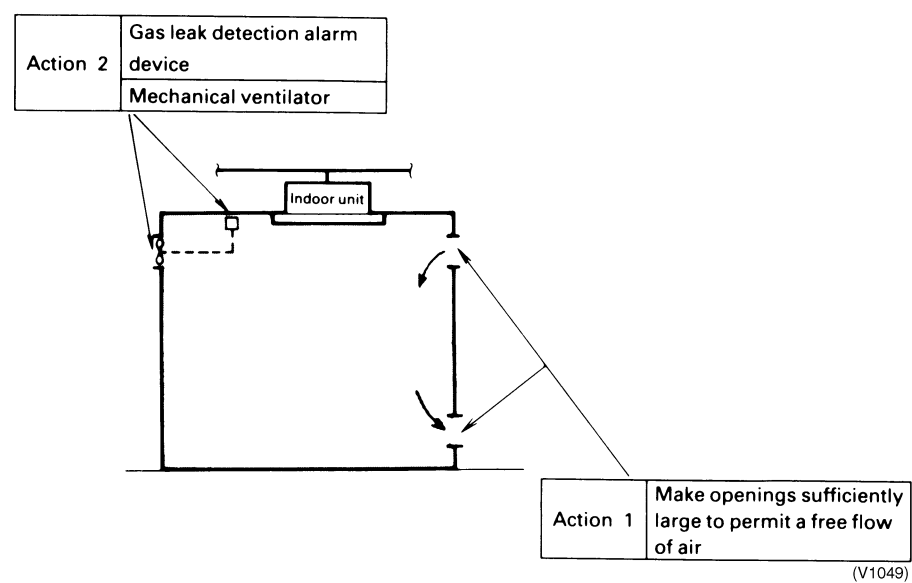
Action 2: Fit a mechanical ventilator linked to a gas leak detection alarm device.

6. Hand Over to Customer

6.1 Operational Steps

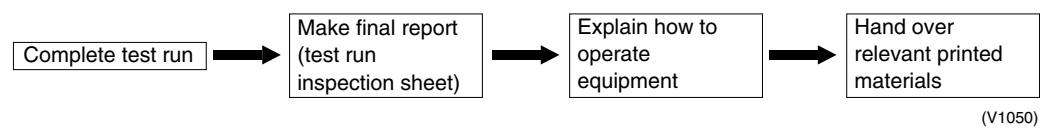

Important Points

- The measurements taken during the test run should be recorded and kept on a test run inspection sheet.
- Do not forget to record the **length of the refrigerant piping** and the **refrigerant additional charging volume** on the plate on the back of the outdoor unit external notice board, as this information will be required for servicing the system.
- Explain to the customer how to operate the equipment and let him try it.
- Assemble all the relevant diagrams and other printed matter which is required to operate the system and hand it all over to the customer (on the spot) and tell him to keep it.

List of equipment which has been delivered

Contract drawings

It is essential to prepare a control wiring diagram which clarifies the refrigerant system and the control system.

1 set of operation manuals

Names of those responsible for the work (emergency contact address)

Equipment guarantees.

(V1143)

- Make the service contact address clear.

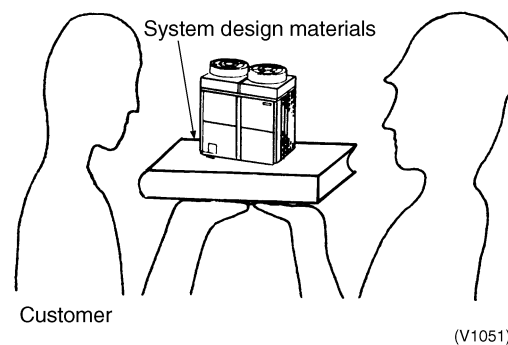

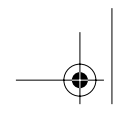

7. Appendix

7.1 Operating Noise of Indoor Units

7.1.1 Difference between Catalogue Data and Actual Noise

Operating noise differs depending on the place of measurement (room) because of the various degrees with which the room reverberates the sound. To determine the amount of reverberation under uniform conditions, the unit has been measured in a dead room with results having been compiled in the below table. The actual sound produced in unit operation can be determined from Table 1.

Sound pressure rise due to room reverberation (Higher than catalogue data)

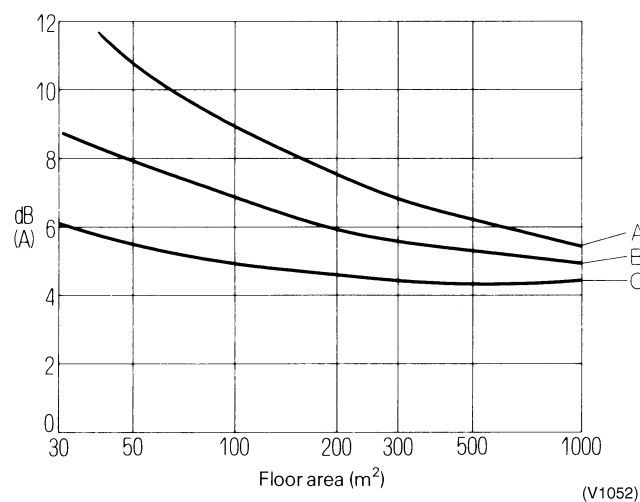

Table 1

	A	B	C	
Room Interior Detection	Floor	Mortar	Linoleum tile	Carpet
	Walls	Mortar	Plaster	Fiberglass + Saroncross finish
	Ceilin	Mortar	mineral wool tile	Fiberglass + Saroncross finish
Average Absorbed Sound (Room with Approx. 50 m ² Floor Area)	0.05	0.12	0.25	
Estimated value to be added to catalogue value	11~12	8~8.5	5~6	

Classifications of indoor unit environments (reference data)

Table 2

Classification	Environment	Example	Faint Noises (NOTE 2)	Recommended Operating Noise on Site
1	Non-active places requiring silence	Reception rooms, libraries, sitting rooms, hospitals (examining rooms) (NOTE 1)	~35	~40
2	Sedate business activities that do not disturb people even over time	Quiet offices, classrooms, small conference rooms, lobbies	~40	~45
3	Somewhat quiet settings that permit soft-spoken conversation, typical activities	Small offices, large conferences rooms, quiet stores, restaurants	~45	~50
4	Somewhat loud settings that permit regular conversation, brisk activity	Large offices, typical stores, cafeterias	~50	~55
5	Loud places that permit conversation in a loud voice, highly active place with many people	Loud large-side offices, large cafeterias, loud stores	~55	~60
6	Rather loud settings	Factories, gymnasiums, recreational places like pachinko parlors	~60	~65



- Notes:**
1. Excluding bedrooms
 2. Reference values of faint noises in the place of usage

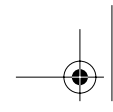

7.1.2 Faint Noises and Correcting Operating Noise with Respect to Faint Noises

Faint noises are defined as peripheral sounds existing while the unit is not running, which are picked up when measuring operating noise. If these faint noises are 10 dB or more than the noise produced by the unit, the measured value can be taken as the operating noise of the unit. But, the difference must be corrected if less than 10 dB, because of the effect these noises have on the actual measured value. Also, when the sound meter remains unchanged even while the unit is stopped, we can determine the operational noise to be at least 10 dB less than the faint noises, but we cannot pinpoint the operating noise exactly.

For example, if the faint noises are some 65 dB and the noise produced by the unit in operation is 70 dB, the indicated difference comes to 5 dB. Using Table 3, we recommend you correct the operating noise by about 2 dB to 68 dB.

Table 3 Correcting the effect of faint noises

	Unit: dB									
Difference between when noise is produced and when not	1	2	3	4	5	6	7	8	9	10
Corrective Value	-6.9	-4.4	-3.0	-2.3	-1.7	-1.25	-0.95	-0.75	-0.60	-0.45

7.1.3 Calculating Operating Noise

When two or more units are running at the same time, the amount of operating noise they produce rises. The total amount of noise produced can be obtained ahead of time with Chart 4.

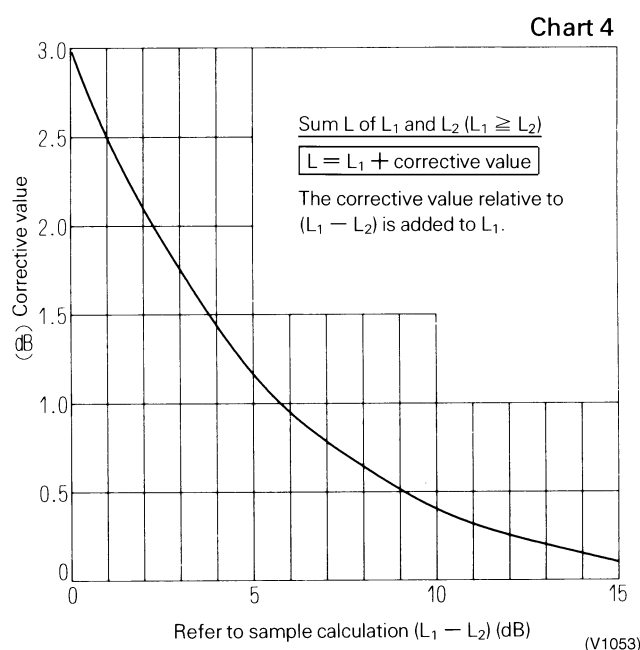

Sample calculation 1

L_1 and L_2 are given as compounded sounds of 50 and 49 dB respectively. Since $L_1 - L_2 = 50 - 49 = 1$, the corrective value is 2.5, therefore $50 + 2.5 = 52.5$ dB.

Sample calculation 2

When sounds of 40 dB, 38 dB, 37 dB and 40 dB are placed in order of magnitude, we obtain the following:

40 dB, 40 dB, 38 dB, 37 dB

To start, the difference between 40 dB and 40 dB is 0, therefore we take a corrective value of 3dB and obtain $40 + 3 = 43$ dB. The compounded sound of 43 dB and 38 dB has a 5.0 dB difference, thus a corrective value of 1.2 dB, which gives us 44.2 dB from $43 + 1.2$. In the same manner, the corrective value for 44.2 dB and 37 dB is approximately 0.7 dB, or in other words, $44.2 + 0.7 = 44.9$ dB.

7.2 Allowable Piping Length

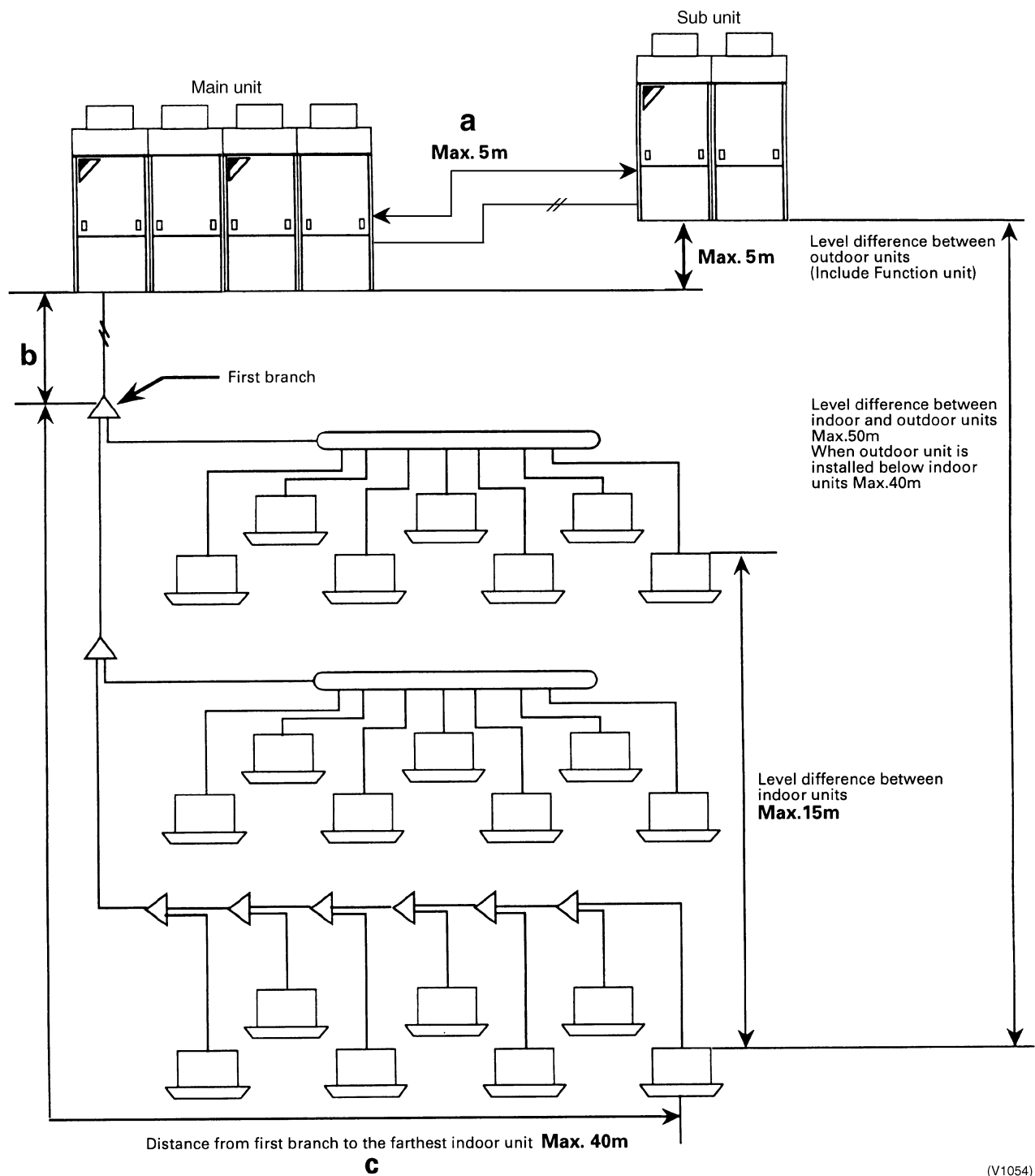

Points of piping design

1. $b + c = 100\text{m}$
2. Level difference between outdoor units (Main and Sub units) $a \leq 5\text{ m}$
3. Piping distance between first branch and the farthest indoor unit $\leq 40\text{ m}$
4. Level difference between indoor units $\leq 15\text{ m}$
5. Level difference between indoor and outdoor unit $\leq 50\text{ m}$
(Level difference is lower than 40 m when outdoor unit is installed below indoor unit.)
6. Refnet joint and header are not downstream for first installed Refnet header.

7.3 Selection of Refrigerant Pipe Size

Capacity of indoor unit and size of refrigerant pipe (G)

Class		20	25	32	40	50	63	80	100	125	200	250
Cooling Capacity (19.5 °CWB)	kcal/h	2,000	2,500	3,150	4,000	5,000	6,300	8,000	10,000	12,500	20,000	25,000
	Btu/h	7,900	9,900	12,500	15,900	19,900	25,000	31,800	39,700	49,600	79,000	99,000
	kW	2.3	2.9	3.7	4.7	5.8	7.3	9.3	11.6	14.5	23.0	28.8
Cooling Capacity (19 °CWB)	kW	2.2	2.8	3.6	4.5	5.6	7.1	9.0	11.2	14.0	22.4	28.0
Heating Capacity	kcal/h	2,200	2,800	3,400	4,300	5,400	6,900	8,600	10,800	13,800	21,500	27,000
	Btu/h	8,500	10,900	13,600	17,000	21,500	27,300	34,100	42,700	54,600	85,300	107,500
	kW	2.5	3.2	4.0	5.0	6.3	8.0	10.0	12.5	16.0	25.0	31.5
Liquid Pipes		φ6.4				φ9.5			φ9.5	φ12.7	φ12.7	
Gas Pipes		φ12.7				φ15.9			φ19.1	φ25.4	φ28.6	

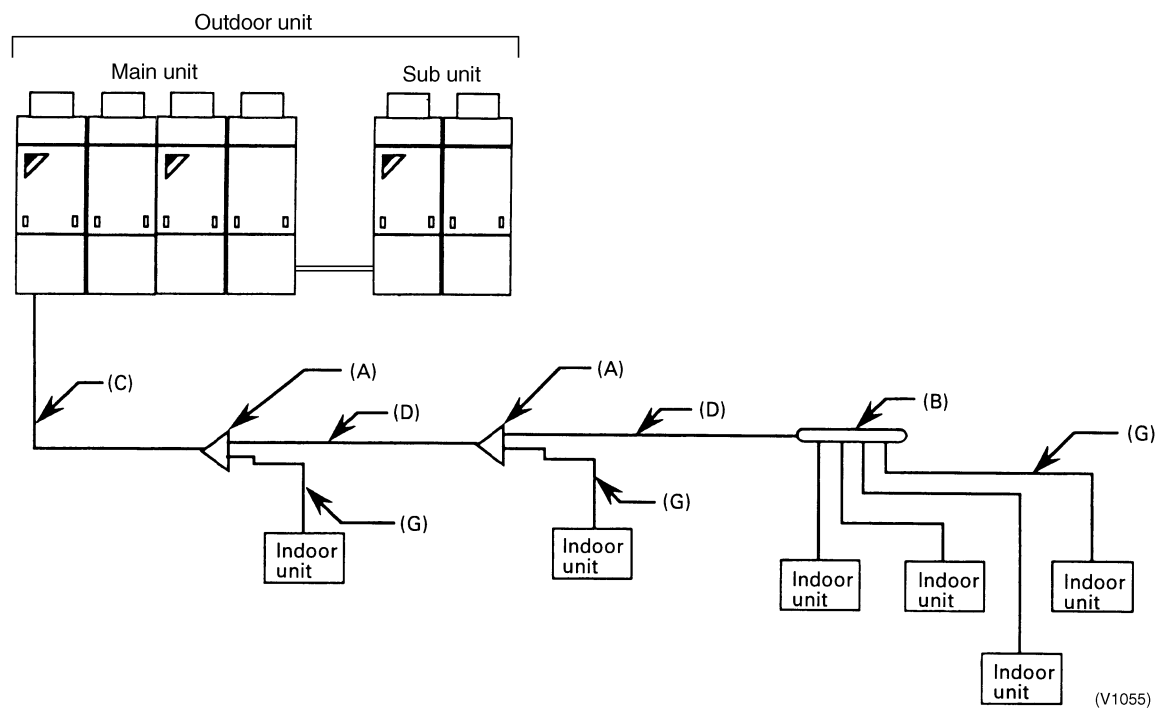

■ Selection of branch kit...REFNET joint (A) and REFNET beader (B)

Capacity	REFNET joint (A)	REFNET header (B)
Less than 100	KHRP26K11T	KHRP26K11H (Max. 4 branches)
100 or more to 160 (160 excluded)	KHRP26K18T	KHRP26K18H (Max. 6 branches)
160 or more to 330 (330 excluded)	KHRP26K37T	KHRP26K37H (Max. 8 branches)
330 or more to 640 (640 excluded)	KHRP26K40T + KHRP26K40TP ★Note 1	KHRP26K40H (Max. 8 branches) + KHRP26K40HP ★Note 1
640 or more	KHRP26K75T + KHRP26K75TP	★Note 2



- Note:**
1. KHRP26K40/75TP or KHRP26K40HP are pipe size reducer.
 2. For system with total capacity of 640 and over, connect REFNET header after the REFNET joint branch kit.

■ **Between outdoor unit and first branch kit (C)**

Applicable Model	Pipe Size (out. dia. × min. wall thickness)	
	Liquid Pipe	Gas Pipe (main)
RXYP16K	φ15.9 × t1.0	φ34.9 × t1.3
RXYP18~20K	φ19.1 × t1.0	φ34.9 × t1.3
RXYP24K	φ19.1 × t1.0	φ41.3 × t1.7
RXYP26~30K	φ22.2 × t1.2	φ41.3 × t1.7

■ **Between branches kit (D)**

Total Capacity Index of Indoor Unit after Branch	Pipe Size (out. dia. × min. wall thickness)	
	Liquid Pipe	Gas Pipe
Below 100	φ9.5 × t0.8	φ15.9 × t1.0
100 to below 160	φ9.5 × t0.8	φ19.1 × t1.0
160 to below 330	φ12.7 × t0.8	φ25.4 × t1.2
330 to below 480	φ15.9 × t1.0	φ34.9 × t1.3
480 to below 640	φ19.1 × t1.0	φ34.9 × t1.3
640 and over	φ19.1 × t1.0	φ41.3 × t1.7

7.4 Additional Charge of Refrigerant

Notes:

1. Refrigerant must be replenished for the R-407C VRV PLUS Series just as with past VRV Series.
2. If refrigerant is not replenished, the system will not operate properly.
3. For information on how to calculate the amount of refrigerant to be added, see next page.

Heat Pump System Example

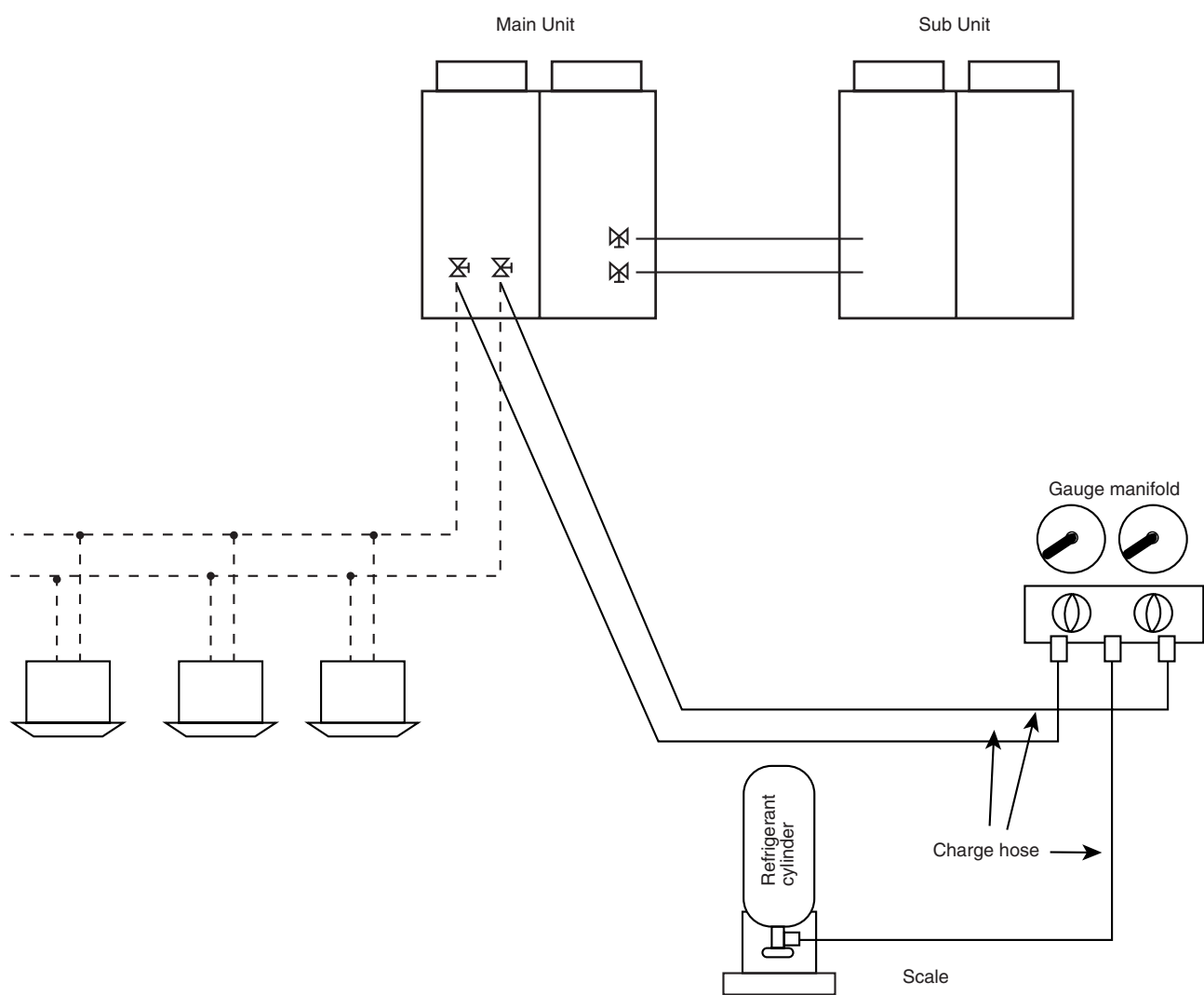

(V1056)

Work points

1. Select a level spot to place the scale.
2. Invert the refrigerant cylinder and refill in liquid state.
3. Be careful not to get frostbitten by refrigerant when purging air from the charge hose.
(About -50°C in atmosphere for R-407C)
4. Refill from liquid pipe and pressure equalizing pipe simultaneously.
5. You don't have to replenish refrigerant for each system. (You must check if the system need additional refrigerant charge before proceeding.)
6. Be sure to record the amount of refrigerant added on the label provided on the outdoor unit for that purpose as a reference for service or maintenance later on.

You must add refrigerant according to the length of piping in the field just as with previous VRV Series. It may be convenient to record the length of the piping after installation on the outdoor unit's label. When you are finished vacuuming the system, add refrigerant before opening the outdoor unit's stop valve. Amount of refrigerant is calculated according to the length of the liquid pipe.



Table 1: Additional refrigerant per meter of piping (liquid pipe)

Piping Size (φ)	Refrigerant Amount (kg)
22.2	0.39
19.1	0.28
15.9	0.19
12.7	0.12
9.5	0.06
6.4	0.023

7.4.1 Precautions in Charging Refrigerant

Mark the Model Number of the Indoor Unit and Its Location.

This information is needed for aftercare service.

Indoor unit model number	1	2	3	4	5	6	7	8
Location								
Indoor unit model number	9	10	11	12	13	14	15	16
Location								
Indoor unit model number	17	18	19	20	21	22	23	24
Location								
Indoor unit model number	25	26	27	28	29	30	31	32
Location								



Calculating Refrigerant Charge

- Calculate the charge of refrigerant needed as described below, and add accordingly.
- Record your calculations for use by aftercare service.

Total length of liquid line piping (φ 22.2)	+	Total length of liquid line piping (φ 19.1)
+		Total length of liquid line piping (φ 12.7)
+		Total length of liquid line piping (φ 6.4)

+ { 0 :RSXYP16,18,24,28
0.4:RSXYP30
0.6:RSXYP26
0.8:RSXYP20

(V1144)

Example of refrigerant branch using REFNET joint for RSXYP28

(V1057)

a : φ 22.2 × 10m	i : φ 6.4 × 5m
b : φ 22.2 × 2m	j : φ 6.4 × 5m
c : φ 22.2 × 5m	k : φ 6.4 × 5m
d : φ 19.5 × 5m	l : φ 9.5 × 5m
e : φ 15.9 × 5m	m : φ 6.4 × 5m
f : φ 12.7 × 5m	n : φ 6.4 × 5m
g : φ 9.5 × 5m	p : φ 6.4 × 5m
h : φ 9.5 × 5m	

$$R = \begin{matrix} \uparrow & \uparrow & \uparrow & \uparrow \\ 17 \times 0.39 & + & 5 \times 0.28 & + & 5 \times 0.19 & + & 5 \times 0.12 \\ \downarrow & & \downarrow & & \downarrow & & \downarrow \\ a+b+c & & d & & e & & f \\ + & + & + & + & + & + & + \\ 15 \times 0.06 & + & 30 \times 0.023 & + & 0 & + & 0 \\ \downarrow & & \downarrow & & \downarrow & & \downarrow \\ g+h+l & & i+j+k+m+n+p & & & & \\ = & 6.63 & + & 1.4 & + & 0.95 & + & 0.6 & + & 0.9 & + & 0.69 & + & 0 & = & 11.17\text{kg} \\ & & & & & & & & & & & & & & & \downarrow \\ & & & & & & & & & & & & & & & \boxed{11.2\text{kg}} \end{matrix} \quad (V1145)$$

Example of refrigerant branch using REFNET joint and REFNET header for RSXYP28

(V1058)

a : φ 22.2 × 30m	g : φ 6.4 × 10m
b : φ 15.9 × 10m	h : φ 6.4 × 20m
c : φ 9.5 × 10m	i : φ 12.7 × 10m
d : φ 9.5 × 10m	j : φ 6.4 × 10m
e : φ 9.5 × 10m	k : φ 6.4 × 9m
f : φ 9.5 × 10m	

$$R = \begin{matrix} \uparrow & \uparrow & \uparrow \\ 30 \times 0.39 & + & 10 \times 0.19 & + & 10 \times 0.12 \\ \downarrow & & \downarrow & & \downarrow \\ a & & b & & i \\ + & + & + & + & + \\ 40 \times 0.06 & + & 49 \times 0.023 & + & 0 \\ \downarrow & & \downarrow & & \downarrow \\ c+d+e+f & & g+h+j+k & & \\ = & 18.32 & & & \\ & & & & \downarrow \\ & & & & \boxed{18.3\text{kg}} \end{matrix} \quad (V1157)$$

Example of refrigerant branch using REFNET header for RSXYP28

(V1059)

a : φ 22.2 × 20m	f : φ 6.4 × 23m
b : φ 9.5 × 10m	g : φ 6.4 × 20m
c : φ 9.5 × 10m	h : φ 6.4 × 20m
d : φ 6.4 × 20m	i : φ 6.4 × 30m
e : φ 6.4 × 10m	

$$R = \begin{matrix} \uparrow & \uparrow & \uparrow \\ 20 \times 0.39 & + & 20 \times 0.06 & + & 123 \times 0.023 \\ \downarrow & & \downarrow & & \downarrow \\ a & & b+c & & d+e+f+g+h+i \\ = & 7.8 & + & 1.2 & + & 2.83 & = & 11.83 \\ & & & & & & & \downarrow \\ & & & & & & & \boxed{11.8\text{kg}} \end{matrix} \quad (V1146)$$

Full Refrigerant Recharging

The amount of refrigerant needed to completely recharge the system equals to that of the refrigerant charge at factory set (marked on name plate) plus the above additional charge.

Extracting Refrigerant

Open the stop valves on both the gas line and liquid line, and extract the refrigerant from the service ports.

General Information

99

Все каталоги и инструкции здесь: <https://splitsystema48.ru/instrukcii-po-ekspluatatsii-kondicionerov.html>

7.5 REFNET Pipe Connections for VRV R-407C PLUS Series

7.5.1 REFNET JOINT (for Cooling Only and Heat Pump System)

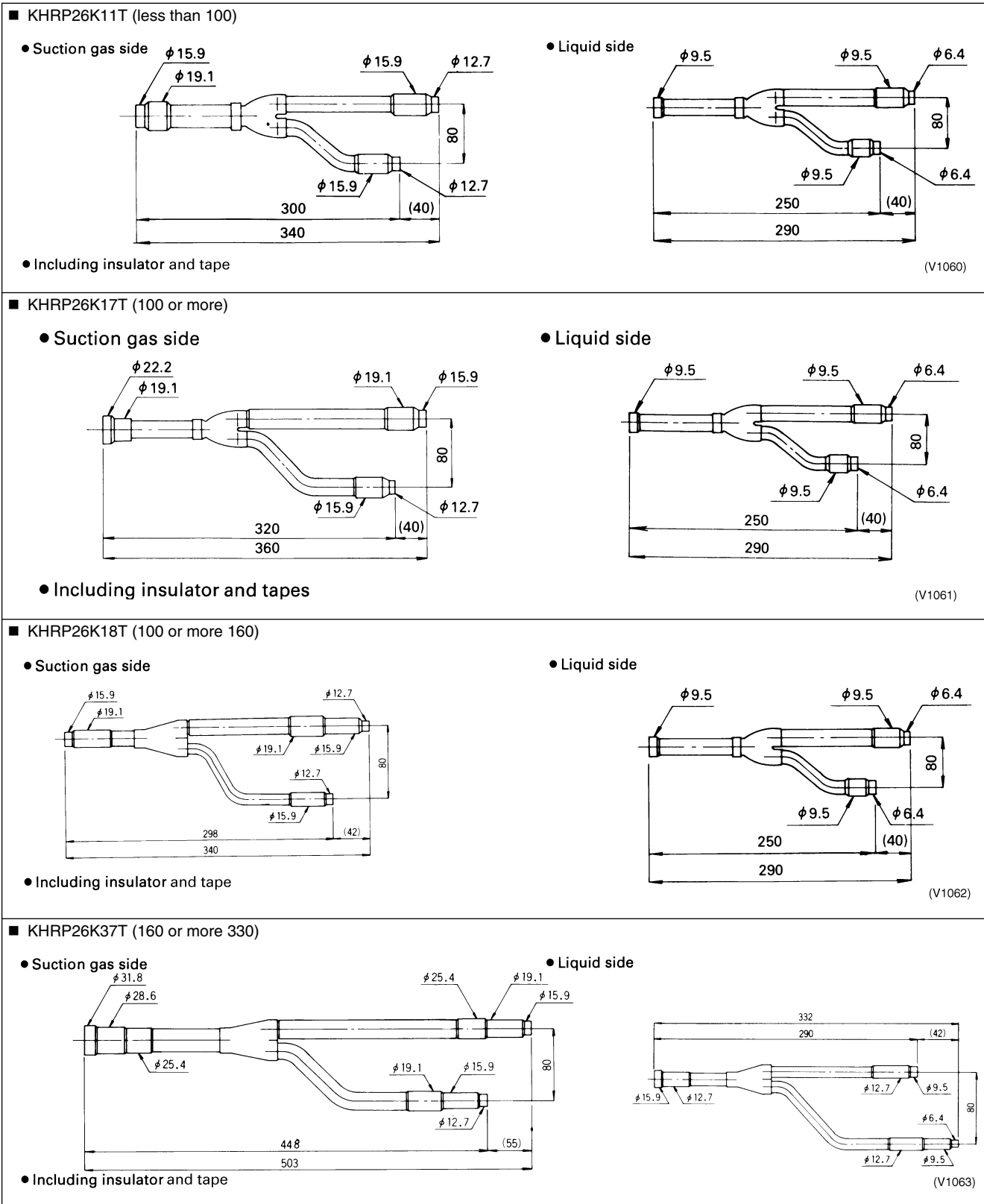

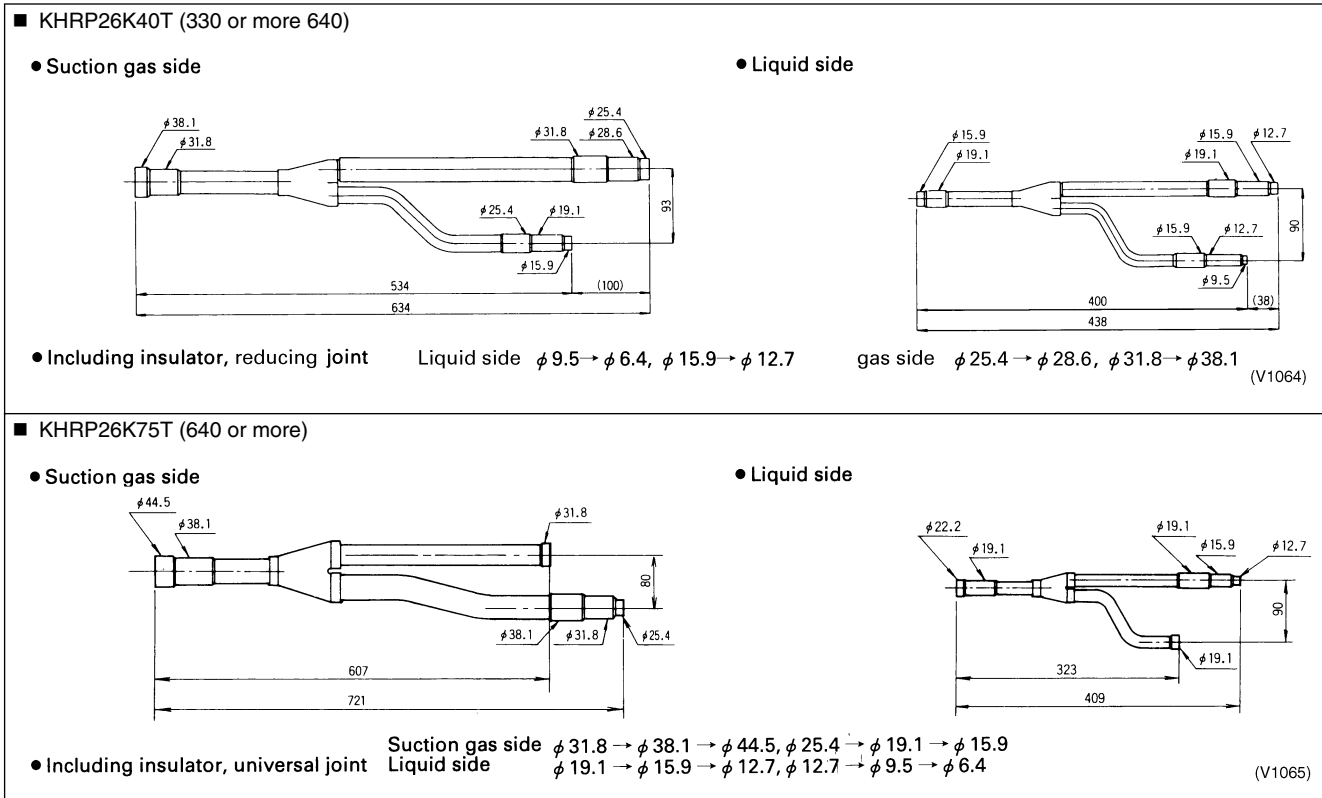

7.5.2 REFNET HEADER (for Cooling Only and Heat Pump System)

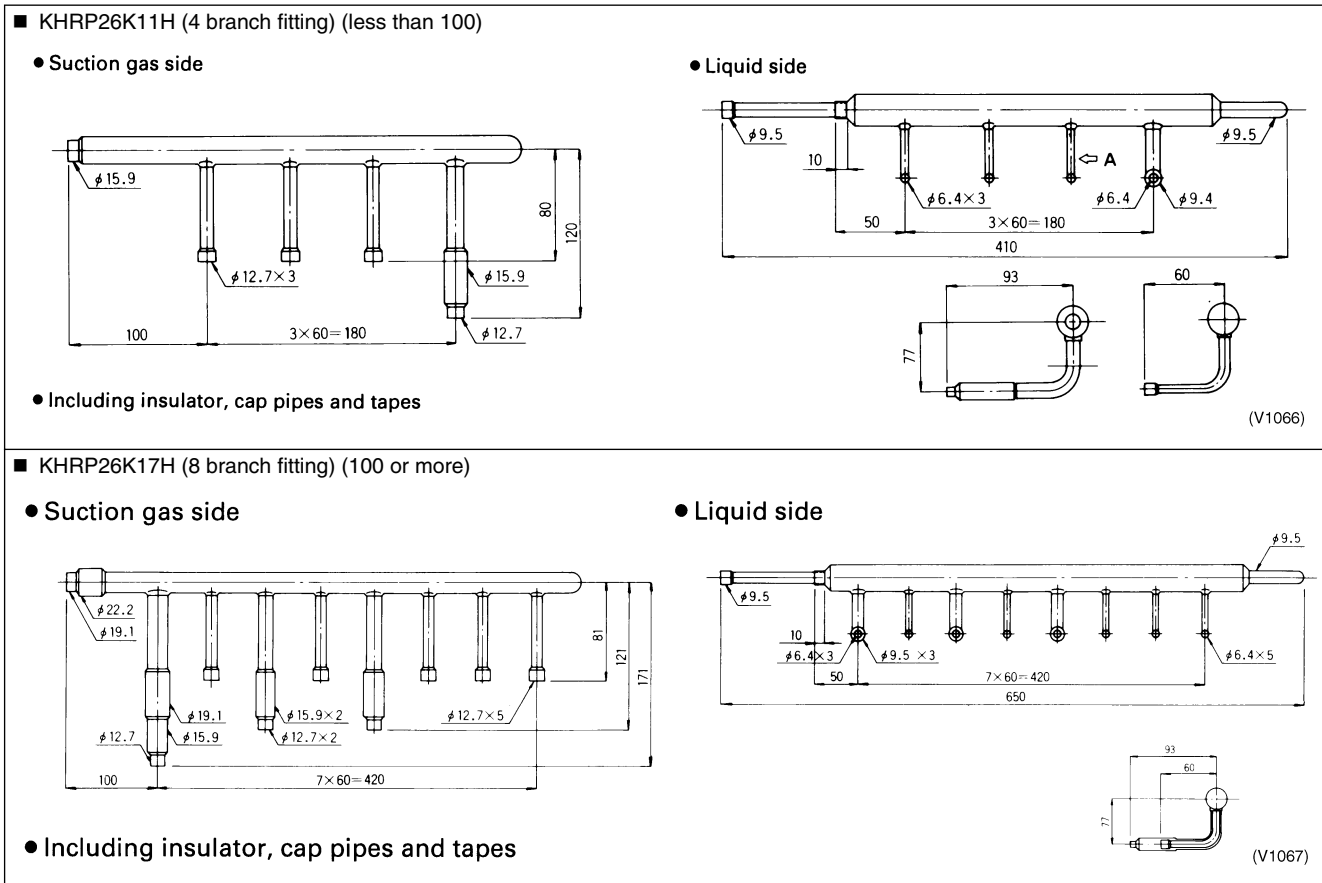

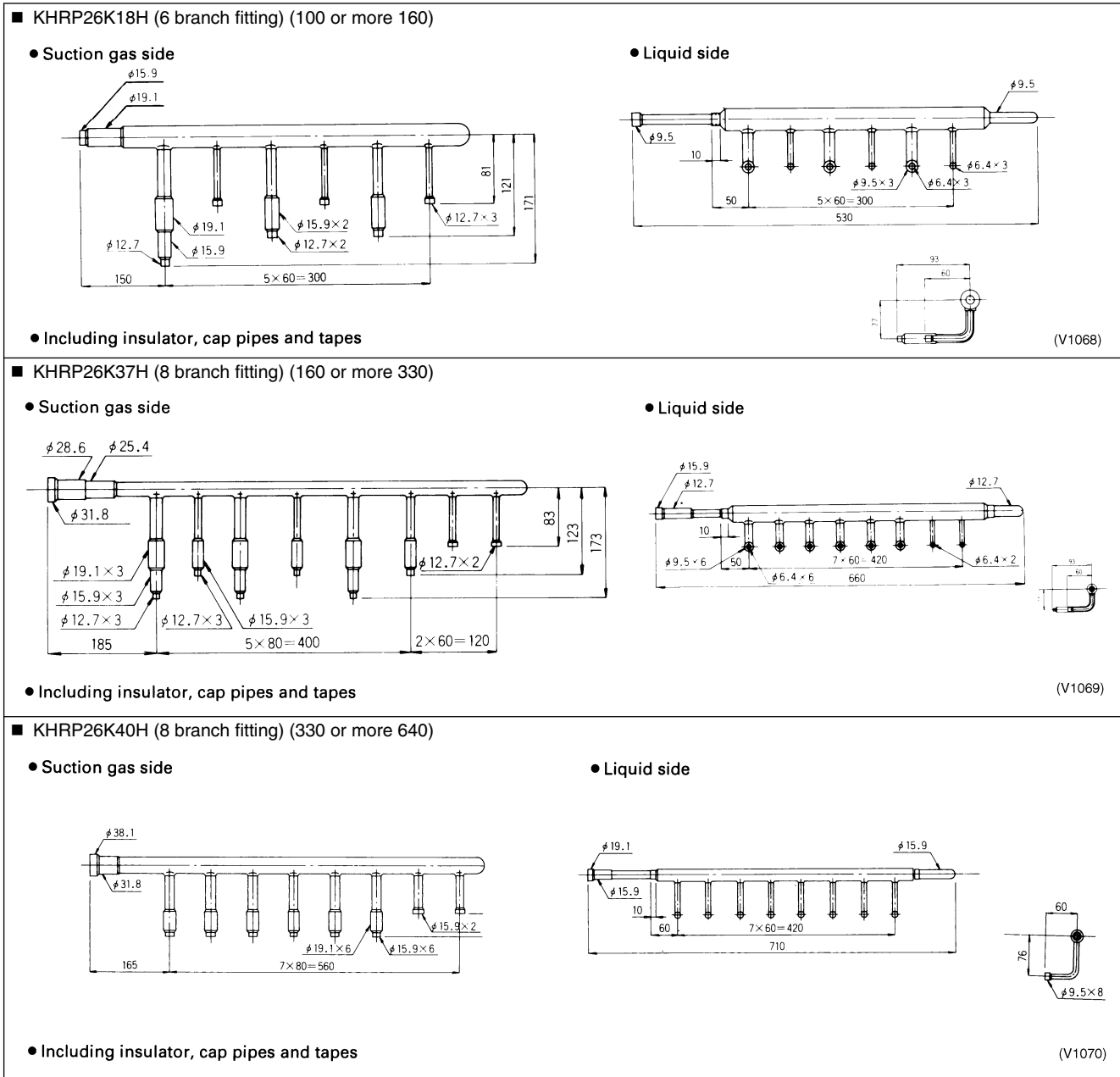

7.5.3 PIPE SIZE REDUCER (For R-407C)

■ This kit including followings;

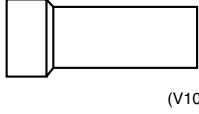
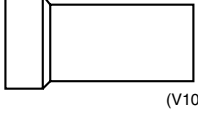
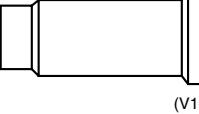
Name	Pipe size reducer (1)	Pipe size reducer (2)	Pipe size reducer (3)
Figure			
Q'ty	KHRP26K40TP	1	—
	KHRP26K40HP	—	1
	KHRP26K75TP	1	1

■ This kits are pipe size reducers for REFNET JOINT and HEADER and applicable to following REFNET CONNECTOR.

Kit Name	REFNET CONNECTOR
KHRP26K40TP	KHRP26K40T (Gas pipe)
KHRP26K40HP	KHRP26K40H (Gas pipe)
KHRP26K75TP	KHRP26K75T (Gas pipe)

The figure and size of pipe size reducers are as followings;

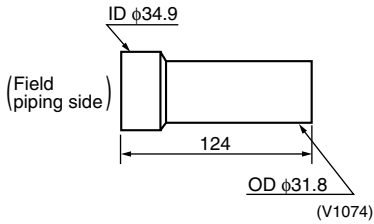
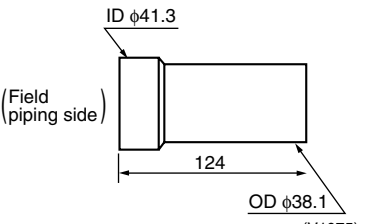
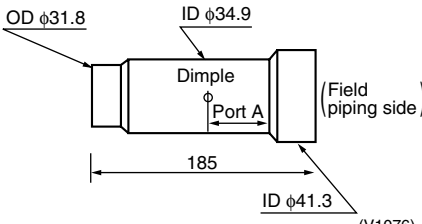
Pipe size reducer (1)	Pipe size reducer (2)	Pipe size reducer (3)
		
		★ For φ34.9, cut the center of the part A.

1. Select the field piping size according to the installation manual of the BRANCH PIPING KIT.
2. Connect the PIPE SIZE REDUCER suitable for the field piping size to the branch piping kit.
ex.) Connect the reducers to the branch piping kit, KHRP26K75T. For inlet piping size is φ41.3 and outlet 1-2 piping size are φ34.9.

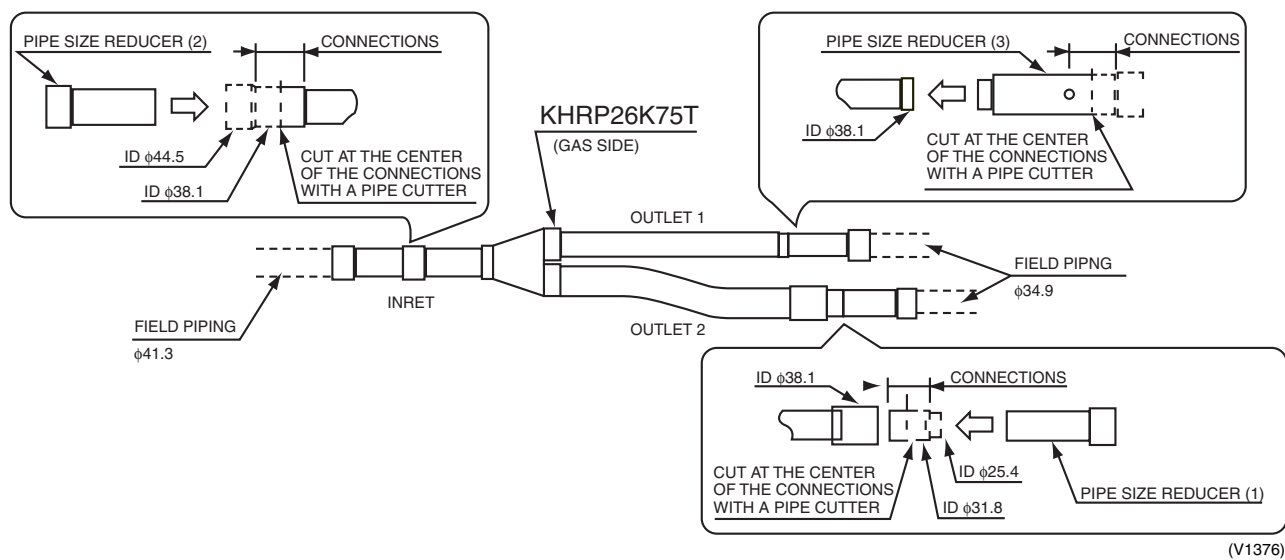

7.5.4 Piping Kits for Side and Bottom Piping – Outdoor Unit

Piping kit for side piping KHF30A30L

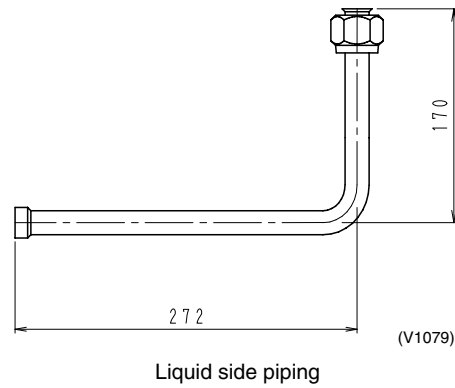
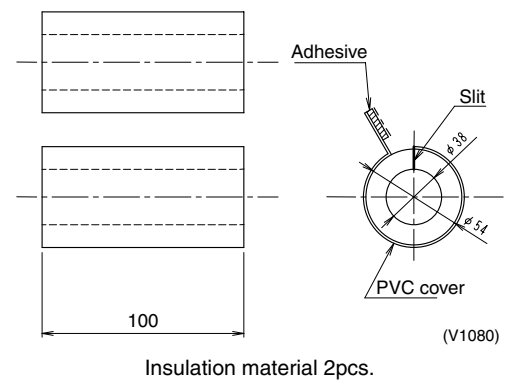
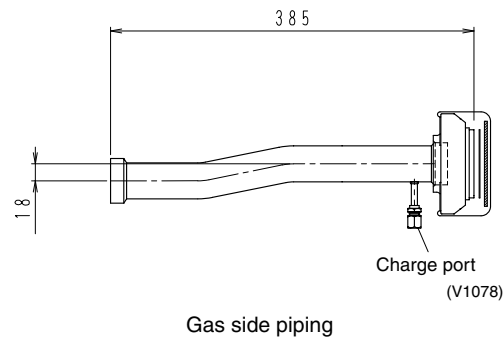

Piping kit for bottom piping KHF30A30U

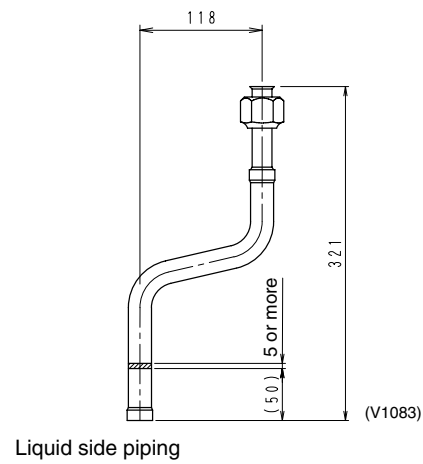
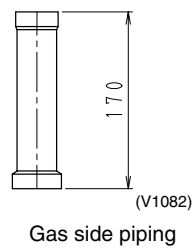
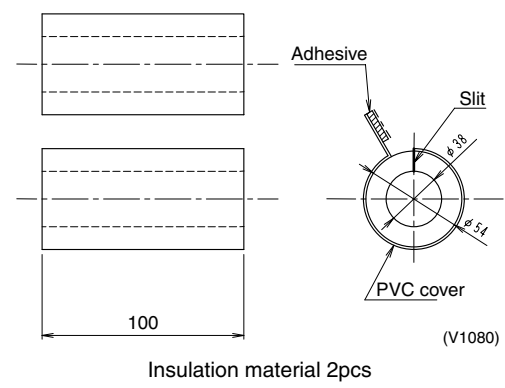
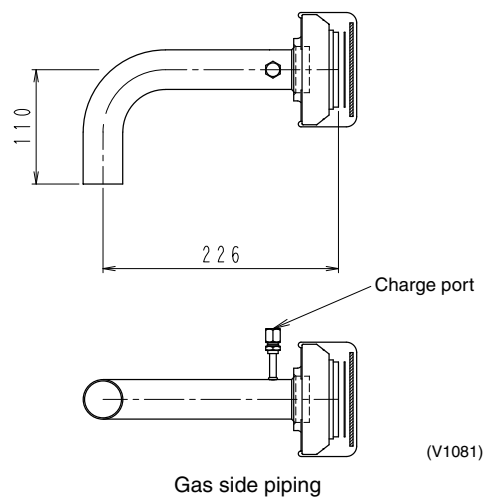

REFNET Joint and Header Installation

1. REFNET joint
(Gas line and liquid line branch pipe)

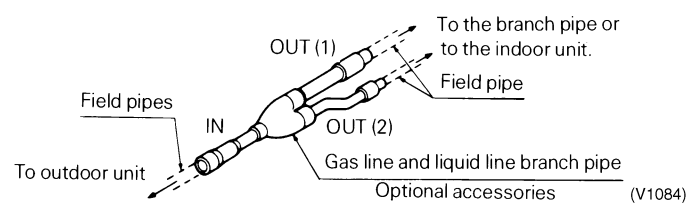

- If the selected building pipe differs from the branch pipe in size, cut the connection with a pipe cutter as shown below.

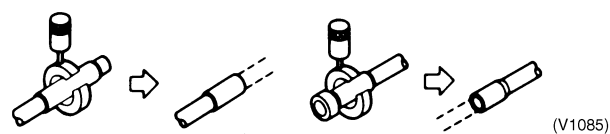

- Install the branch pipe either vertically or horizontally.

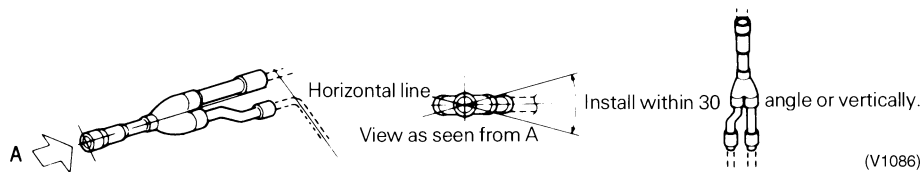

- Insulate the branch pipe as described in the kit installation manual.

2. REFNET header

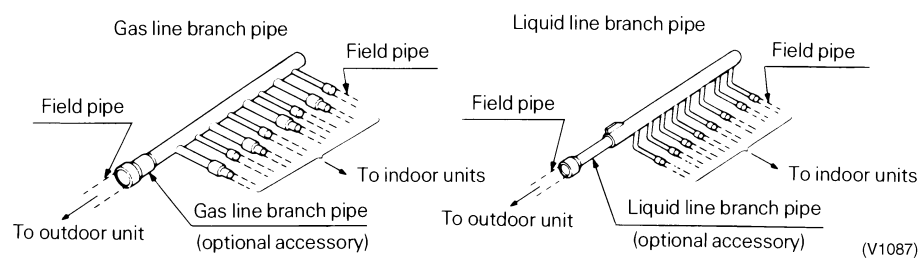

- If the selected field pipe differs from the branch pipe in size, cut the connection with a pipe cutter as shown below.

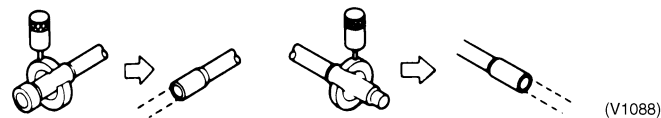

- Fit a stop end on all open branch pipe connections not in use.

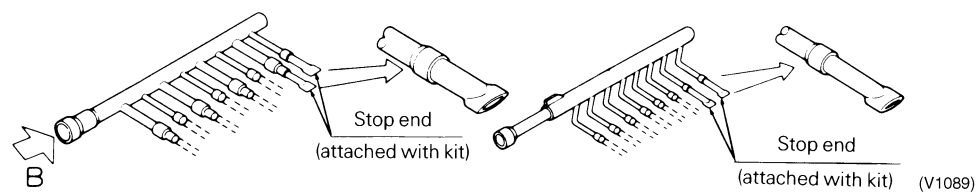

- Install the branch pipe horizontally.

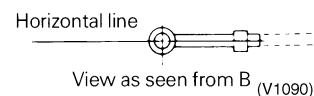

- Insulate the branch pipe as described in the kit installation manual.



Note:

- Install the REFNET joint horizontally or vertically, keeping it within a 30° angle when installed horizontally.
- Install the REFNET header so that it branches horizontally.
- Do not use a T-joint for the branch pipe.

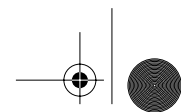

7.6 VRV Inspection Sheet

Inspection date: _____

Delivery date: _____

Transfer date: _____

Owner		System name	
-------	--	-------------	--

Outdoor units

	Installation location	Model	Unit No.
Outdoor unit			
Main unit			
Sub unit			

Indoor units

No.	Installation	Model	Unit No.	Group No.	No.	Installation	Model	Unit No.	Group No.
1					17				
2					18				
3					19				
4					20				
5					21				
6					22				
7					23				
8					24				
9					25				
10					26				
11					27				
12					28				
13					29				
14					30				
15					31				
16					32				

Field settings

C/H SELECT (setting mode 1)			C/H SELECT setting (SS1)			Low noise operation			Sequential start	
IND	MASTER	SLAVE	IN/D	OUT/D		ON	OFF	ON	OFF	
Tc			Te			Defrost SETTING			Refrigerant addition/replenishment	
H	M	L	H	M	L	H	M	L	kg	

Company name _____ Inspector _____

(V1091)





Before turning on the power

System name

	Inspection item	Inspection method	Standard (guideline)	Measurement values				Decision							
				G	NG										
	Breaker capacity	Visual inspection	Specified capacity	G	NG										
Main unit	Refrigerant piping system	Gas detector	No leaks	G	NG										
	Heat exchanger	Visual inspection	No clogging or damage	G	NG										
	Terminal connection section	Screwdriver, etc.	No looseness	G	NG										
	Fan motor electrical insulation	500-V megatester	1 MΩ or more					MΩ							
	Compressor electrical insulation	500-V megatester	1 MΩ or more	INV	MΩ	STD1	MΩ	STD2	MΩ						
	Installation	Visual inspection	Short circuit, etc.		G	NG									
Sub unit	Refrigerant piping system	Gas detector	No leaks	G	NG										
	Heat exchanger	Visual inspection	No clogging or damage	G	NG										
	Terminal connection section	Screwdriver, etc.	No looseness	G	NG										
	Fan motor electrical insulation	500-V megatester	1 MΩ or more					MΩ							
	Installation	Visual inspection	Short circuit, etc.		G	NG									
	Indoor unit	Refrigerant system	Gas detector	No leaks	Room 1	G	NG	Room 2	G	NG	Room 3	G	NG	Room 4	G
Room 5					G	NG	Room 6	G	NG	Room 7	G	NG	Room 8	G	NG
Room 9					G	NG	Room 10	G	NG	Room 11	G	NG	Room 12	G	NG
Room 13					G	NG	Room 14	G	NG	Room 15	G	NG	Room 16	G	NG
Room 17					G	NG	Room 18	G	NG	Room 19	G	NG	Room 20	G	NG
Room 21					G	NG	Room 22	G	NG	Room 23	G	NG	Room 24	G	NG
Room 25					G	NG	Room 26	G	NG	Room 27	G	NG	Room 28	G	NG
Room 29					G	NG	Room 30	G	NG	Room 31	G	NG	Room 32	G	NG
Air filter		Visual inspection	No clogging or damage	Room 1	G	NG	Room 2	G	NG	Room 3	G	NG	Room 4	G	NG
				Room 5	G	NG	Room 6	G	NG	Room 7	G	NG	Room 8	G	NG
				Room 9	G	NG	Room 10	G	NG	Room 11	G	NG	Room 12	G	NG
				Room 13	G	NG	Room 14	G	NG	Room 15	G	NG	Room 16	G	NG
				Room 17	G	NG	Room 18	G	NG	Room 19	G	NG	Room 20	G	NG
				Room 21	G	NG	Room 22	G	NG	Room 23	G	NG	Room 24	G	NG
				Room 25	G	NG	Room 26	G	NG	Room 27	G	NG	Room 28	G	NG
				Room 29	G	NG	Room 30	G	NG	Room 31	G	NG	Room 32	G	NG
Heat exchanger		Visual inspection	No clogging or damage	Room 1	G	NG	Room 2	G	NG	Room 3	G	NG	Room 4	G	NG
				Room 5	G	NG	Room 6	G	NG	Room 7	G	NG	Room 8	G	NG
				Room 9	G	NG	Room 10	G	NG	Room 11	G	NG	Room 12	G	NG
				Room 13	G	NG	Room 14	G	NG	Room 15	G	NG	Room 16	G	NG
				Room 17	G	NG	Room 18	G	NG	Room 19	G	NG	Room 20	G	NG
				Room 21	G	NG	Room 22	G	NG	Room 23	G	NG	Room 24	G	NG
				Room 25	G	NG	Room 26	G	NG	Room 27	G	NG	Room 28	G	NG
				Room 29	G	NG	Room 30	G	NG	Room 31	G	NG	Room 32	G	NG
Fan motor electrical insulation	500-V megatester	1 MΩ or more	Room 1	MΩ	Room 2	MΩ	Room 3	MΩ	Room 4	MΩ					
			Room 5	MΩ	Room 6	MΩ	Room 7	MΩ	Room 8	MΩ					
			Room 9	MΩ	Room 10	MΩ	Room 11	MΩ	Room 12	MΩ					
			Room 13	MΩ	Room 14	MΩ	Room 15	MΩ	Room 16	MΩ					
			Room 17	MΩ	Room 18	MΩ	Room 19	MΩ	Room 20	MΩ					
			Room 21	MΩ	Room 22	MΩ	Room 23	MΩ	Room 24	MΩ					
			Room 25	MΩ	Room 26	MΩ	Room 27	MΩ	Room 28	MΩ					
			Room 29	MΩ	Room 30	MΩ	Room 31	MΩ	Room 32	MΩ					
Auxiliary heater electrical insulation	500-V megatester	1 MΩ or more	Room 1	MΩ	Room 2	MΩ	Room 3	MΩ	Room 4	MΩ					
			Room 5	MΩ	Room 6	MΩ	Room 7	MΩ	Room 8	MΩ					
			Room 9	MΩ	Room 10	MΩ	Room 11	MΩ	Room 12	MΩ					
			Room 13	MΩ	Room 14	MΩ	Room 15	MΩ	Room 16	MΩ					
			Room 17	MΩ	Room 18	MΩ	Room 19	MΩ	Room 20	MΩ					
			Room 21	MΩ	Room 22	MΩ	Room 23	MΩ	Room 24	MΩ					
			Room 25	MΩ	Room 26	MΩ	Room 27	MΩ	Room 28	MΩ					
			Room 29	MΩ	Room 30	MΩ	Room 31	MΩ	Room 32	MΩ					
Installation	Visual inspection	Short circuit, etc.	Room 1	G	NG	Room 2	G	NG	Room 3	G	NG	Room 4	G	NG	
			Room 5	G	NG	Room 6	G	NG	Room 7	G	NG	Room 8	G	NG	
			Room 9	G	NG	Room 10	G	NG	Room 11	G	NG	Room 12	G	NG	
			Room 13	G	NG	Room 14	G	NG	Room 15	G	NG	Room 16	G	NG	
			Room 17	G	NG	Room 18	G	NG	Room 19	G	NG	Room 20	G	NG	
			Room 21	G	NG	Room 22	G	NG	Room 23	G	NG	Room 24	G	NG	
			Room 25	G	NG	Room 26	G	NG	Room 27	G	NG	Room 28	G	NG	
			Room 29	G	NG	Room 30	G	NG	Room 31	G	NG	Room 32	G	NG	

(V1092)

During operation

System name

	Inspection item	Inspection method	Standard (guideline)	Measurement values				Decision		
				R-S	V	S-T	V		R-T	V
Main unit	Main power supply voltage	Tester	Rated voltage $\pm 10\%$	R-S	V	S-T	V	R-T	V	
	Operation circuit voltage	Tester	Rated voltage $\pm 10\%$						V	
	Fan rotation direction	Visual inspection	Forward rotation			G		NG		
	Fan noise/vibration	Listening	No noise or vibration							
	Fan operation current	Clamp meter				M1(11)F, M2(12)F, A	M21F, M22F A			
	Suction air temperature	Thermometer	Temperature differential							$^{\circ}\text{C}$
	Discharge air temperature	Thermometer	9-11 $^{\circ}\text{C}$ when cooling, 2-3.5 $^{\circ}\text{C}$ when heating							$^{\circ}\text{C}$
	Compressor discharge pressure	Pressure gauge				INV				Mpa
						STD1				Mpa
						STD2				Mpa
	Compressor suction pressure	Pressure gauge								Mpa
	Compressor operating current	Clamp meter	Phase differential within 1A			INV				A
						STD1	R()A, S()A, T()A			
						STD2	R()A, S()A, T()A			
	Compressor operating frequency	Clamp meter				INV				Hz
Suction pipe temperature	Thermometer	3-15 $^{\circ}\text{C}$			INV	$^{\circ}\text{C}$	STD1	$^{\circ}\text{C}$	STD2	$^{\circ}\text{C}$
Discharge pipe temperature	Thermometer	85-105 $^{\circ}\text{C}$			INV	$^{\circ}\text{C}$	STD1	$^{\circ}\text{C}$	STD2	$^{\circ}\text{C}$
Clank case heater	Touch	Warm			INV				G·NG	
					STD1				G·NG	
					STD2				G·NG	
Sub unit	Fan rotation direction	Visual inspection	Forward rotation			G		NG		
	Fan noise/vibration	Listening	No noise or vibration							
	Fan operating current	Clamp meter							A	
	Suction air temperature	Thermometer	Temperature differential							$^{\circ}\text{C}$
	Discharge air temperature	Thermometer	9-11 $^{\circ}\text{C}$ when cooling, 2-3.5 $^{\circ}\text{C}$ when heating							$^{\circ}\text{C}$

(V1093)

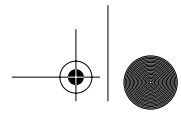

During operation

System name

	Inspection item	Inspection method	Standard (guideline)	Measurement values				Decision				
				Room 1	Room 2	Room 3	Room 4					
Indoor unit	Power supply voltage	Tester	Rated voltage ±10%	Room 1	V	Room 2	V	Room 3	V	Room 4	V	
				Room 5	V	Room 6	V	Room 7	V	Room 8	V	
				Room 9	V	Room10	V	Room11	V	Room12	V	
				Room13	V	Room14	V	Room15	V	Room16	V	
				Room17	V	Room18	V	Room19	V	Room20	V	
				Room21	V	Room22	V	Room23	V	Room24	V	
				Room25	V	Room26	V	Room27	V	Room28	V	
				Room29	V	Room30	V	Room31	V	Room32	V	
	Suction air temperature	Thermometer	Temperature differential	Room 1	°C	Room 2	°C	Room 3	°C	Room 4	°C	
				Room 5	°C	Room 6	°C	Room 7	°C	Room 8	°C	
				Room 9	°C	Room10	°C	Room11	°C	Room12	°C	
				Room13	°C	Room14	°C	Room15	°C	Room16	°C	
				Room17	°C	Room18	°C	Room19	°C	Room20	°C	
				Room21	°C	Room22	°C	Room23	°C	Room24	°C	
				Room25	°C	Room26	°C	Room27	°C	Room28	°C	
				Room29	°C	Room30	°C	Room31	°C	Room32	°C	
	Discharge air temperature	Thermometer	9~13°C when cooling, 15~20°C when heating	Room 1	°C	Room 2	°C	Room 3	°C	Room 4	°C	
				Room 5	°C	Room 6	°C	Room 7	°C	Room 8	°C	
				Room 9	°C	Room10	°C	Room11	°C	Room12	°C	
				Room13	°C	Room14	°C	Room15	°C	Room16	°C	
				Room17	°C	Room18	°C	Room19	°C	Room20	°C	
				Room21	°C	Room22	°C	Room23	°C	Room24	°C	
				Room25	°C	Room26	°C	Room27	°C	Room28	°C	
				Room29	°C	Room30	°C	Room31	°C	Room32	°C	
	Fan rotation direction	Visual inspection	Forward rotation	Room 1	G NG	Room 2	G NG	Room 3	G NG	Room 4	G NG	
				Room 5	G NG	Room 6	G NG	Room 7	G NG	Room 8	G NG	
				Room 9	G NG	Room10	G NG	Room11	G NG	Room12	G NG	
				Room13	G NG	Room14	G NG	Room15	G NG	Room16	G NG	
				Room17	G NG	Room18	G NG	Room19	G NG	Room20	G NG	
				Room21	G NG	Room22	G NG	Room23	G NG	Room24	G NG	
				Room25	G NG	Room26	G NG	Room27	G NG	Room28	G NG	
				Room29	G NG	Room30	G NG	Room31	G NG	Room32	G NG	
Fan noise / vibration	Listening	No noise or vibration	Room 1	G NG	Room 2	G NG	Room 3	G NG	Room 4	G NG		
			Room 5	G NG	Room 6	G NG	Room 7	G NG	Room 8	G NG		
			Room 9	G NG	Room10	G NG	Room11	G NG	Room12	G NG		
			Room13	G NG	Room14	G NG	Room15	G NG	Room16	G NG		
			Room17	G NG	Room18	G NG	Room19	G NG	Room20	G NG		
			Room21	G NG	Room22	G NG	Room23	G NG	Room24	G NG		
			Room25	G NG	Room26	G NG	Room27	G NG	Room28	G NG		
			Room29	G NG	Room30	G NG	Room31	G NG	Room32	G NG		
Fan operating current	Clamp meter		Room 1	A	Room 2	A	Room 3	A	Room 4	A		
			Room 5	A	Room 6	A	Room 7	A	Room 8	A		
			Room 9	A	Room10	A	Room11	A	Room12	A		
			Room13	A	Room14	A	Room15	A	Room16	A		
			Room17	A	Room18	A	Room19	A	Room20	A		
			Room21	A	Room22	A	Room23	A	Room24	A		
			Room25	A	Room26	A	Room27	A	Room28	A		
			Room29	A	Room30	A	Room31	A	Room32	A		

(V1094)

7.7 Piping System Diagrams

7.7.1 Indoor Unit

FXYCP, FXYFP, FXYKP, FXYSP, FXYMP, FXYHP, FXYAP, FXYLP, FXYLMP

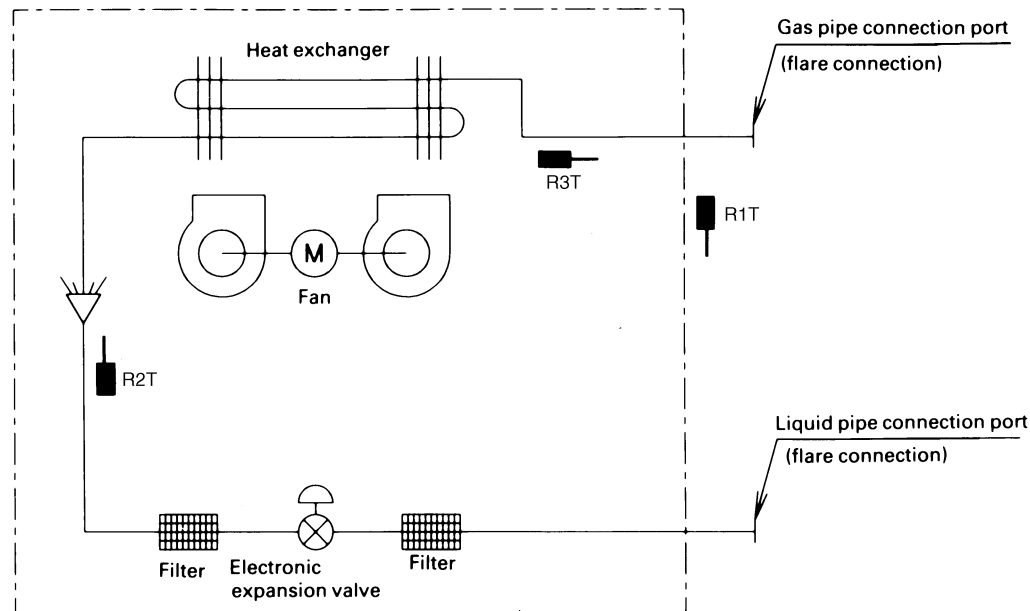

R1T: Thermister for suction air temp.
 R2T: Thermister for liquid line temp.
 R3T: Thermister for gas line temp.

■ Refrigerant pipe connection port diameters

Model	(mm)	
	Gas	Liquid
FXYCP20K/25K/32K/40K FXYFP32K/40K FXYKP25K/32K/40K FXYSP20K/25K/32K/40K FXYMP40K/50K FXYHP32K FXYAP25K/32K/40K FXYLP25K/40K FXYLMP25K/40K	φ12.7	φ6.4
FXYCP50K/63K/80K FXYFP50K/63K/80K FXYKP63K FXYSP50K/63K/80K FXYMP63K/80K/100K FXYHP63K FXYAP50K/63K FXYLP63K FXYLMP63K	φ15.9	φ9.5
FXYCP125K FXYFP100K/125K FXYSP100K/125K FXYMP125K FXYHP100K	φ19.1	
FXYMP200K	φ25.4	φ12.7
FXYMP250K	φ28.6	

(V1095)



7.7.2 Outdoor Unit

RSXYP16-18-20KJY1

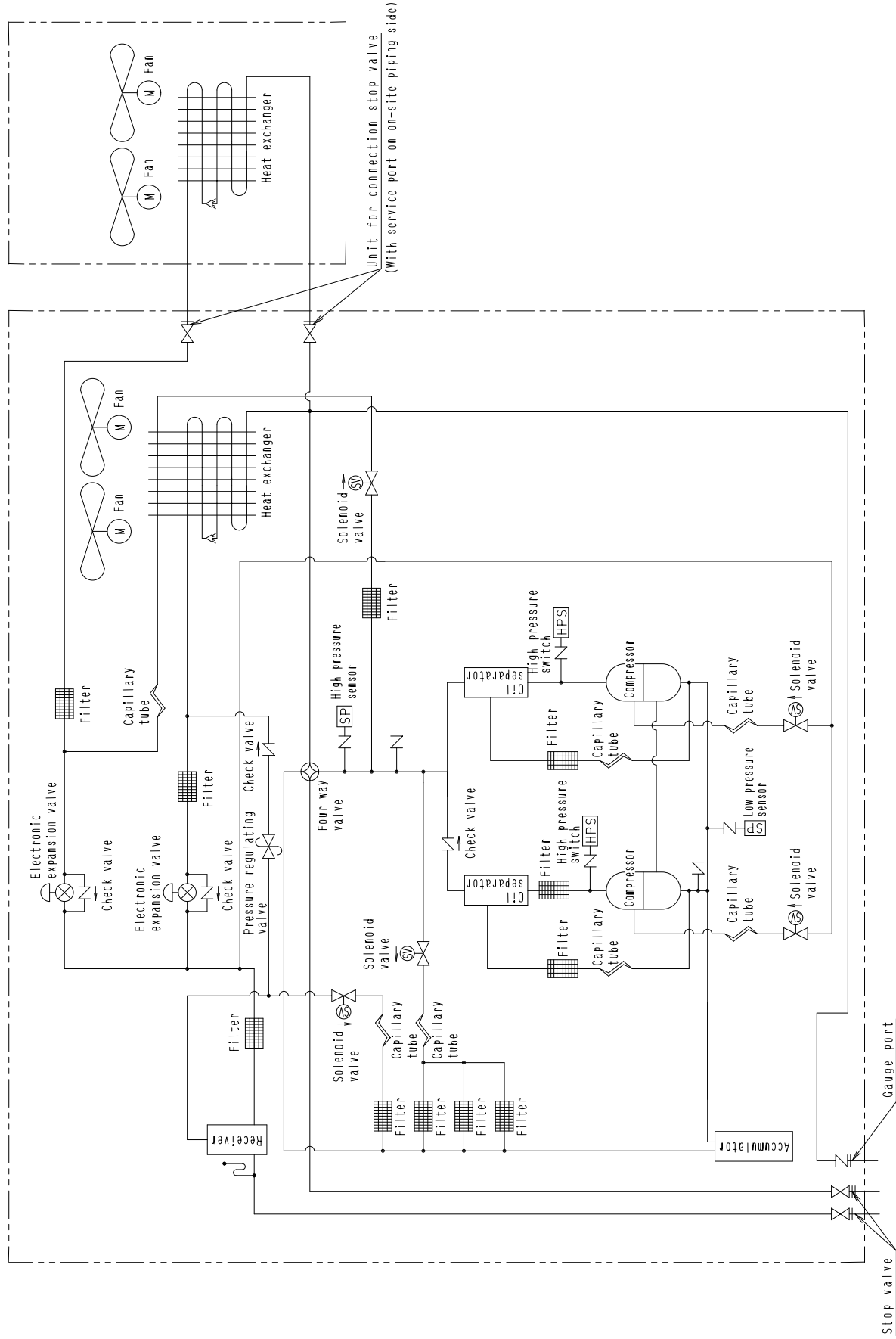

3D024909





RSXYP24-26-28-30KJY1

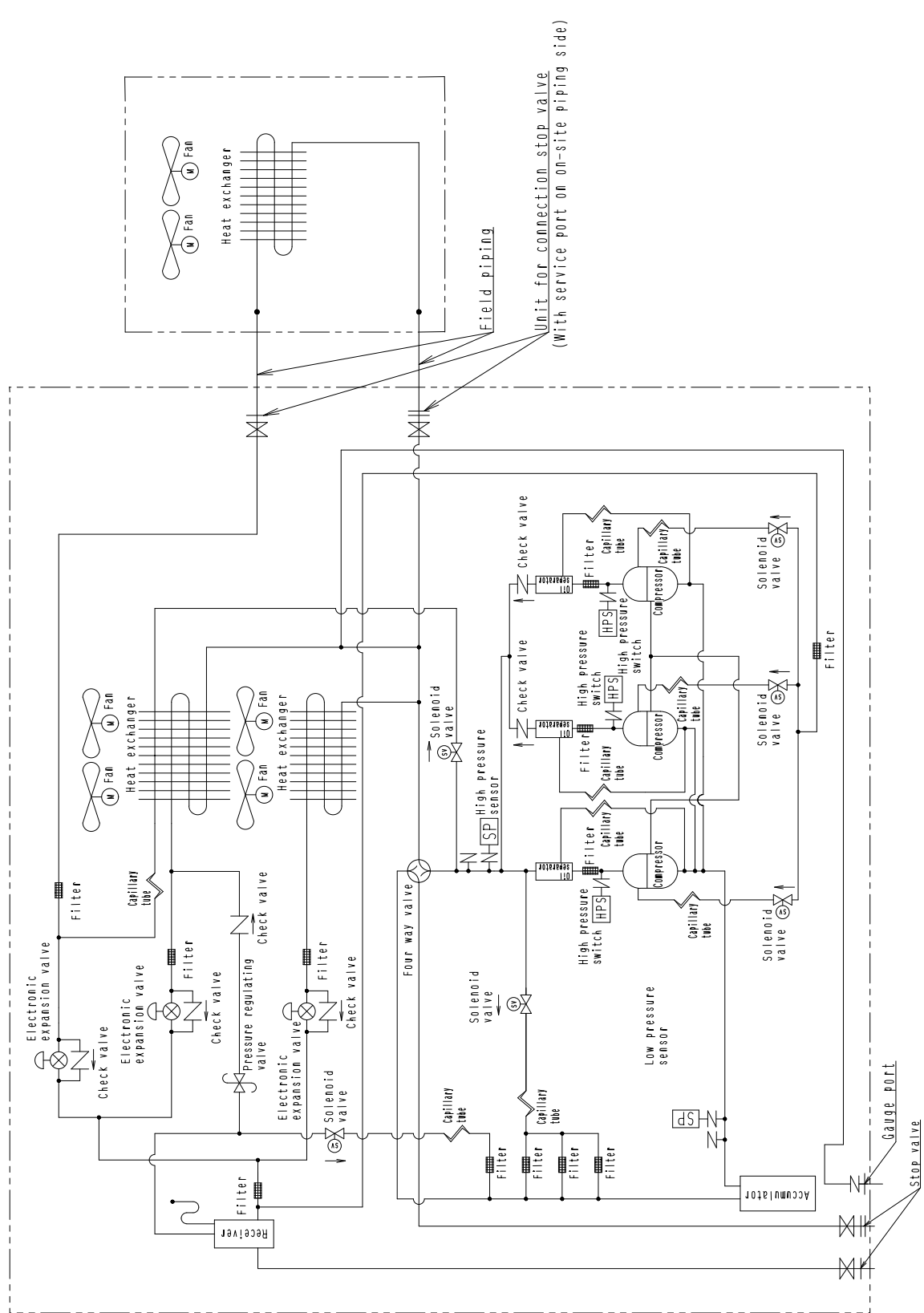

3D024910

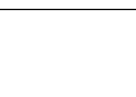
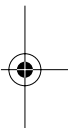

7.8 Wiring Diagram

7.8.1 Outdoor Unit

RSXYP16-18-20KJY1

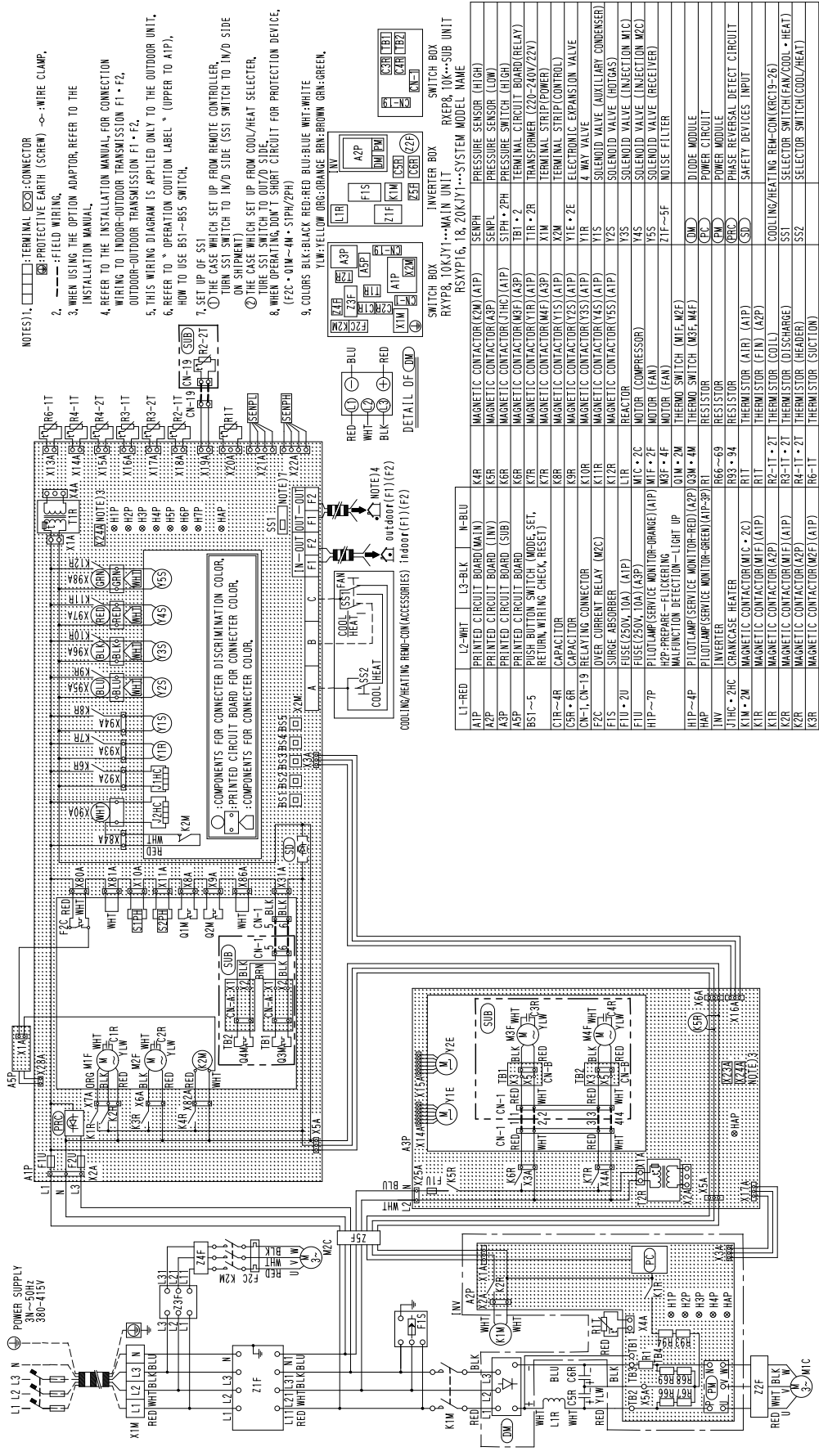

3D024953B

RSXYP24-26-28-30KJY1

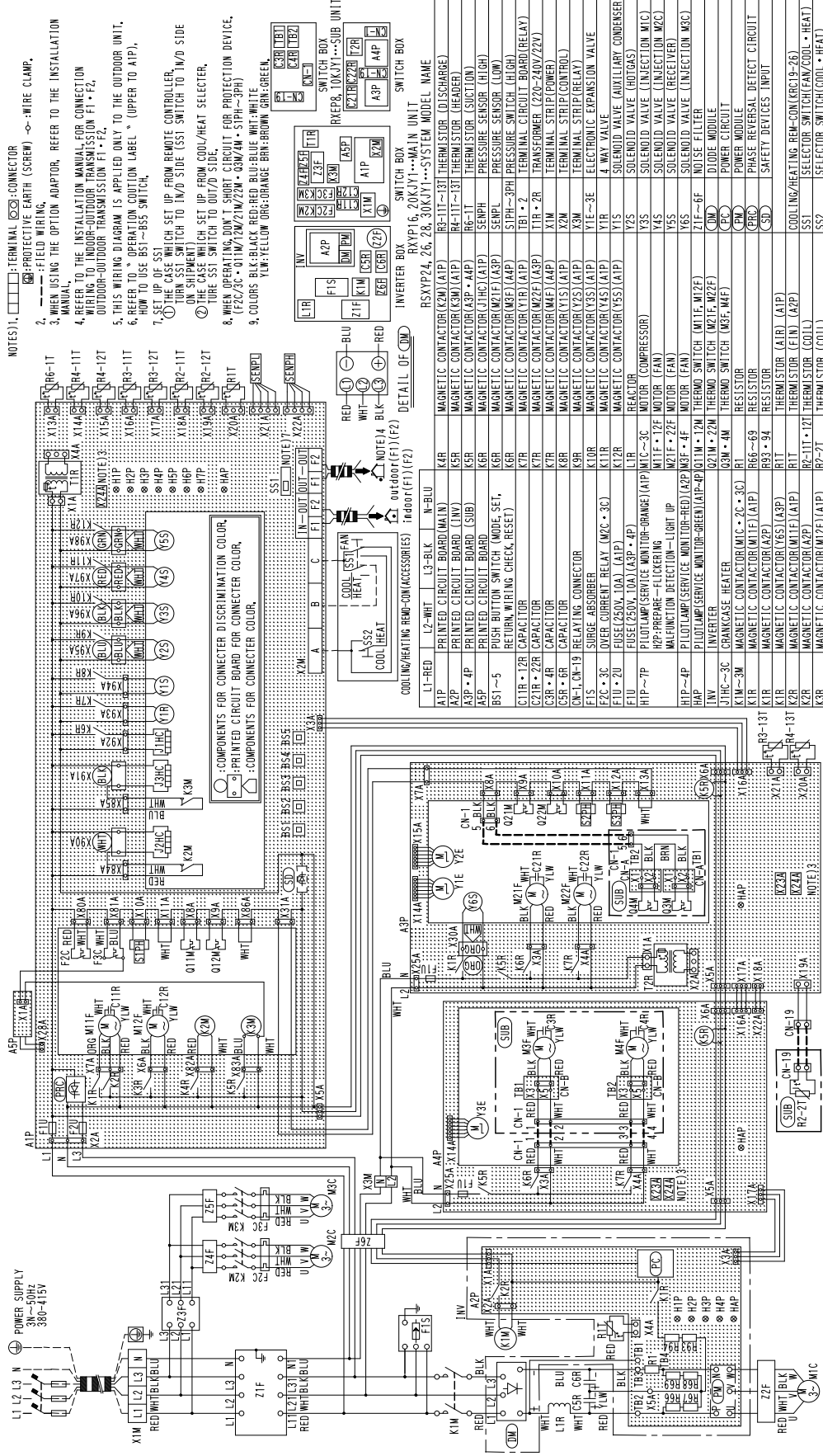

3D024954B

7.9 Bad Examples and Good Examples in Installation

7.9.1 Example 1: Signal interference due to use of multiple core cable (all model)

Situation Although for the purposes of group control there are only 2 units per group there are transmission malfunctions between the indoor units and the remote control and the remote control's address display is showing non-existent addresses such as 13 or 15.

Source of Problem and Remedial Action **Multiple core cable has been used** for at least part of the interconnecting wiring between the remote control and the indoor units. This has resulted in signal interference leading to a transmission malfunction.

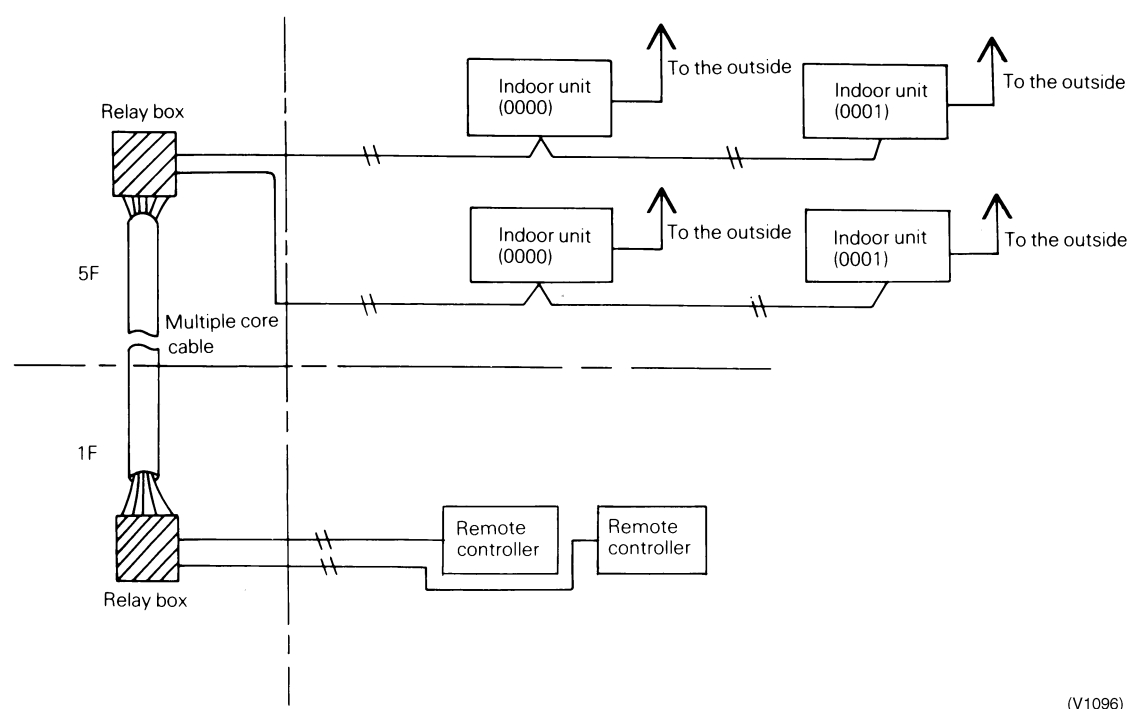

The multiple core cable was replaced by twin core cable and the fault disappeared.

Main Points

- Although twin core cable had been run from each unit, multiple core cable was used on the way.
- In schools, etc., because remote controls are often installed in a single first floor control room, it is easier to use a multi-core cable.
- Signal interference can result in non-existent addresses appearing on the display.

7.9.2 Example 2: Mismatch between cables connecting indoor and outdoor units and corresponding piping. (all model)

Situation The remote control is not showing any malfunction and the system is operating but there is no flow of warm air from the indoor unit (in heating mode).

Source of Problem and Remedial Action **The connecting cables and the corresponding piping were not correctly matched.**
Recabling was carried out and the fault disappeared.

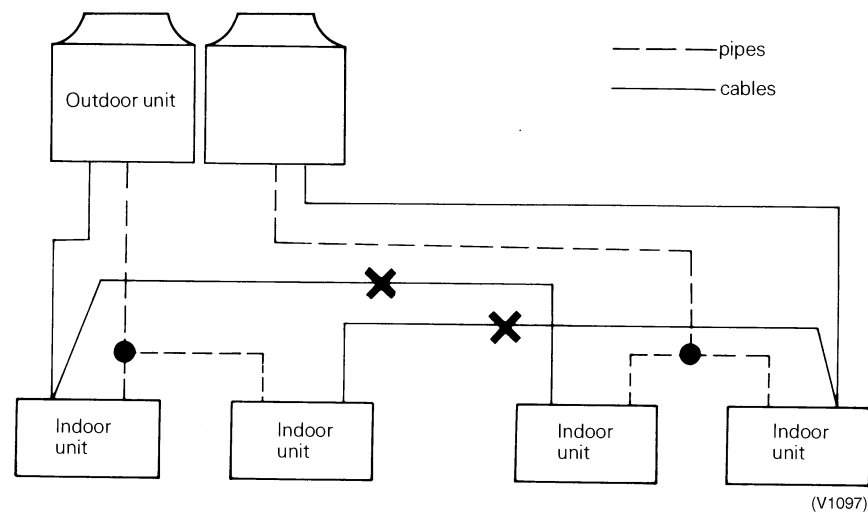

Main Points

- Special care must be taken when the pipework and cabling are carried out by different people.
- Run each indoor unit in turn to check that the system is correctly matched.

7.9.3 Example 3: Drain pipe trap shape defective

Situation Indoor unit was fitted with a drain trap but a leak occurred during subsequent operation.

Source of Problem and Remedial Action The trap was not properly shaped thus preventing it from functioning effectively as a trap and resulting in drain leakage. The trap was reshaped and the fault disappeared.

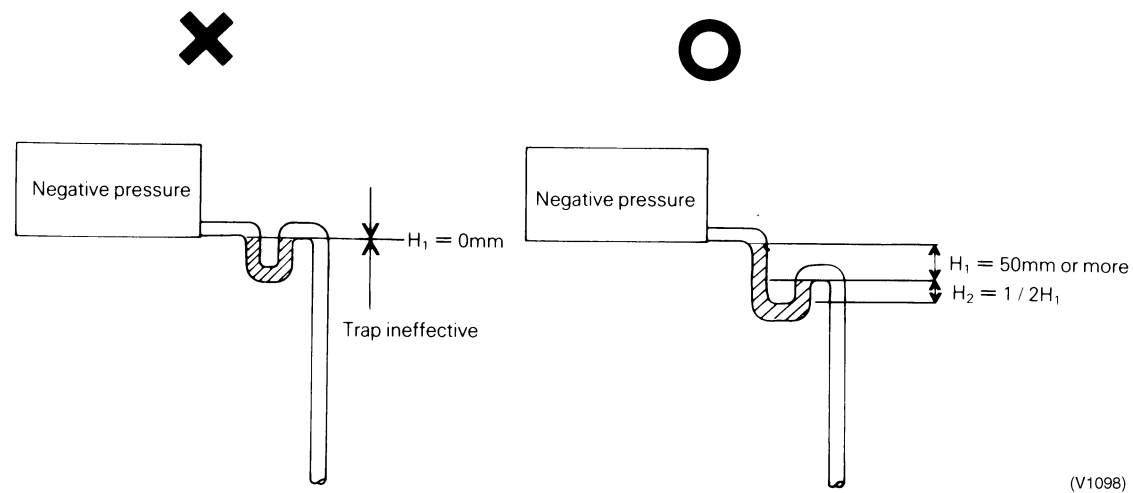

Main Points

- Duct types (40~125) require a drain trap.
Reason: There is resistance on the air inlet side caused by the heat exchanger and air filter and this in turn creates negative pressure in relation to the atmospheric pressure on the discharge side. If there is no drain trap then air will be drawn in from the drain pipe and the waste water splashed around giving rise to the risk of water overflowing from the drain pan. To avoid this problem it is therefore necessary to design a trap which takes account of the maximum negative pressure which is likely to be created on the suction side.

7.9.4 Example 4: Pressure down despite absence of leaks during air tight test (all model)

Situation

In order to carry out local air tight tests on the refrigerant piping the system was pressurized (3.33KPa) via the liquid pipe service port and after 24 hours the pressure was found to have fallen. The local refrigerant piping alone does not lose any pressure. Maybe the gas leak is supposed to be located in the indoor unit itself.

Source of Problem and Remedial Action

The system was pressurized from the liquid pipe side and the gas pipes were therefore not pressurized. The system was then left under pressure for 24 hours but during that time gas leaked through into the gas pipes due to internal leaks within the solenoid and check valves and the gas pressure inside the liquid pipes consequently dropped.

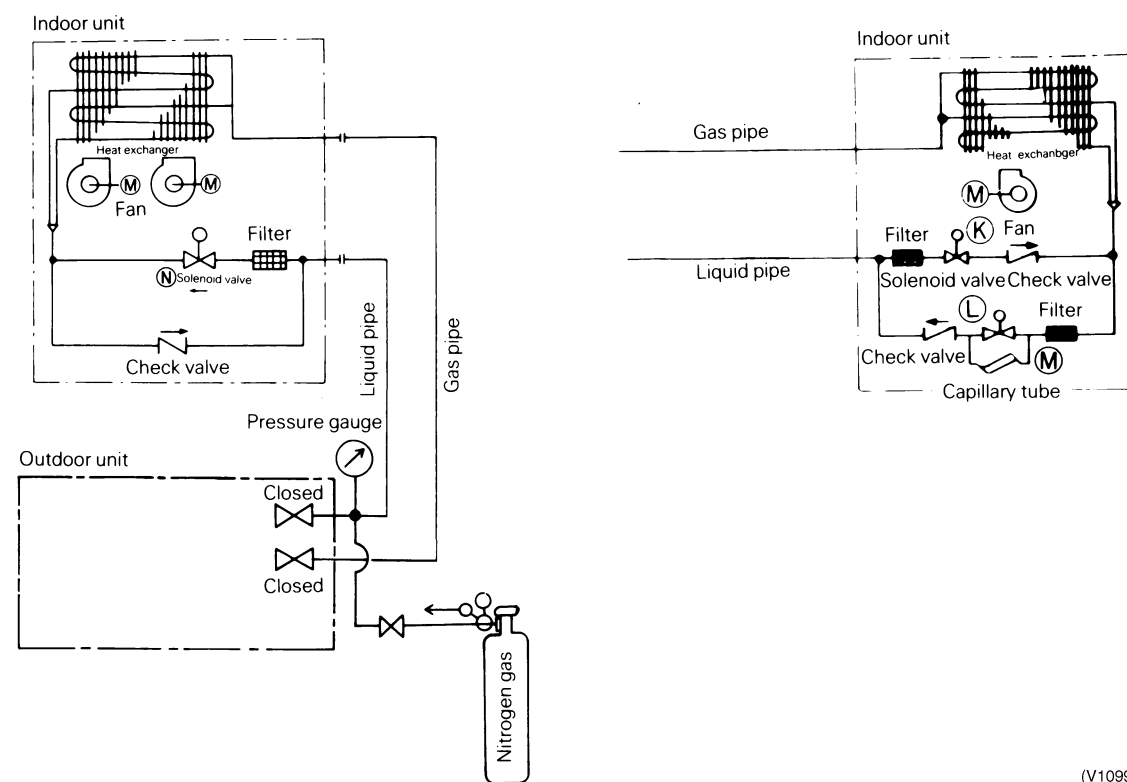

Main Points

When carrying out air tight tests on local pipework **it is essential that the system be pressurized via both the liquid pipes and the gas pipes.**

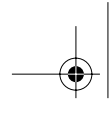

7.9.5 Example 5: Excessive noise due to incorrect angling of REFNET joints

Situation

The noise of the refrigerant flow during defrosting is excessive.

Source of Problem and Remedial Action

The angle of the fittings was incorrect and needed to be rectified as shown in the following figure.

1. REFNET joints

The REFNET joints should be installed such that branches meet the main pipe either horizontally or vertically at an angle of exactly 90 degrees.

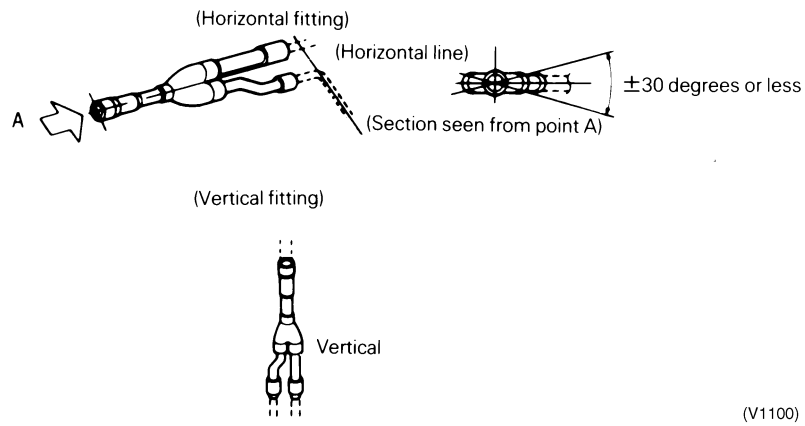

2. REFNET header

The REFNET header is a lateral flow pipe and should be fitted so as to allow horizontal branch fittings. (Vertical or sloping fitting is not permissible.)

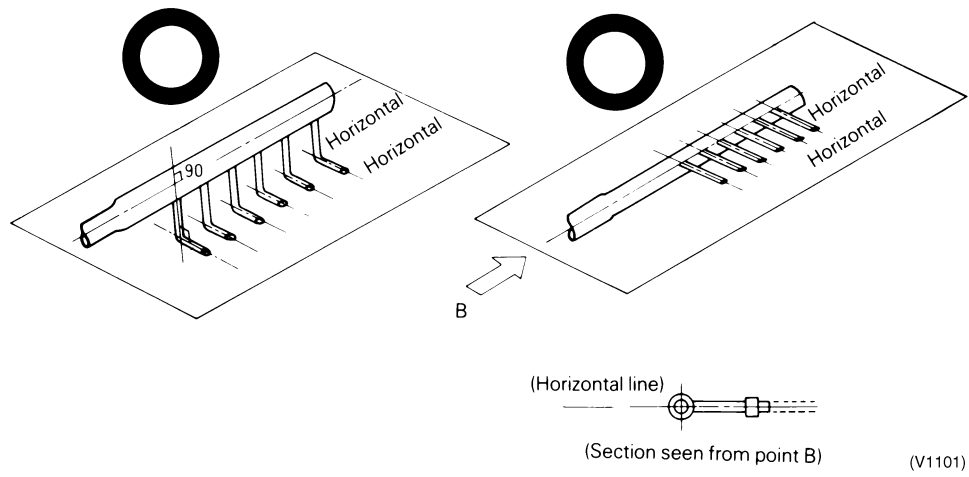

Main Points

- Reasons for using refrigerant branch kit
Fittings of REFNET joints or headers which are not carried out in strict accordance with the principles outlined here may result in complaints relating, for example, to "poor performance" of the system or "noisy refrigerant flow". (To prevent unbalance flow or oil shortage)

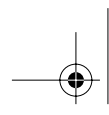

7.9.6 Example 6: Cracks develop in field pipes due to thermal expansion and contraction

Situation Refrigerant piping has developed cracks in soldered points and is leaking gas.

Cause Both ends of the pipe have been tightly fixed in place.
↓
Starting and stopping the compressor has caused temperature to vary, thus the pipes have expanded and contracted which places stress on soldered parts.
↓
Cracks have formed because of repeated expansion and contraction.

Remedial Action Fit the pipe with a loop as shown in the below drawing.

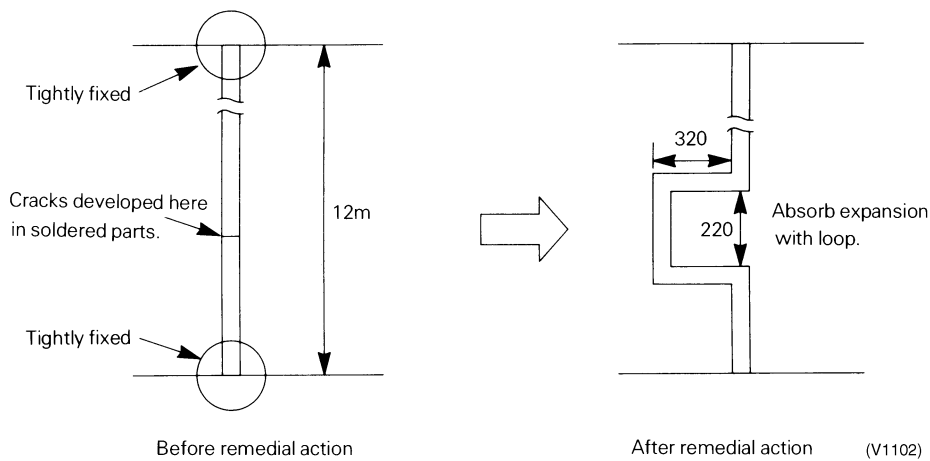

Main Points ■ Take thermal expansion and contraction along the spline into consideration when installing pipe supports.

For Your Reference Expansion (m) = Full length × Coefficient of thermal expansion × Rise in temperature
Coefficient of thermal expansion for copper: 16.5×10^{-6}
Example For a pipe length of 10 m and a rise in temperature of 50°C, expansion reaches 8.2 mm.

7.9.7 Example 7: Transmission wiring between the cool/heat selector and the outdoor unit is too close to a high voltage wire.

Situation Heating is indicated despite having selected cooling with the cool/heat selector.

Cause and Remedial Action The transmission wiring between the cool/heat selector and the outdoor unit is too close to a high voltage wire. An induced voltage is, therefore, being impressed on the transmission wiring which is causing a heating/cooling malfunction in the outdoor unit PC board.

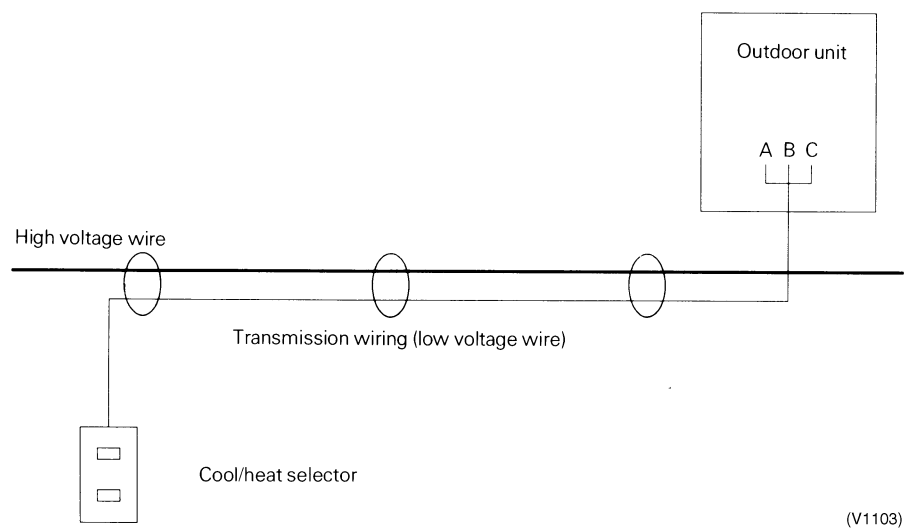

Bypassing the transmission wiring will allow the unit to function normally.

Main Points

- Keep low and high voltage wiring away from each another.

7.9.8 Example 8: The centralized control group number cannot be set (Inverter K Series).

Situation An attempt was made to set the centralized control group number with the indoor unit remote control, but "00" cannot be selected in the field setting mode.

Cause

1. The central remote control or unified ON/OFF control is OFF.
2. The central remote control or unified ON/OFF control, or indoor unit is not wired to the centralized control line (F1 & F2).

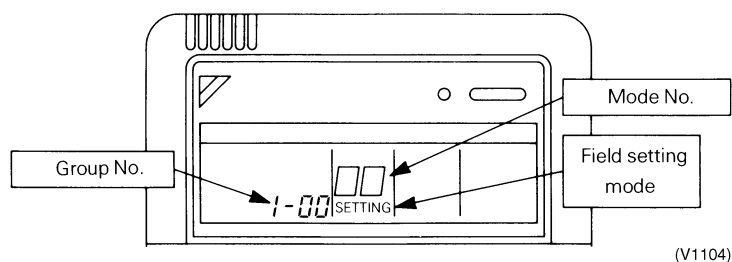

Remedial Action Supply power to either the central remote control or unified ON/OFF control.
Wire the central remote control or unified ON/OFF control, or indoor unit to the centralized control line.

Main Points

- When communications with the central remote control are down, "00" cannot be selected in the field setting mode.
- Activate power to the central remote control, unified ON/OFF control and indoor unit before setting the centralized control group number.

7.9.9 Example 9: "88" cannot be cleared from the central remote control.

Situation The display on the central remote control does not change from its initial state after turning power ON.

Initial display of the central remote control

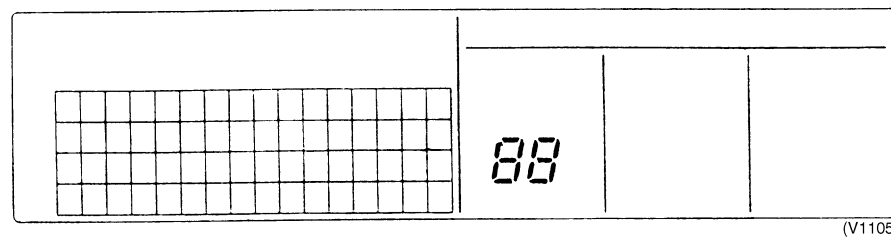

Cause

1. None of the indoor units connected to the central remote control have been given a group No.
2. The connector for setting the master control inside the central remote control is disconnected.

Remedial Action

- Set a centralized control group No. for each indoor unit with the respective remote controls.
- Connect the connector for setting the master control in one of the central remote control.

Main Points

- If the setting for master control has been changed, reset the power to the unit at the ON/OFF switch or the forced reset switch of the control.
- Activate power to the central remote control, unified ON/OFF control and indoor unit before setting the centralized control group No.
- For details on how to set the centralized control group number, refer to the installation manual.

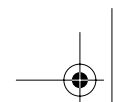

Part 2 Installation Manual

1. Introduction	124
1.1 Introduction.....	124
1.2 Cautions in Installation	125
1.3 Combination	126
1.4 Standard Operation Limit.....	127
1.5 Standard Supplied Accessories.....	128
1.6 Optional Accessories.....	129
1.7 Technical Specifications	130
1.8 Electrical Specifications.....	131
2. Main Components	132
2.1 Main Components	132
3. Selection of Location.....	133
3.1 Selection of Location	133
4. Inspecting and Handling the Unit	134
4.1 Inspecting and Handling the Unit.....	134
5. Unpacking and Placing the Unit	135
5.1 Unpacking and Placing the Unit	135
6. Refrigerant Piping	136
6.1 Refrigerant Piping.....	136
6.2 Selection of Piping Material.....	137
6.3 Connecting the Refrigerant Piping.....	138
6.4 Leak Test and Vacuum Drying	143
6.5 Pipe Insulation	144
6.6 Additional Refrigerant Charge	145
7. Field Wiring	147
7.1 Field Wiring.....	147
7.2 Internal Wiring	148
7.3 Optional Parts Cool/Heat Selector.....	150
7.4 Power Circuit and Cable Requirements	151
7.5 General.....	152
7.6 Examples.....	153
8. Before Operation.....	158
8.1 Checks before Initial Start-Up.....	158
8.2 Test Run	159
9. Caution for Refrigerant Leaks	163
9.1 Caution for Refrigerant Leaks.....	163
10. Appendix of Installation	165
10.1 Example of Connection	165

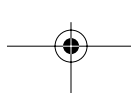

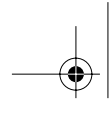

1. Introduction

1.1 Introduction

This installation manual concerns VRV plus series, RSXYP. These units are designed for outdoor installation and used for cooling and heatpump applications. The units are available in 7 standard sizes with nominal cooling capacities ranging from 43.8 to 82.1kW and nominal heating capacities ranging from 43.8 to 82.1kW.

The RSXYP units can be combined with Daikin VRV series indoor units for air conditioning purposes.

The present installation manual describes the procedures for unpacking, installing and connecting the RSXYP units. Installation of the indoor units is not described in this manual. Always refer to the installation manual supplied with these units for their installation.

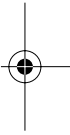

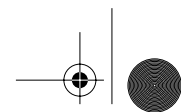

1.2 Cautions in Installation



Caution 1 Read this manual attentively before starting up the unit. Do not throw it away. Keep it in your files for future reference.



Caution 2 Improper installation or attachment of equipment or accessories could result in electric shock, short-circuit, leaks, fire or other damage to the equipment. Be sure only to use accessories made by DAIKIN which are specifically designed for use with the equipment and have them installed by a professional. If unsure of installation procedures or use, always contact your DAIKIN dealer for advice and information.



Caution 3 The refrigerant, R-407C, requires strict cautions for keeping the system clean, dry and tight.

A.Clean and dry
Foreign materials (including mineral oils such as SUNISO oil or moisture) should be prevented from getting mixed into the system.

B.Tight
R-407C does not contain any chlorine, does not destroy the ozone layer, and does not reduce the earth's protection against harmful ultraviolet radiation.
R-407C can contribute slightly to the greenhouse effect if it is released. Therefore we should take special attention to check the tightness of the installation.
Read the chapter "Refrigerant piping work" carefully and follow these procedures correctly.



Caution 4 Since R-407C is a mixed refrigerant, the required additional refrigerant must be charged in its liquid state. (If the refrigerant is charged in a state of gas, its composition changes and the system will not work properly.)
The connected indoor units must be of the FXY--P--series, indoor units designed exclusively for R-407C. If indoor units for R22 are connected, normal operation cannot be assured.

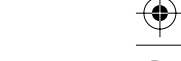

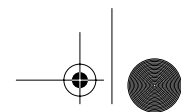

1.3 Combination

The combination with indoor units is as follows:

- The possible combination of the outdoor unit with indoor units is in function of the total capacity index of these indoor units and must be within the range as specified below:

Outdoor Unit

RSXYP16 < RXYP8 + RXEP8 >.....	200 - 520
RSXYP18 < RXYP10 + RXEP8 >.....	225 - 585
RSXYP20 < RXYP10 + RXEP10 >.....	250 - 650
RSXYP24 < RXYP16 + RXEP8 >.....	300 - 780
RSXYP26 < RXYP16 + RXEP10 >.....	325 - 845
RSXYP28 < RXYP20 + RXEP8 >.....	350 - 910
RSXYP30 < RXYP20 + RXEP10 >.....	375 - 975

- Up to 20 indoor units can be connected to 1 outdoor unit RSXYP16,18 and 20.
Up to 32 indoor units can be connected to 1 outdoor unit RSXYP24,26,28 and 30.
- Make sure to connect indoor units designed exclusively for R-407C.(FXY--P--series)
- Refer to the catalogue and/or engineering data book for model numbers of indoor units which can be connected.



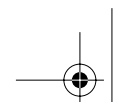

1.4 Standard Operation Limit

The figures below assume following operating conditions for indoor and outdoor units:

Equivalent pipe length.....5m

Level difference.....0m

Cooling

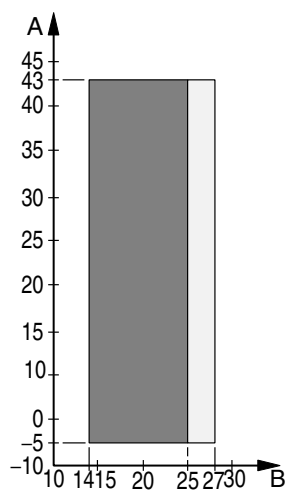

Heating

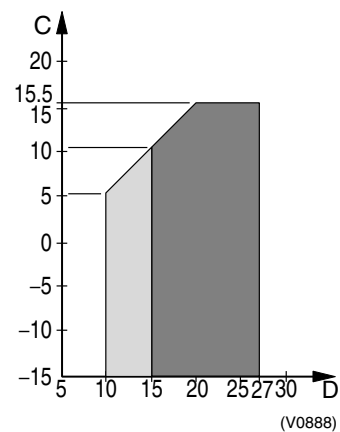

- A Outdoor temperature (°CDB)
- B Indoor temperature (°CWB)
- C Outdoor temperature (°CWB)
- D Indoor temperature (°CDB)
- Range for continuous operation
- Range for pull down operation
- Range for warming up operation

1.5 Standard Supplied Accessories

RXYP8,10

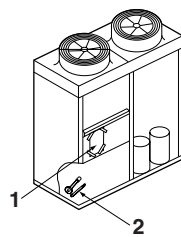



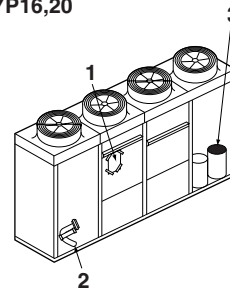



RXYP16,20

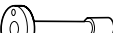

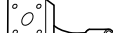



Fig. 30
(V0883)

Accessories are attached in the main unit , RXYP.

RSXYP16,18,20

Tie-Wrap (1)	9		(V0889)
Gas Side Attached Pipe (2) (for connecting main and sub unit)	1		(V0890)
Gas Side Attached Pipe (2) (for connecting main and sub unit)	1		(V0891)
Gas Side Attached Pipe (2)	1		(V0892)
Gas Side Attached Pipe (2) (for bottom piping)	1		(V0893)
Connection Cable : Low Voltage (2)	1		(V0894)
Connection Cable : High Voltage (2)	1		(V0895)
Installation Manual (1)	1		
Operation Manual (1)	1		

RSXYP24,26,28,30

Tie-Wrap (1)	11		(V0889)
Gas Side Attached Pipe (2) (for connecting main and sub unit)	1		(V0890)
Gas Side Attached Pipe (2) (for connecting main and sub unit)	1		(V0893)
Gas Side Attached Pipe (2) (for front-piping)	1		(V0896)
Liquid Side Attached Pipe (2) (for front-piping) Do not use for RSXYP24	1		(V0897)
Connection Cable : Low Voltage (3)	1		(V0894)
Connection Cable : High Voltage (3)	1		(V0895)
Installation Manual (1)	1		
Operation Manual (1)	1		



Notes:

- Attached pipes are only for front piping. (RSXYP24-30)
- For side or bottom piping , see "Optional accessories"

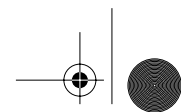

1.6 Optional Accessories

The outdoor unit requires purchasing the following refrigerant branch kits separately. Make sure to use exclusive parts for R-407C.

Refnet Header	KHRP26K11H	KHRP26K17H	KHRP26K18H
	KHRP26K37H	KHRP26K40H	
Refnet Joint	KHRP26K11T	KHRP26K17T	KHRP26K18T
	KHRP26K37T	KHRP26K40T	KHRP26K75T
Pipe size reducer	KHRP26K40TP	KHRP26K40HP	KHRP26K75TP
Piping Kit for Side-Piping	KHF30A30L		
Piping Kit for Bottom-Piping	KHF30A30U		



Note:

- Refer to chapter “Example of connection” on page 165 for selection of the refrigerant branch kits you need.
- Piping kit for side and bottom piping are for RSXYP24,26,28 and 30.



1.7 Technical Specifications

General			RSXYP16	RSXYP18	RSXYP20	RSXYP24	RSXYP26	RSXYP28	RSXYP30
Nominal Cooling Capacity		kW	43.8	49.3	54.7	65.7	71.2	76.6	82.1
Nominal Heating Capacity		kW	43.8	49.3	54.7	65.7	71.2	76.6	82.1
Nominal Input Cooling/Heating		kW	15.7 / 14.2	18.1 / 15.5	20.2 / 16.9	25.0 / 21.4	26.9 / 21.9	28.7 / 23.9	31.2 / 27.1
Dimensions HxWxD	Main Unit	mm	1440×1280 ×690	1440×1280 ×690	1440×1280 ×690	1450×2580 ×690	1450×2580 ×690	1450×2580 ×690	1450×2580 ×690
	Sub Unit	mm	1220×1280 ×690	1220×1280 ×690	1440×1280 ×690	1220×1280 ×690	1440×1280 ×690	1220×1280 ×690	1440×1280 ×690
Weight	Main Unit	kg	360	365	365	620	620	630	630
	Sub Unit	kg	95	95	105	95	105	95	105
Connections	Refrigerant Gas Inlet	inch	1 3/8 OD	1 3/8 OD	1 3/8 OD	1 5/8 OD	1 5/8 OD	1 5/8 OD	1 5/8 OD
		mm	34.9	34.9	34.9	41.3	41.3	41.3	41.3
	Refrigerant Liquid Inlet	inch	5/8 flare	6/8 flare	6/8 flare	6/8 flare	7/8 OD	7/8 OD	7/8 OD
		mm	15.9	19.1	19.1	19.1	22.2	22.2	22.2
	Refrigerant Gas Inlet for Sub Units	inch	1 1/8 OD	1 1/8 OD	1 1/8 OD	1 1/8 OD	1 1/8 OD	1 1/8 OD	1 1/8 OD
		mm	28.6	28.6	28.6	28.6	28.6	28.6	28.6
Refrigerant Liquid Inlet for Sub Units	inch	1/2 flare	1/2 flare	1/2 flare	1/2 flare	1/2 flare	1/2 flare	1/2 flare	
	mm	12.7	12.7	12.7	12.7	12.7	12.7	12.7	

(1) Refer to the engineering data book for the complete list of specifications.

(2) The nominal cooling capacity is based on:

- indoor temperature: 27°CDB/19°CWB
- outdoor temperature: 35°CDB
- pipe length: 5m
- level difference: 0m

(3) The nominal heating capacity is based on:

- indoor temperature: 20°CDB
- outdoor temperature: 7°CDB/6°CWB
- pipe length: 5m
- level difference: 0m

(4) The nominal input includes total input of the unit: compressor, fan motor and control circuit.

Compressor			RSXYP16	RSXYP18	RSXYP20	RSXYP24	RSXYP26	RSXYP28	RSXYP30
Model			JT236DAVTYE + JT212DATYE	JT236DAVTYE + JT265DATYE	JT236DAVTYE + JT265DATYE	JT236DAVTYE + JT236DATYE + JT236DATYE	JT236DAVTYE + JT236DATYE + JT236DATYE	JT236DAVTYE + JT300DATYE + JT300DATYE	JT236DAVTYE + JT300DATYE + JT300DATYE
	Oil Type		DAPHNE FVC68D	DAPHNE FVC68D	DAPHNE FVC68D	DAPHNE FVC68D	DAPHNE FVC68D	DAPHNE FVC68D	DAPHNE FVC68D
Oil Charge Volume	l		4.0 + 4.0	4.0 + 4.0	4.0 + 4.0	4.0 + 4.0 + 4.0	4.0 + 4.0 + 4.0	4.0 + 4.0 + 4.0	4.0 + 4.0 + 4.0
Crankcase Heater	W		50 + 50	50 + 50	50 + 50	50 + 50 + 50	50 + 50 + 50	50 + 50 + 50	50 + 50 + 50
Refrigerant Type			R-407C	R-407C	R-407C	R-407C	R-407C	R-407C	R-407C
Refrigerant Charge	kg		15.5	16.6	16.6	23.3	23.3	25.3	25.3
Condenser			RSXYP16	RSXYP18	RSXYP20	RSXYP24	RSXYP26	RSXYP28	RSXYP30
Nominal Air Flow	m ³ /min		320	320	340	490	510	490	510
Fan Motor Output	W		140 × 2,230 × 2	140 × 2,230 × 2	140 × 2,230 × 2	140 × 3,230 × 3	140 × 3,230 × 3	140 × 3,230 × 3	140 × 3,230 × 3



1.8 Electrical Specifications

Model			RSXYP16	RSXYP18	RSXYP20	RSXYP24	RSXYP26	RSXYP28	RSXYP30
Power Supply	- Phase		3N~	3N~	3N~	3N~	3N~	3N~	3N~
	- Frequency	Hz	50	50	50	50	50	50	50
	- Voltage	V	380 – 415	380 – 415	380 – 415	380 – 415	380 – 415	380 – 415	380 – 415
	- Voltage Tolerance	%	+ 6 / - 10	+ 6 / - 10	+ 6 / - 10	+ 6 / - 10	+ 6 / - 10	+ 6 / - 10	+ 6 / - 10
	- Recommended Fuses	A	45	50	60	60	70	70	70
Compressor	- Phase		3~	3~	3~	3~	3~	3~	3~
	- Frequency	Hz	50	50	50	50	50	50	50
	- Voltage	V	380 – 415	380 – 415	380 – 415	380 – 415	380 – 415	380 – 415	380 – 415
	- Nominal Running Current	A	25.4~27.8	28.3~30.9	28.4~31.0	35.2~38.4	40.5~44.2	40.7~44.4	40.7~44.4
Control and Fan Motor	- Phase		1~	1~	1~	1~	1~	1~	1~
	- Frequency	Hz	50	50	50	50	50	50	50
	- Voltage	V	220 – 240	220 – 240	220 – 240	220 – 240	220 – 240	220 – 240	220 – 240
	- Nominal Running Current	A	4.5	4.5	4.5	6.7	6.7	6.7	6.7

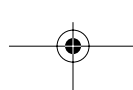
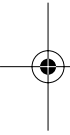



2. Main Components

2.1 Main Components

For main components and function of the main components, refer to the Engineering Data Book and service manual Si33-002.

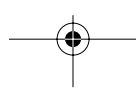
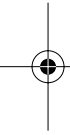

3. Selection of Location

3.1 Selection of Location

This unit, both indoor and outdoor, is suitable for installation in a commercial and light industrial environment. If installed as a household appliance it could cause electromagnetic interference.

The VRV plus outdoor units should be installed in a location that meets the following requirements:

1. The foundation is strong enough to support the weight of the unit and the floor is flat to prevent vibration and noise generation.
2. The space around the unit is adequate for servicing and the minimum space for air inlet and air outlet is available. (Refer to figure 1 and choose one of both possibilities.)

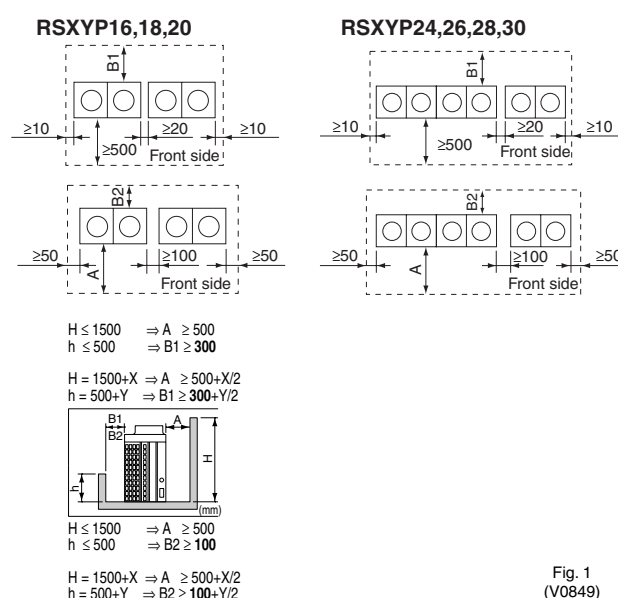

Fig. 1
(V0849)

3. There is no danger of fire due to leakage of inflammable gas.
4. Ensure that water cannot cause any damage to the location in case it drips out the unit (e.g. in case of a blocked drain pipe).
5. The piping length between the outdoor unit and the indoor unit may not exceed the allowable piping length. (See "Allowable pipe length" on page 94.)
6. Select the location of the unit in such a way that neither the discharged air nor the sound generated by the unit disturb anyone.
7. Make sure that the air inlet and outlet of the unit are not positioned towards the main wind direction. Frontal wind will disturb the operation of the unit. If necessary, use a windscreen to block the wind.



Caution

1. An inverter air conditioner may cause electronic noise generated from AM broadcasting. Examine where to install the main air conditioner and electric wires, keeping proper distances away from stereo equipment, personal computers, etc.

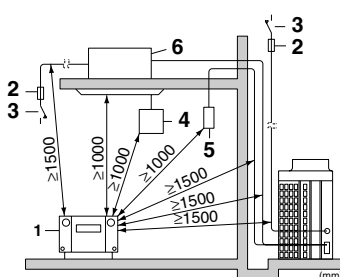

Fig. 2
(V0850)

1. Personal Computer or Radio
2. Fuse
3. Earth Leak Detector
4. Remote Control
5. Cool/Heat Selector
6. Indoor Unit

If the electric wave of AM broadcasting is particularly weak, keep distances of 3m or more and use conduit tubes for power and transmission lines.

2. In heavy snowfall areas, select an installation site where snow will not affect operation of the unit.
3. The refrigerant R-407C itself is nontoxic, nonflammable and is safe. If the refrigerant should leak however, its concentration may exceed the allowable limit depending on room size. Due to this it could be necessary to take measures against leakage. Refer to the chapter 'Caution for refrigerant leaks'.



4. Inspecting and Handling the Unit

4.1 Inspecting and Handling the Unit

The units are packed in a wooden crate and attached on a wooden pallet.

At delivery, the package should be checked and any damage should be reported immediately to the carrier claims agent.

When handling the unit, take into account the following:

1.  Fragile, handle the unit with care.
2.  Keep the unit upright in order to avoid compressor damage.
2. Lift the unit preferably with a crane and 2 belts(1) of at least 8m or 10m (RXYP16,20) long.
3. When lifting the unit with a crane, always use protectors(2) to prevent belt damage and pay attention to the position of the unit's centre of gravity.

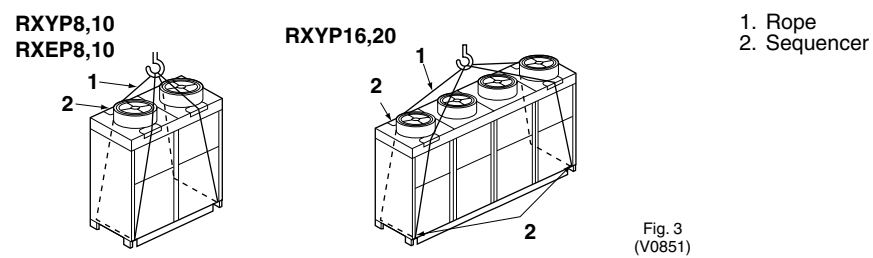

4. Bring the unit as close to its final installation position in its original package to prevent damage during transport.

5. Unpacking and Placing the Unit

5.1 Unpacking and Placing the Unit

1. Remove the wooden crate from the unit.
2. Remove the four screws fixing the unit to the pallet.
3. The unit must be installed on a solid longitudinal foundation (steelbeam frame or concrete) as indicated in figure 5.

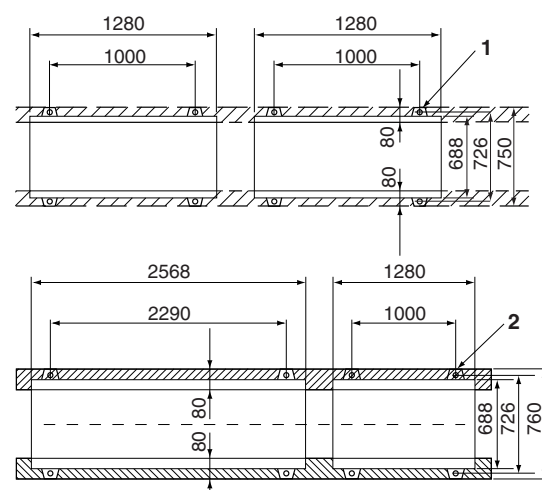

1. Fundamental bolt position ($\phi 15$ holes ... 8 places)

Fig. 5
(V0853)

Bad Example

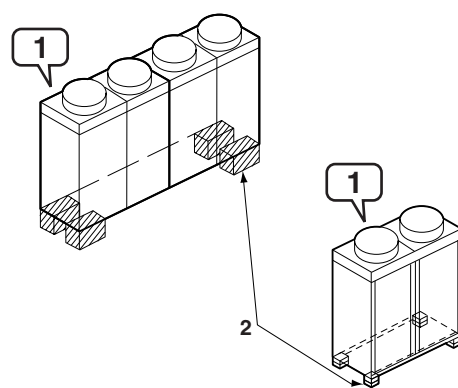

1. **X** No!
2. Do not use stands to support the corners.

Fig. 4
(V0852)

i Note: Maximum height of the foundation is 150mm.

4. Lift the unit from the pallet and place it on its installation position.
5. Fasten the unit in place using four anchor bolts M12.
6. Remove the upper and lower service plate.
7. When closing the service panels take care that the tightening torque does not exceed 4.1 Nm.
8. Remove the yellow shipping stays from the compressor support as shown in the figure (2 stays per single compressor). Tighten the installation bolts firmly again afterwards.

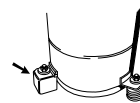

(V0898)



Caution

1. Prepare a water drainage channel around the foundation to drain waste water from around the unit.
2. If the unit is to be installed on a roof, check the strength of the roof and its drainage facilities first.
3. If the unit is to be installed on a frame, install the waterproofing board within a distance of 150mm under the unit in order to prevent infiltration of water coming from under the unit.



Refer "Installation of Outdoor Unit" page 51 for more foundation detail.

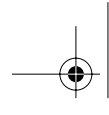

6. Refrigerant Piping

6.1 Refrigerant Piping



Caution

All field piping must be installed by a licensed refrigeration technician and must comply with relevant local and national regulations.



Notes:

- Use R-407C only when adding refrigerant.

- Installation tools:

Make sure to use installation tools (gauge manifold charge hose, etc.) that are exclusively used for R-407C installations to withstand the pressure and to prevent foreign materials (e.g. mineral oils such as SUNISO and moisture) from mixing into the system.

Vacuum pump (use a 2-stage vacuum pump with a non-return valve):

1. Make sure the pump oil does not flow oppositely into the system while the pump is not working.
2. Use a vacuum pump which can evacuate to -100.7 kPa (5Torr, -755mmHg).

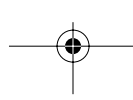
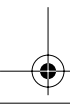
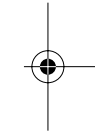

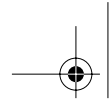

6.2 Selection of Piping Material

-
- Step 1** Foreign materials inside pipes (including oils for fabrication) must be 30mg/10m or less.
-
- Step 2** Use the following material specification for refrigerant pipping:
- construction material: Phosphoric acid deoxidized seamless copper for refrigerant.
 - size: Determine the proper size referring to chapter "Example of connection".
 - The wall thickness of the refrigerant piping should comply with relevant local and national regulations.
For R-407C the design pressure is 3.2 MPa.
-
- Step 3** Make sure to use the particular branches of piping that have been selected referring to chapter "Example of connection" on page 165.

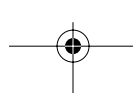
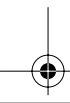
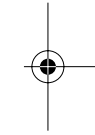
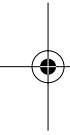

6.3 Connecting the Refrigerant Piping

1. Piping Installation

Installation of refrigerant piping is possible as front connection, side connection and bottom connection.



Caution

Be sure to use the attached pipe when carrying out piping work in the field.

Separately use the optional "KHF30A30L" or "KHF30A30U" piping kit when carrying out connections for the side and bottom on RSXYP24, 26, 28, and 30.

Connect the flange on the valve on the gas side before connecting the flare nut on the valve on the liquid side.

(Connecting the liquid side first will make it harder to connect the gas side.)

Be sure that the local piping does not touch other pipes, the bottom panel or side panel. Especially for the bottom and side connection, be sure to protect the gas piping with the provided insulation, to prevent it from coming into contact with the casing.

RSXYP16,18,20

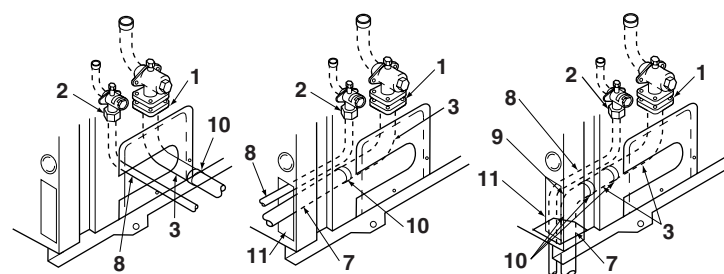

1. Flange
2. Flare nut
3. Gas side attached pipe
4. Gas side optional pipe
5. Liquid side attached pipe (Field supply, in case of RSXYP24)
6. Liquid side optional pipe (Field supply, in case of RSXYP24)
7. Gas side pipe (Field supply)
8. Liquid side pipe (Field supply)
9. Elbow (Field supply)
10. Brazing
11. Knock out hole (use a hammer)

RSXYP24,26,28,30

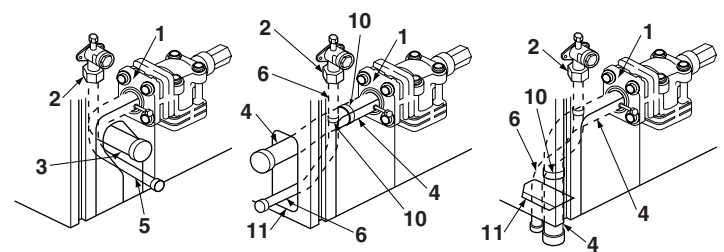

Fig. 6
(V0854)



Notes:

1. Front Connection
 - Make sure to close the piping intake hole again after installation work.
 - Stop valve cover

RSXYP16,18,20 RSXYP24,26,28,30

1. Part to cut off (Cut off the slit part.)
2. Part to cut off (Cut grooves on the back side.)

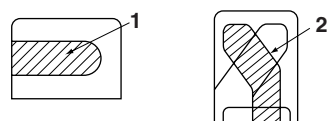

Fig. 7
(V0855)

2. Side Connection
 - Use a hammer and knock out the hole.
 - Piping kit "KHF30A30L" is required for RSXYP24,26,28 and 30.



Refer the optional "KHF30A30L" or "KHF30A30U" piping kit on page 104 for more detail.

3. Bottom Connection

- Piping kit "KHF30A30U" is required for RSXYP24,26,28 and 30.
- For RSXYP16,18 and 24, bend the liquid side pipe as below and connect it to the stop valve.

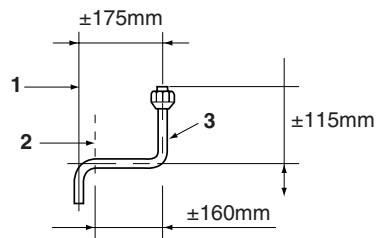

- 1. Bending position
- 2. Cutting position in case of using elbow
- 3. Liquid side

Fig. 8 (V0856)

RSXYP16,18,20

Bend the gas side pipe as below.

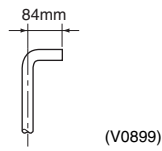

Connect with attached pipes.

- 1. Cut the attached pipe

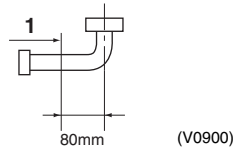

- 1. Cutting position

- 2. Connect attached pipes and field pipe

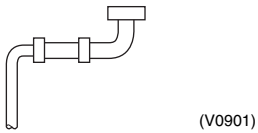

RSXYP24,26,28,30

The diagram at right shows the opening on the underside for connecting the bottom. Note that piping connected with elbow-pipes (procured locally) cannot pass through the opening.

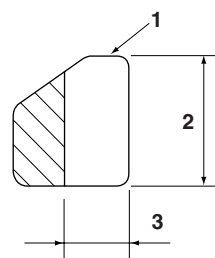

- 1. Knock out hole
- 2. Aprx. 110mm
- 3. Aprx. 54mm

Fig. 9 (V0857)

2. Piping Between Main Unit (RXYP-) and Sub Unit (RXEP-)

- Be sure to open the cornered knock out hole on the left panel of the sub unit when connecting the branch piping between outdoor units

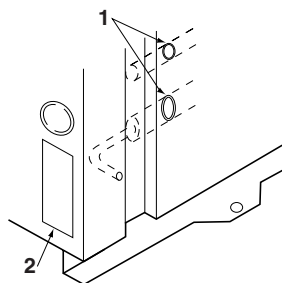

Fig. 10 (V0858)

1. Location to disconnect: the V groove part (Sub unit)
2. Knock out hole (Knock out the hole using a hammer, etc.)

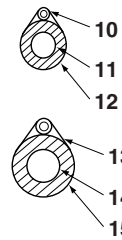
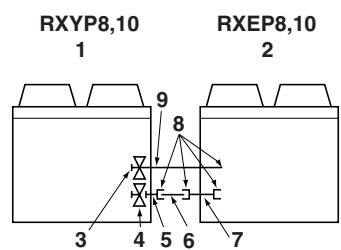

Fig. 11 (V0859)

1. RXYP8,10 (Main unit)
2. RXEP8,10 (Sub unit)
3. Flare nut
4. Flange
5. Gas side attached pipe
6. Gas side branch piping (φ28.6)
7. Gas side attached pipe
8. Brazing
9. Liquid side branch piping (φ12.7)
10. Cable (Low voltage)
11. Liquid line
12. Insulation material
13. Cable (High voltage)
14. Gas line
15. Insulation material

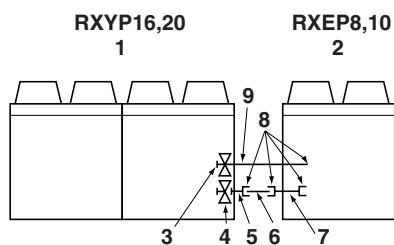

Fig. 12 (V0860)

1. RXYP16,20 (Main unit)
2. RXEP8,10 (Sub unit)
3. Flare nut
4. Flange
5. Gas side attached pipe
6. Gas side branch piping (φ28.6)
7. Gas side attached pipe
8. Brazing
9. Liquid side branch piping (φ12.7)



Note: ■ After brazing, pass the connection cable through the through-slots. Pass the connection cable through the through-slots only with flange disconnected. (If the flange is still connected, the connector of the connection cable will not pass through.)

3. Piping Limitation

Make sure to perform the piping installation within the range of the maximum allowable pipe length, allowable level difference and allowable length after branching as indicated in chapter "Example of connection".

4. REFNET Joint

For installation of the refrigerant branching kit, refer to the installation manual delivered with the kit. Mount the REFNET joint so that it branches either horizontally or vertically.

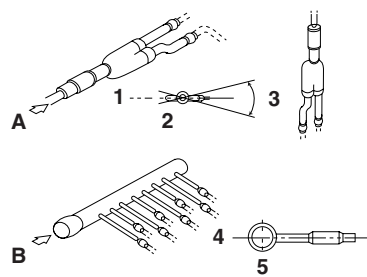

Fig. 13 (V0861)

1. (Horizontal wires)
2. (A-arrow diagram)
3. (Up to ±30° or vertically.)
Mount the REFNET header so that it branches horizontally.
4. (Horizontal wires)
5. (B-arrow diagram)

5. Pipe Connection

- Apply ether or ester oil around the flare portions before connecting.
- Only proceed with brazing after carrying out "Refrigerant pipe flushing" (note) or while releasing nitrogen into the refrigerant piping (note).
If brazing is done without "Refrigerant pipe flushing" or without nitrogen being released into the piping, a thick oxidized film will form on the inside of the piping, affecting the valves and compressors in the refrigerant system, and making normal operation difficult.

**Note: Refrigerant Pipe Flushing**

Flushing removes foreign particles from the inside of pipes by means of nitrogen gas pressure.

<Three main effects>

1. Removes oxidized film inside copper pipes generated by insufficient charging of nitrogen gas during brazing.
2. Removes foreign particles and moisture that entered pipes due to inadequate preparation.
3. Confirms connection of pipes between indoor and outdoor units (for both liquid and gas pipes).

<Procedure>

1. Mount a pressure reducing valve on the nitrogen cylinder.
* Be sure to use a nitrogen gas. (Use of oxygen gas prohibited.)
2. Connect the charge hose of the pressure reducing valve to the service port of the liquid pipe of outdoor unit.
3. Mount a blind plug on indoor unit (B). Do not mount a blind plug on unit A.
4. Open the main valve of the nitrogen cylinder, and adjust the pressure reducing valve until the pressure becomes 0.5 MPa.
5. Make sure that the nitrogen gas is released through the liquid pipe of unit A.
6. Flushing
 - Close the pipe end with the palm of the hand.
 - When the pressure becomes high, move the hand quickly.
(1st flushing)
 - Close the pipe end with the palm of the hand again.
(Conduct the 2nd flushing.)

* During the flushing process, place a clean cloth at the pipe end, and check the content and amount of the removed foreign particles. If even a small amount of moisture is found, be sure to remove all moisture from inside the pipe.

Procedure

- (1) Conduct flushing using a nitrogen gas (until no moisture comes out).
- (2) Conduct vacuum drying.

7. Close the main valve of the nitrogen cylinder.
8. Repeat the same procedure for unit B.
9. After completing the flushing for the liquid pipes, conduct flushing for the gas pipes.

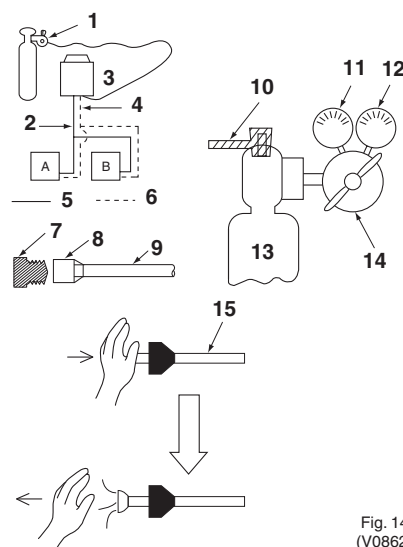

Fig. 14
(V0862)

- The pressure regulator for the nitrogen released when doing the brazing should be set to 0.02 MPa (0.2 kg/cm²) or less.

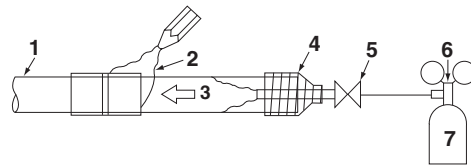

Fig. 15
(V0863)

1. Refrigerant piping
2. Location to be brazed
3. Nitrogen
4. Taping
5. Manual valve
6. Regulator
7. Nitrogen

6. Protection against Contamination when Installing Pipes

- Take measures to prevent foreign materials like moisture and contamination from mixing into the system.

Place	Installation Period	Protection Method
Outdoor	More than a month	Pinch the pipe
	Less than a month	Pinch or tape the pipe
Indoor	Regardless of the period	

- Great caution is needed when passing copper tubes through walls.

6.4 Leak Test and Vacuum Drying

The units were checked for leaks by the manufacturer.

Confirm that the valves are firmly closed before pressure test or vacuuming.

Air Tight Test and Vacuum Drying

- Air tight test: Make sure to use nitrogen gas.
Pressurize the liquid and gas pipes to 3.2MPa (do not pressurize more than 3.2MPa). If the pressure does not drop within 24 hours, the system passes the test. If the pressure drops, check where the nitrogen leaks from.
- Vacuum drying: Use a vacuum pump which can evacuate to -100.7kPa (5Torr, -755mmHg).
1. Evacuate the system from the liquid and gas pipes by using a vacuum pump for more than 2 hours and bring the system to -100.7kPa . After keeping the system under that condition for more than 1 hour, check if the vacuum gauge rises or not. If it rises, the system may either contain moisture inside or have leaks.
2. Following should be executed if there is a possibility of moisture remaining inside the pipe (if piping work is carried out during the raining season or over a long period of time rainwater may enter the pipe during work).
After evacuating the system for 2 hours, pressurize the system to 0.05MPa (vacuum break) with nitrogen gas and evacuate the system again using the vacuum pump for 1 hour to -100.7kPa (vacuum drying). If the system cannot be evacuated to -100.7kPa within 2 hours, repeat the operation of vacuum break and vacuum drying.
Then, after leaving the system in vacuum for 1 hour, confirm that the vacuum gauge does not rise.

When conducting an airtightness test

RSXYP16,18,20

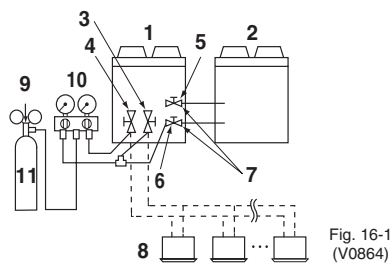

- | | |
|----------------------|------------------------------------|
| 1. RXYP (Main unit) | 7. Connecting valve (Service port) |
| 2. RXEP (Sub unit) | 8. Indoor units |
| 3. Gas side valve | 9. Regulator |
| 4. Liquid side valve | 10. Gauge manifold |
| 5. Liquid side | 11. Nitrogen |
| 6. Gas side | |

RSXYP24,26,28,30

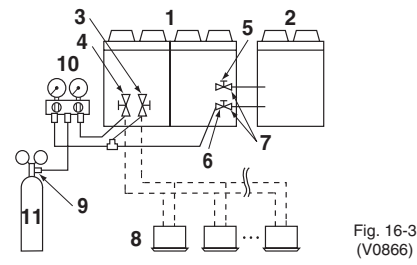

- | | |
|----------------------|------------------------------------|
| 1. RXYP (Main unit) | 7. Connecting valve (Service port) |
| 2. RXEP (Sub unit) | 8. Indoor units |
| 3. Gas side valve | 9. Regulator |
| 4. Liquid side valve | 10. Gauge manifold |
| 5. Liquid side | 11. Nitrogen |
| 6. Gas side | |

When vacuum drying

RSXYP16,18,20

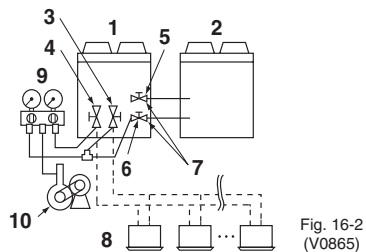

- | | |
|----------------------|------------------------------------|
| 1. RXYP (Main unit) | 6. Gas side |
| 2. RXEP (Sub unit) | 7. Connecting valve (Service port) |
| 3. Gas side valve | 8. Indoor units |
| 4. Liquid side valve | 9. Gauge manifold |
| 5. Liquid side | 10. Vacuum pump |

RSXYP24,26,28,30

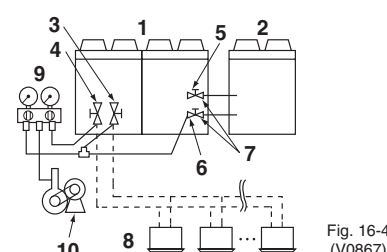

- | | |
|----------------------|------------------------------------|
| 1. RXYP (Main unit) | 6. Gas side |
| 2. RXEP (Sub unit) | 7. Connecting valve (Service port) |
| 3. Gas side valve | 8. Indoor units |
| 4. Liquid side valve | 9. Gauge manifold |
| 5. Liquid side | 10. Vacuum pump |

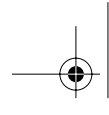

6.5 Pipe Insulation

After finishing the leak test and vacuum drying, the piping must be insulated. Take into account the following points:

- Make sure to insulate the connection piping and refrigerant branch kits entirely.
- Make sure to insulate the gas side connection piping and refrigerant branch kits entirely against heat, and depending on operation conditions (e.g. when performing cooling operation with an outside air temperature of $\leq 15^{\circ}\text{C}$), consider to also make a heat insulation of the liquid side connection piping and refrigerant branch kits to prevent dewing.
- Use heat resistant polyethylene foam which can withstand a temperature of 70°C for liquid side piping and polyethylene foam which can withstand a temperature of 120°C for gas side piping.



Caution Be sure to insulate local pipes, as touching them can cause burns.

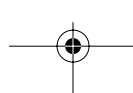

6.6 Additional Refrigerant Charge



Caution

Refrigerant may only be charged after performing the leak test and the vacuum drying. (See above.) When charging a system, care shall be taken that its maximum permissible charge is never exceeded, in view of the danger of liquid hammer. Charging with an unsuitable substance may cause explosions and accidents, so always ensure that the appropriate refrigerant (R-407C) is charged. Refrigerant containers shall be opened slowly. Always use protective gloves and protect your eyes when charging refrigerant.

- This outdoor unit is factory charged with refrigerant and depending on pipe sizes and pipe lengths some systems require additional charging of refrigerant.
- Charge the refrigerant to the liquid pipe in its liquid state. Since R-407C is a mixed refrigerant, its composition changes if charged in a state of gas and normal system operation would no longer be assured.
- Before filling, check whether the tank has a siphon attached or not.

How to fill a tank with a siphon attached.

Fill with the tank upright.
(There is a siphon tube inside, so there is no need to turn the tank upside-down.)



(V0903)

Other ways of filling the tank

Fill with the tank upside-down.



(V0904)

- Determine the weight of refrigerant to be charged additionally referring to the item "Additional refrigerant to be charged" in chapter "Example of connection". And fill in the amount in the "Request for the indication of additional refrigerant charging amount and installation date" attached to the unit.
- After the vacuum drying is finished, charge the additional refrigerant in its liquid state through the liquid stop valve service port. Taking into account following instructions:
 1. Check that gas and liquid stop valves are closed.
 2. Stop the compressor and charge the specified weight of refrigerant.
- If the outdoor unit is not in operation and the total amount cannot be charged, follow the procedures for additional refrigerant charge shown below.
- Make sure to use installation tools you exclusively use on R-407C installations to withstand the pressure and to prevent foreign materials from mixing into the system.



Notes:

- Procedure for filling added refrigerant (Connect the refrigerant charge hose as shown in the diagram in next page.)
 1. After filling the refrigerant with the outdoor unit off (always fill the tank with the unit off, and then start it up, otherwise it may break), and then turn on the indoor and outdoor power.
 2. Open up the gas side valves and valves for sub unit (both gas and liquid side).
- Be sure to close the liquid side valve. (Otherwise filling will be impossible.)
 1. Proceed to refrigerant adding mode by selecting "setting mode 2". (Refer to the "CAUTION on OPERATION" on the PCboard (A1P) on the outdoor unit for settings. Operation will not be possible immediately after power is turned on (until the LED H2P goes off: up to 12 minutes).
 2. Once the set amount of refrigerant has been filled, press the RETURN button on the A1P, and stop operation.
(It takes 30 minutes, but if filling is not completed in 30 minutes, re-set and start again.)
 3. Remove the refrigerant charge hose and be sure to **open** up the liquid side valve all the way.

RSXYP16,18,20

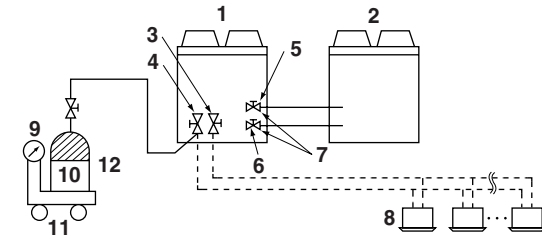

- 1. RXYP (Main unit)
- 2. RXEP (Sub unit)
- 3. Gas side valve
- 4. Liquid side valve
- 5. Liquid side
- 6. Gas side
- 7. Connecting valve (Service port)
- 8. Indoor units
- 9. R-407C
- 10. Tank
- 11. Measuring apparatus
- 12. Siphon-type

RSXYP24,26,28,30

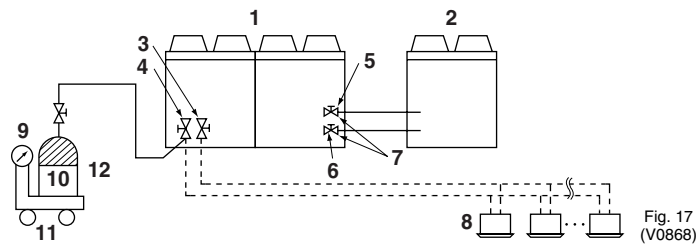
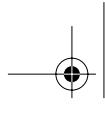

Fig. 17
(V0868)

! **Caution** If the refrigerant cylinder is siphonal, set it upright while charging additional refrigerant.



7. Field Wiring

7.1 Field Wiring



Caution

All field wiring and components must be installed and maintained by a licensed electrician and must comply with relevant local and national regulations.

The field wiring must be carried out in accordance with the wiring diagrams and the instructions given below.

Be sure to use a dedicated power circuit. Never use a power supply shared by another appliance.

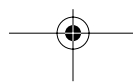
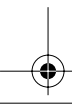
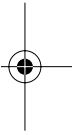
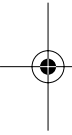

7.2 Internal Wiring

RSXYP16, 18, 20

A1P	Printed circuit board (MAIN)
A2P	Printed circuit board (INV)
A3P	Printed circuit board (SUB)
A5P	Printed circuit board
BS1-5	Push button switch (MODE, SET, RETURN, WIRING CHECK, RESET)
C1R-4R	Capacitor
C5R,6R	Capacitor
CN-1,CN-19	Relaying connector
F2C	Over current relay (M2C)
F1S	Surge Absorber
F1U,2U	Fuse (250V,10A) (A1P)
F1U	Fuse (250V,10A) (A3P)
H1P-7P	Pilotlamp (service monitor - orange) (A1P) H2P ; Prepare-flickering Malfunction detection-light up
H1P-4P	Pilotlamp (service monitor - red) (A2P)
HAP	Pilotlamp (service monitor - green) (A1P-3P)
INV	Inverter
J1HC,2HC	Crankcase heater
K1M,2M	Magnetic contactor (M1C,2C)
K1R	Magnetic relay (M1F) (A1P)
K1R	Magnetic relay (A2P)
K2R	Magnetic relay (M1F) (A1P)
K2R	Magnetic relay (A2P)
K3R	Magnetic relay (M2F) (A1P)
K4R	Magnetic relay (K2M) (A1P)
K5R	Magnetic relay (A3P)
K6R	Magnetic relay (J1HC) (A1P)
K6R	Magnetic relay (M3F) (A3P)
K7R	Magnetic relay (Y1R) (A1P)
K7R	Magnetic relay (M4F) (A3P)
K8R	Magnetic relay (Y1S) (A1P)
K9R	Magnetic relay (Y2S) (A1P)
K10R	Magnetic relay (Y3S) (A1P)
K11R	Magnetic relay (Y4S) (A1P)
K12R	Magnetic relay (Y5S) (A1P)

L1R	Reactor
M1C,2C	Motor (compressor)
MF1,2F	Motor (fan)
MF3,4F	Motor (fan)
Q1M,2M	Thermo switch (M1F, M2F)
Q3M,4M	Thermo switch (M3F, M4F)
R1	Resistor
R66-69	Resistor
R93,94	Resistor
R1T	Thermistor (AIR) (A1P)
R1T	Thermistor (FIN) (A2P)
R2-1T,2T	Thermistor (coil)
R3-1T,2T	Thermistor (discharge)
R4-1T,2T	Thermistor (header)
R6-1T	Thermistor (suction)
SENP	Pressure sensor (high)
SENPL	Pressure sensor (low)
S1PH,2PH	Pressure switch (high)
TB1,2	Terminal circuit board (relay)
T1R,2R	Transformer (220-240V/22V)
X1M	Terminal strip (power)
X2M	Terminal strip (control)
Y1E,2E	Electronic expansion valve
Y1R	4 way valve
Y1S	Solenoid valve (auxiliary condenser)
Y2S	Solenoid valve (hotgas)
Y3S	Solenoid valve (injection M1C)
Y4S	Solenoid valve (injection M2C)
Y5S	Solenoid valve (receiver)
Z1F-5F	Noise filter
(D M)	Diode module
(P C)	Power circuit
(P M)	Power module
(PRC)	Phase reversal detect circuit
(S D)	Safety devices input



Refer "Wiring diagram" for outdoor unit on page 113.

RSXYP24, 26, 28, 30

A1P	Printed circuit board (MAIN)
A2P	Printed circuit board (INV)
A3P,4P	Printed circuit board (SUB)
A5P	Printed circuit board
BS1-5	Push button switch (MODE, SET, RETURN, WIRING CHECK, RESET)
C11R,12R	Capacitor
C21R,22R	Capacitor
C3R,4R	Capacitor
C5R,6R	Capacitor
CN-1,CN-19	Relaying connector
F1S	Surge Absorber
F2C,3C	Over current relay (M2C,3C)
F1U,2U	Fuse (250V,10A) (A1P)
F1U	Fuse (250V,10A) (A3P,4P)
H1P-7P	Pilotlamp (service monitor - orange) (A1P) H2P ; Prepare-flickering Malfunction detection-light up
H1P-4P	Pilotlamp (service monitor - red) (A2P)
HAP	Pilotlamp (service monitor - green) (A1P-4P)
INV	Inverter
J1HC-3C	Crankcase heater
K1M,3M	Magnetic contactor (M1C,2C,3C)
K1R	Magnetic relay (M11F) (A1P)
K1R	Magnetic relay (A2P)
K1R	Magnetic relay (Y6S) (A3P)
K2R	Magnetic relay (M11F) (A1P)
K2R	Magnetic relay (A2P)
K3R	Magnetic relay (M12F) (A1P)
K4R	Magnetic relay (K2M) (A1P)
K5R	Magnetic relay (K3M) (A1P)
K5R	Magnetic relay (A3P,A4P)
K6R	Magnetic relay (J1HC) (A1P)
K6R	Magnetic relay (M21F) (A3P)
K6R	Magnetic relay (M3F) (A4P)
K7R	Magnetic relay (Y1R) (A1P)
K7R	Magnetic relay (M22F) (A3P)
K7R	Magnetic relay (M4F) (A4P)
K8R	Magnetic relay (Y1S) (A1P)
K9R	Magnetic relay (Y2S) (A1P)
K10R	Magnetic relay (Y3S) (A1P)
K11R	Magnetic relay (Y4S) (A1P)
K12R	Magnetic relay (Y5S) (A1P)
L1R	Reactor
M1C,2C,3C	Motor (compressor)
MF11,12F	Motor (fan)
MF21,22F	Motor (fan)
MF3,4F	Motor (fan)

Q11M,12M	Thermo switch (M11F, M12F)		
Q21M,22M	Thermo switch (M21F, M22F)		
Q3M,4M	Thermo switch (M3F, M4F)		
R1	Resistor		
R66-69	Resistor		
R93,94	Resistor		
R1T	Thermistor (AIR) (A1P)		
R1T	Thermistor (FIN) (A2P)		
R2-11T,12T	Thermistor (coil)		
R2-2T	Thermistor (coil)		
R3-11T-13T	Thermistor (discharge)		
R4-11T-13T	Thermistor (header)		
R6-1T	Thermistor (suction)		
SENP	Pressure sensor (high)		
SENPL	Pressure sensor (low)		
S1PH-3PH	Pressure switch (high)		
TB1,2	Terminal circuit board (relay)		
T1R,2R	Transformer (220-240V/22V)		
X1M	Terminal strip (power)		
X2M	Terminal strip (control)		
X3M	Terminal strip (relay)		
Y1E-3E	Electronic expansion valve		
Y1R	4 way valve		
Y1S	Solenoid valve (auxiliary condenser)		
Y2S	Solenoid valve (hotgas)		
Y3S	Solenoid valve (injection M1C)		
Y4S	Solenoid valve (injection M2C)		
Y5S	Solenoid valve (receiver)		
Y6S	Solenoid valve (injection M3C)		
Z1F-6F	Noise filter(surge absorber)		
(D M)	Diode module		
(P C)	Power circuit		
(P M)	Power module		
(PRC)	Phase reversal detect circuit		
(S D)	Safety devices input		
■ ■ ■ ■	Field wiring		
L1,L2,L3	Live		
N	Neutral		
□ □	Connector		
○	Wire clamp		
⊕	Protective earth (screw)		
Colours	BLK : Black BLU : Blue BRN : Brown	GRY : Gray ORG : Orange PNK : Pink	RED : Red WHT : White YLW : Yellow

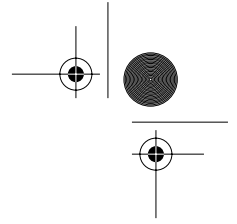

7.3 Optional Parts Cool/Heat Selector

SS1 Selector switch (fan, cool/heat)
SS2 Selector switch (cool/heat)



Notes:

- Use copper conductors only.
- When using the adaptor for sequential start, refer to chapter "Examples".
- For connection wiring to outdoor-outdoor transmission F1-F2, outdoor-indoor transmission F1-F2, refer to chapter "Examples".
- For connection wiring to the central remote control, refer to the installation manual of the central remote control.
- Use insulated wire for the power cord.

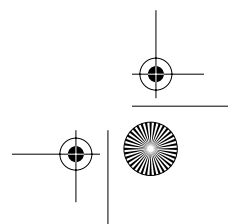
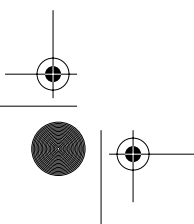
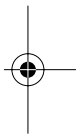



7.4 Power Circuit and Cable Requirements

A power circuit (See table below) must be provided for connection of the unit. This circuit must be protected with the required safety devices, i.e. a main switch, a slow blow fuse on each phase and an earth leak detector.

	Phase and Frequency	Voltage	Recommended Fuses	Transmission Line Selection
RSXYP16	3N~50Hz	380-415V	45A	0.75-1.25mm ²
RSXYP18	3N~50Hz	380-415V	50A	0.75-1.25mm ²
RSXYP20	3N~50Hz	380-415V	60A	0.75-1.25mm ²
RSXYP24	3N~50Hz	380-415V	60A	0.75-1.25mm ²
RSXYP26	3N~50Hz	380-415V	70A	0.75-1.25mm ²
RSXYP28	3N~50Hz	380-415V	70A	0.75-1.25mm ²
RSXYP30	3N~50Hz	380-415V	70A	0.75-1.25mm ²

When using residual current operated circuit breakers, be sure to use a high-speed type 200mA rated residual operating current.



Note: Select the power supply cable in accordance with relevant local and national regulations.

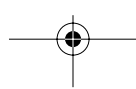
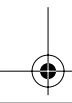
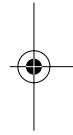
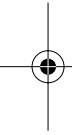

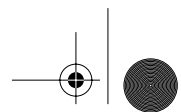

7.5 General

- Make sure to connect the power source wire to the power source terminal block and to clamp it as shown in figure 19, chapter "Field line connection".
- As this unit is equipped with an inverter, installing a phase advancing capacitor not only will deteriorate power factor improvement effect, but also may cause capacitor abnormal heating accident due to high-frequency waves. Therefore, never install a phase advancing capacitor.
- Keep power imbalance within 2% of the supply rating.
 1. Large imbalance will shorten the life of the smoothing capacitor.
 2. As a protective measure, the product will stop operating and an error indication will be made, when power imbalance exceeds 4% of the supply rating.
- Follow the "electrical wiring diagram" when carrying out any electrical wiring.
- Only proceed with wiring work after blocking off all power.
- Always ground wires. (In accordance with national regulations of the pertinent country.)
- Do not connect the ground wire to gas pipes, sewage pipes, lightning rods, or telephone ground wires.

Gas pipes: can explode or catch fire if there is a gas leak.
Sewage pipes: no grounding effect is possible if hard plastic piping is used.
Telephone ground wires and lightning rods: dangerous when struck by lightning due to abnormal rise in electrical potential in the grounding.
- This unit uses an inverter, and therefore generates noise, which will have to be reduced to avoid interfering with other devices. The outer casing of the product may take on an electrical charge due to leaked electrical current, which will have to be discharged with the grounding.
- Be sure to install an earth leak detector. (One that can handle higher harmonics.)
(This unit uses an inverter, which means that an earth leak detector capable handling high harmonics in order to prevent malfunctioning of the earth leak detector itself.)
- Earth leak detector which are especially for protecting ground-faults should be used in conjunction with main switch or fuse for use with wiring.
- This unit has a negative phase protection circuit. (If it operates, only operate the unit after correcting the wiring.)

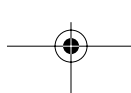

7.6 Examples

7.6.1 System Example

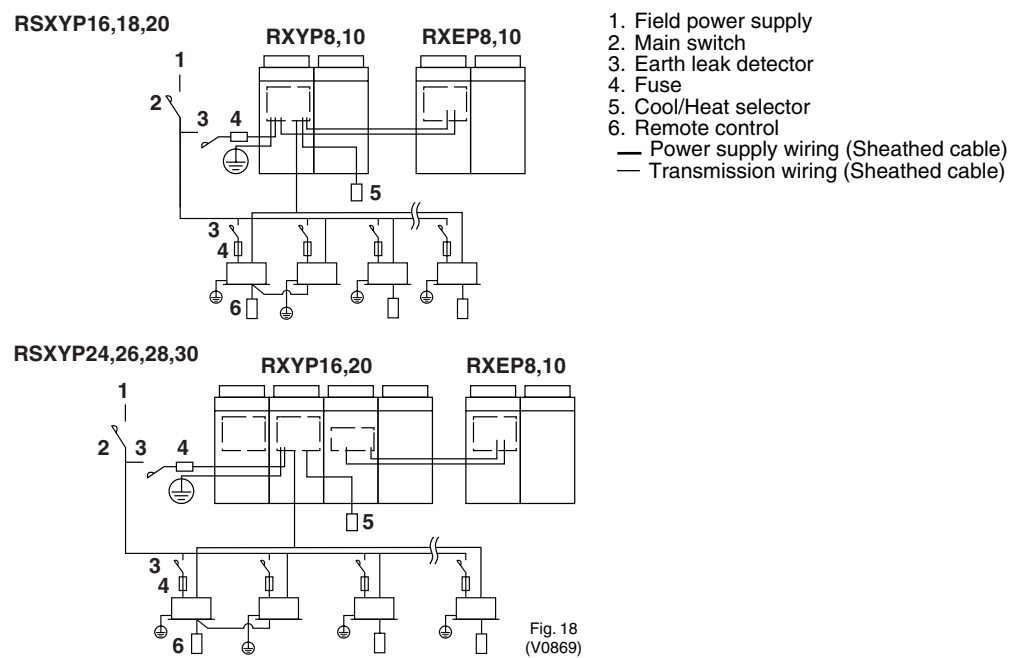

7.6.2 Field Line Connection

L1, L2, L3, N-phase of the power cord should be clamped to the safety catch using the included clamp material.

The green and yellow striped wrapped wires should be used for grounding.

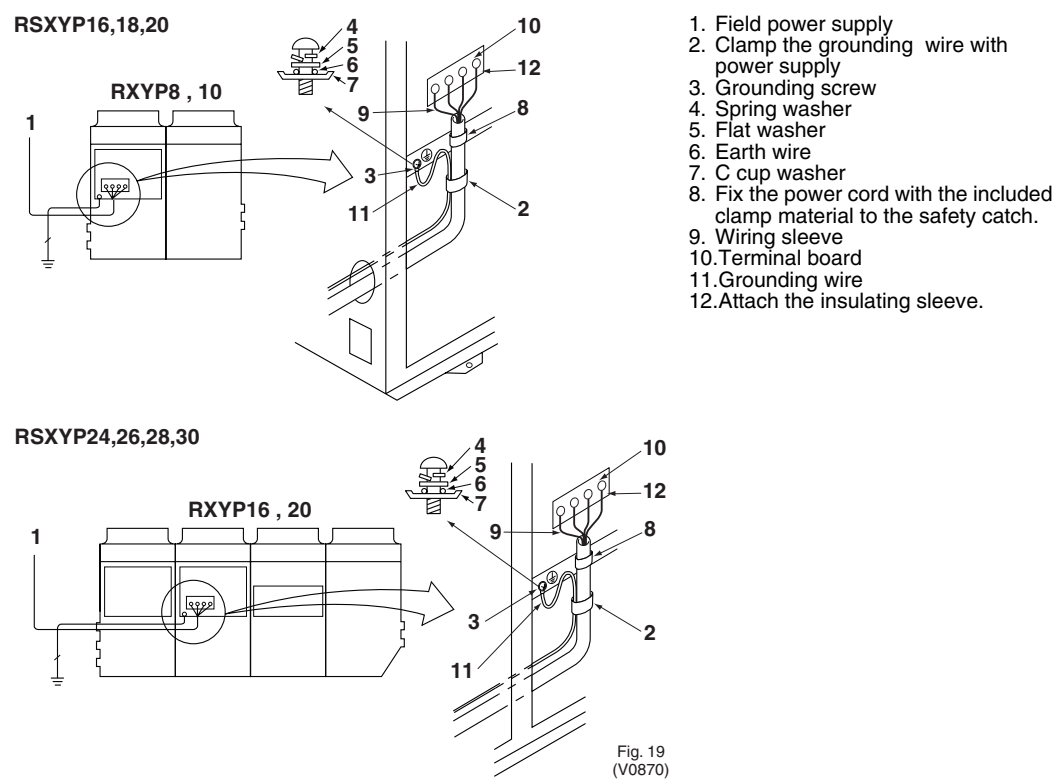

7.6.3 Field Line Connection between Main Unit (RXYP-) and Sub Unit (RXEP-)



Caution In the event that the main unit and the sub unit are separated by 1000 mm or more, the attached cables cannot be used. The wiring between the outdoor units should be connected by extending the attached cable using the included connectors. The connector must be wired to be inside the switch box.

RSXYP16,18,20

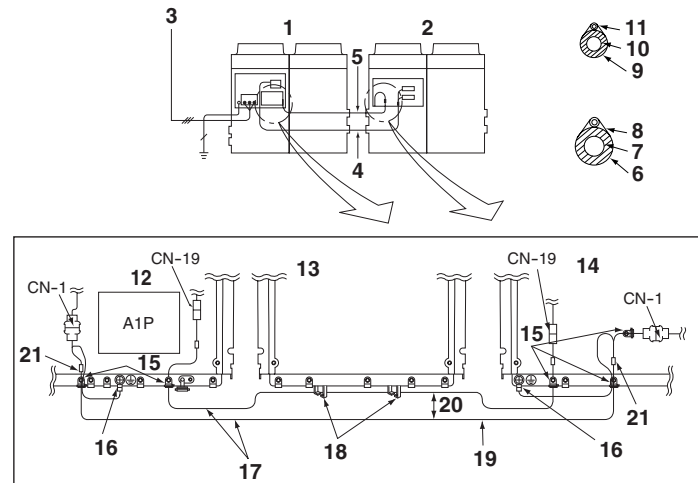

Fig. 20-1
(V0871)

1. RXYP8,10 (Main unit)
2. RXEP8,10 (Sub unit)
3. Power supply
4. Branch wiring between outdoor units (High voltage)
5. Branch wiring between outdoor units (Low voltage)
6. Insulation material
7. Gas line
8. Cable (High voltage)
9. Insulation material
10. Liquid line
11. Cable (Low voltage)
12. RXYP (Main unit) switch box
13. RXYP (Main unit) inverter box
14. RXEP (Sub-unit)
15. Fix to the safety catch.
16. Connect the ground wire (green/yellow) to the ground terminal
17. Extended wiring (7000 mm or less) (Sheathed cable or 0.75 mm² cables)
18. Divide the low voltage wire from the high voltage wire using the wire clip on the bottom of the inverter box
19. Always separate the high voltage wiring from the low voltage wiring in the branch wiring
20. 30 mm or more
21. Connection binder

RSXYP24,26,28,30

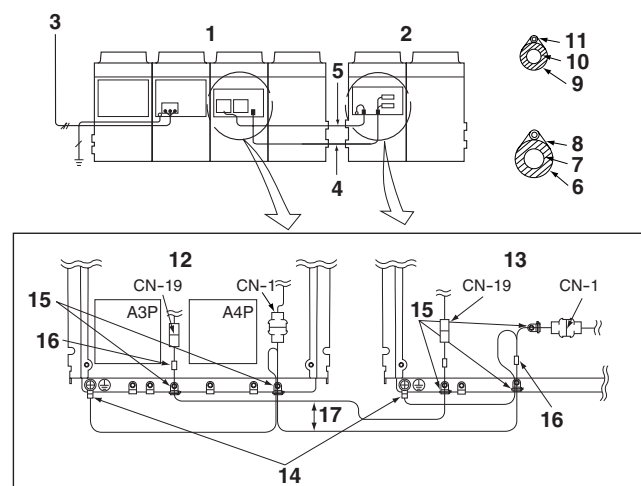
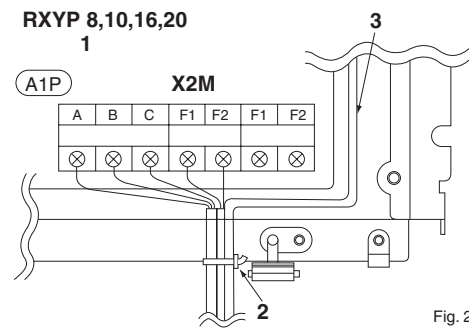

Fig. 20-2
(V0872)

1. RXYP16,20 (Main unit)
2. RXEP8,10 (Sub unit)
3. Power supply
4. Branch wiring between outdoor units (High voltage)
5. Branch wiring between outdoor units (Low voltage)
6. Insulation material
7. Gas line
8. Cable (High voltage)
9. Insulation material
10. Liquid line
11. Cable (Low voltage)
12. RXYP (Main unit) switch box
13. RXEP (Sub-unit) switch box
14. Connect the ground wire (green/yellow) to the ground terminal extended wiring (7000 mm or less) (Sheathed cable or 0.75 mm² cables)
- Always separate the high voltage wiring from the low voltage wiring in the branch wiring
15. Fix to safety catch
16. Connection binder
17. 30mm or more

7.6.4 Field Line Connection : Transmission Wiring and Cool/Heat Selection

Fig. 21
(V0873)

1. Switch box (Main unit)
2. Fix to the safety catch using the attached clamp material
3. Attached cable (between main and sub units)

7.6.5 Example of Performing Cool/Heat with Cool/Heat Selector

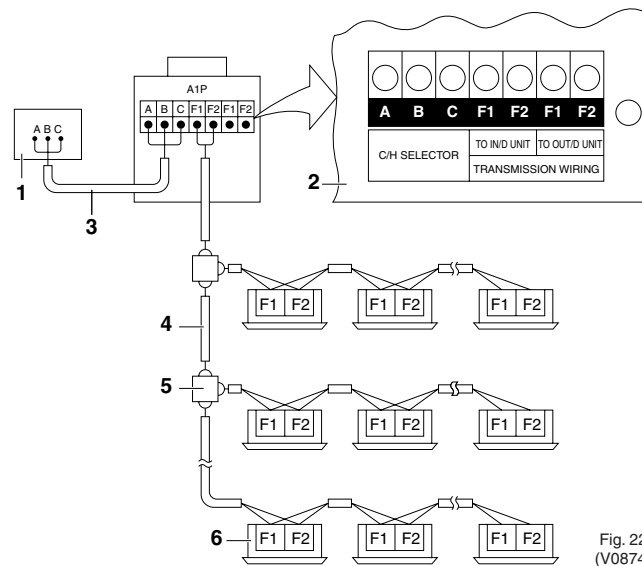
Fig. 22
(V0874)

1. Cool/Heat selector (optional for heat pump unit only)
2. Outdoor unit P.C. Board (A1P)
3. Take care of the polarity
4. Use the conductor of sheathed wire (2 wire) (no polarity)
5. Terminal board (Field supply)
6. Indoor unit

7.6.6 Example of Performing Cool/Heat Setting of Two or More Outdoor Units in Block with Cool/Heat Selector

- For the wiring shown in figure 22, be sure to use 0.75-1.25 mm² vinyl cords with sheath or cables (two-core). (Three-core cables can be used only for the cool/heat selector.) (Insulated thickness : 1mm or more)
- The wires shown in figure 22 are field supply.



Caution

Be sure to follow the limits below. If the unit-to-unit cables are beyond these limits, it may result in malfunction of transmission.

Maximum wiring length: 1000m

Total wiring length: 2000m

Max branches No. of branches: 16

Up to 16 branches are possible for unit-to unit cabling. No branching is allowed after branching.

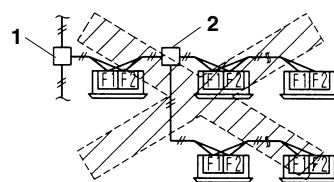
Fig. 23
(V0875)

1. Branch
2. Subbranching

Never connect the power supply to unit-to-unit cabling terminal block. Otherwise the entire system may break down.

7.6.7 Sequential Start

Make the outdoor unit cable connections shown below.

The outdoor unit PC board (A1P) is factory set at "Sequential start available".

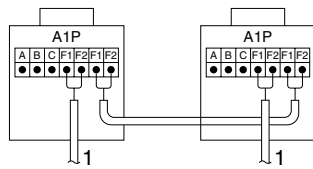
Fig. 24
(V0876)

1. Indoor unit

7.6.8 Setting the Cool/Heat Operation

1. Performing cool/heat setting with the remote control connected to the indoor unit.

Keep the cool/heat selector switch (SS1) on the outdoor unit PC board (A1P) at the factory setting position IN/D UNIT.

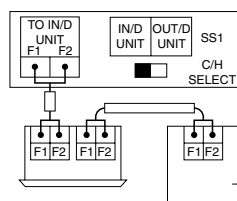
Fig. 25
(V0877)

1. Remote control

2. Performing cool/heat setting with the cool/heat selector.

Connect the cool/heat selector remote control (optional) to the A/B/C terminals and set the cool/heat selector switch (SS1) on the outdoor unit PC board (A1P) to OUT/D UNIT.

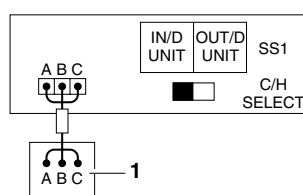
Fig. 26
(V0878)

1. Cool/Heat selector



Caution

For low-noise operation, it is necessary to get the optional "External control adaptor for outdoor unit". For details, see the installation manual attached to the adaptor or service manual Si33-002.

7.6.9 Picking Power Line and Transmission Line

- Be sure to let the power line and the transmission line pass through a conduit hole.
- Pick the power line from the upper hole on the left side plate, from the front position of the main unit (through the conduit hole of the wiring mounting plate - optional parts) or from a knock out hole to be made in the unit's bottom plate.

RXYP16,18,20

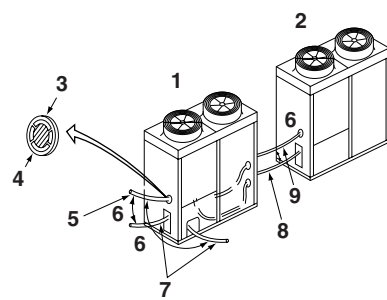
Fig. 27-1
(V0879)

1. RXYP8,10 (Main unit)
2. RXEP8,10 (Sub unit)
3. Through -slot cover
4. Cut out the diagonal line area
5. Power cord
6. Separate
7. Branch wiring between indoor and outdoor units.
8. Branch wiring between outdoor units (High voltage)
9. Branch wiring between outdoor units (Low voltage)
10. Cable (Low voltage)
11. Liquid line
12. Insulation material
13. Cable (High voltage)
14. Gas line
15. Insulation material

RXYP24,26,28,30

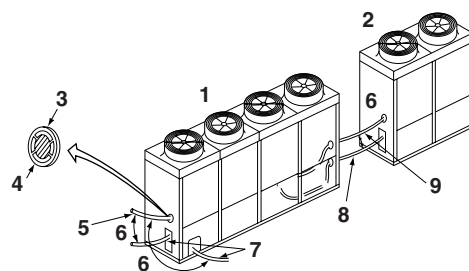
Fig. 27-2
(V0880)

1. RXYP16,20 (Main unit)
- 2-15. Same as RXYP16,18,20

- If you pick the power line from the front position of the unit, proceed as follows and refer to figure 28:

- Remove the lower frontplate (1), punch a hole in the knock hole and cut the hole (2) all the way to the slit.
- Attach the 3 sealing pads (optional parts) (3) on the wiring mounting plate (optional parts) (4) corresponding to the overlapped area of the front plate.
- Install the wiring mounting plate to the front side of the side plate with the 2 delivered screws.

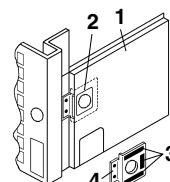
Fig. 28
(V0881)

- Pick the transmission line from the middle positioned conduit hole on the left side plate, or from the front position of the main unit (after binding it to the piping with finishing tape as in figure 29).

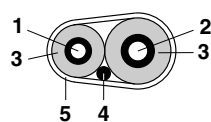
Fig. 29
(V0882)

1. Liquid side pipe
2. Gas side pipe
3. Pipe heat insulation
4. Transmission line
5. Finishing tape



Caution

Be sure to keep the power line and transmission line apart from each other.

Be careful about polarity of the transmission line.

Make sure that the transmission line is clamped as shown in the figure in chapter "Field line connection".

Check that wiring lines do not make contact with refrigerant piping.

Firmly close the lid and arrange the electrical wires so as to prevent the lid or other parts from coming loose.

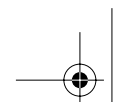

8. Before Operation

8.1 Checks before Initial Start-Up



Caution Make sure that the circuit breaker on the power supply panel of the installation is switched off.

After the installation, check the following before switching on the circuit breaker:

1. The position of the switches that require an initial setting

Make sure that switches are set according to your application needs before turning the power supply on.

2. Power supply wiring and transmission wiring

Use a designated power supply and transmission wiring and make sure that it has been carried out according to the instructions described in this manual, according to the wiring diagrams and according to local and national regulations.

3. Pipe sizes and pipe insulation

Make sure that correct pipe sizes are installed and that the insulation work is properly executed.

4. Additional refrigerant charge

Keep record of the additional refrigerant charged by filling it out on the sticker on the rear of the upper front panel.

5. Insulation test of the main power circuit

Using a megatester for 500V, check that the insulation resistance of 2M Ω or more is attained by applying a voltage of 500V DC between power terminals and earth. Never use the megatester for the transmission wiring.

6. Installation date

Be sure to keep record of the installation date on the sticker on the rear of the upper front panel according to EN60335-2-40.

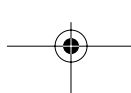

8.2 Test Run

8.2.1 Operation of Stop Valve

Keep all stop valves fully open. (Refer to chapter "How to operate stop valves".)

8.2.2 Power Supply Connection



Caution

In order to avoid compressor damage, it is necessary to switch on the crankcase heater for **at least six hours** before starting the compressor after a long period of standstill or for the first time.

Set all the initial settings for the test run with the power on. Be careful not to touch, under any circumstances, any button other than the push button switches (BS1-5) on the PCB(XIA) when making settings. Doing so can cause electrical shocks.

- To switch on the crankcase heater, turn on the circuit breaker.
- Set the LED on the outdoor unit PC board after turning on the circuit breaker.
- Before switching on the indoor unit(s), refer to the operation manual of the corresponding unit(s) for more details.
- Turn on the switch to indoor unit(s).
- The test run must be performed starting with cooling operation.
Start this operation about 8 minutes after turning on the indoor unit and outdoor unit power.



Note:

- Do not try to get started with the remote control just after turning on the power. The remote control shows "UH" and the system fails to start.
When the outdoor temperature is below -5°C , perform the testrun in heating mode.

8.2.3 Operation Check - Temperature Regulating Operation Check

1. Perform the cross wiring - cross piping check as described in "CAUTIONS ON OPERATION" attached on the rear of the upper front panel.
2. Set the unit to "❄" mode using the cool/heat selector (heatpump units only) or the indoor remote control.
3. Press the "TEST" button 4 times to set the unit to "TEST" mode operation. ("TEST" is displayed.) Pressing the "TEST" button 5 times will make the unit return to its normal operation mode.
4. Within 10minutes after having set the unit to test mode, press the "ON" button to start the test operation. Check if the indoor and outdoor units are operating normally. If, due to compressor liquid compression, a knocking noise is heard, stop the unit immediately and start it again after a while. The test run will be stopped automatically after 30 minutes.
5. Press the "ON" button to stop the unit.
6. Perform normal operation. Refer to the operation manual of the corresponding indoor unit(s) for details.
 - Check that cool air (or hot, in case of heating operation of heatpump units) is blown from the indoor unit.
 - Operate each indoor unit individually and check whether the corresponding outdoor unit is running.



Caution

Blinking of the remote control operation lamp means that an error occurred. The error code is displayed in the liquid crystal display and the relation between error codes and their meaning is shown in "CAUTIONS IN SERVICING" attached to the indoor unit.

The compressor is protected by a guard timer and will not restart, not even if the "ON" button of a connected indoor unit is pressed, before the guard timer setting of 5 minutes elapsed.

Pump down operation cannot be executed because this would result in serious compressor damage.



Refer the "detail of error code display" to service manual Si33-002 page 123.

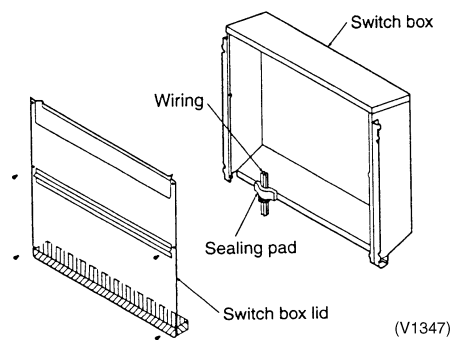

When installing the switch box lid, if there is a gap caused by the electrical wires, apply the sealing material to fill the gap to prevent bugs from entering.

Incombustibility	Equivalent to UL94HF-1
------------------	------------------------

(Choose an appropriate thickness for each location.)

8.2.4 How to Operate Stop Valves

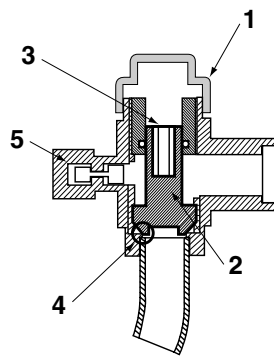

Fig. 31
(V0884)

1. To Open

1. Remove the cap (1) and turn the shaft (2) counterclockwise with hexagon socket screw keys (JIS B 4648 nominal size 6 mm and 10 mm).
2. Turn it all the way until the shaft stops.
3. Tighten the cap firmly.

2. To Close

1. Remove the cap and turn the shaft clockwise.
2. Tighten the shaft firmly until it reaches the sealed area (4) of the body.
3. Tighten the cap firmly.



Notes:

- Refer to the table at the end of this chapter for tightening torques and dimensions of the flares.
- Be sure to use both, a spanner and a torque wrench, when connecting or disconnecting pipes to or from the unit.
- When connecting a flare nut, apply ether or ester oil on the flare area (both internal and external face), and screw it with your hand a few times first.
- Use a charging hose with push rod when using the service port 5.
- Check for refrigerant gas leakage after tightening the cap.
- Make sure to apply ether oil or ester oil around the flare portions (both inner and outer face) when connecting flare nuts, and give 3 turns by hand before applying spanners.
- Make sure to keep stop valve open during operation.

FLARE SHAPE and FLARENUT TIGHTENING TORQUE

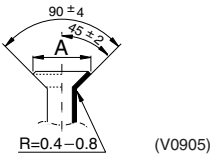
Pipe Size	Tightening Torque (N·m)	A (mm)	Flare Shape
φ6.4	14.2-17.2	8.3-8.7	
φ9.5	32.7-39.9	12.0-12.4	
φ12.7	49.5-60.3	15.4-15.8	
φ15.9	61.8-75.4	18.6-19.0	
φ19.1	97.2-118.6	22.9-23.3	

Not recommendable but in case of emergency

You must use a torque wrench but if you are obliged to install the unit without a torque wrench, you may follow the installation method mentioned below.

After the work is finished, make sure to check that there is no gas leak.

When you keep on tightening the flare nut with a spanner, there is a point where the tightening torque suddenly increases. From that position, further tighten the flare nut the angle shown below:

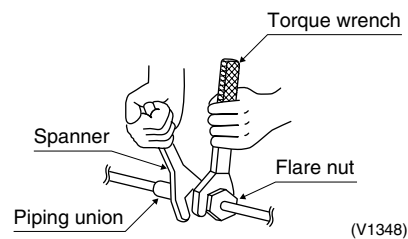

Pipe size	Further tightening angle	Recommended arm length of tool
6.4 (1/4")	60 to 90 degrees	Approx. 150mm
9.5 (3/8")	60 to 90 degrees	Approx. 200mm
12.7 (1/2")	30 to 60 degrees	Approx. 250mm
15.9 (5/8")	30 to 60 degrees	Approx. 300mm
19.1 (3/4")	20 to 35 degrees	Approx. 450mm

8.2.5 Misswiring Check Operation

(Refer to the "CAUTION ON OPERATION" on the PCB (A1P) on the outdoor unit for settings. Operation will not be possible immediately after power is turned on (until the LED H2P goes off: up to 12 minutes).

1. Use monitor mode to check the number of indoor units connected.



2. Press the "Wiring check" button for 5 seconds after returning to setting mode 1, and carry out the miswiring check operation. The LED H2P will light up during operation and go out when complete.
3. After completion of operation, wait about one minute, and then use monitor mode to check the number of indoor units connected again to see whether the number is the same as before. If it is not, the difference represents the number of indoor units whose wiring has been done incorrectly. Use the operation remote control to operate the indoor units, and correct the wiring on units which display "UF" on the remote control.

How to monitor the number of "MODE" connected indoor units.

1 Enter monitor mode by pressing the "MODE" button once.	
2 Press the "SET" button until the LEDs (H2P through H7P) are as shown at right.	
3 Pressing the "RETURN" button once will display the number of indoor units on the LED display (H2P through H7P). (Binary display: example shows 7 units.)	
4 Press the "MODE" button to return to set mode 1. (The example at right shows the status when shipped from the factory.)	

(V0909)

8.2.6 Disposal Requirements

Dismantling of the unit, treatment of the refrigerant, oil and eventual other parts, should be done in accordance with the relevant local and national regulations.

9. Caution for Refrigerant Leaks

9.1 Caution for Refrigerant Leaks

9.1.1 Introduction

The installer and system specialist shall secure safety against leakage according to local regulations or standards. The following standards may be applicable if local regulations are not available.

The VRV System, like other air conditioning systems, uses R-407C as refrigerant. R-407C itself is an entirely safe non-toxic, non-combustible refrigerant. Nevertheless care must be taken to ensure that air conditioning facilities are installed in a room which is sufficiently large. This assures that the maximum concentration level of refrigerant gas is not exceeded, in the unlikely event of major leak in the system and this in accordance to the local applicable regulations and standards.

9.1.2 Maximum Concentration Level

The maximum charge of refrigerant and the calculation of the maximum concentration of refrigerant is directly related to the humanly occupied space in to which it could leak.

The unit of measurement of the concentration is kg/m^3 (the weight in kg of the refrigerant gas in 1m^3 volume of the occupied space).

Compliance to the local applicable regulations and standards for the maximum allowable concentration level is required.

In Japan the maximum allowed concentration level of refrigerant to a humanly space for R-407C is limited to 0.3 kg/m^3

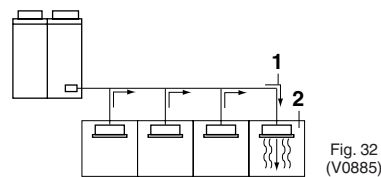

1. Direction of The Refrigerant Flow
2. Room where refrigerant leak has occurred (outflow of all the refrigerant from the system)

Pay a special attention to the place, such as a basement, etc. where refrigerant can stay, since refrigerant is heavier than air.

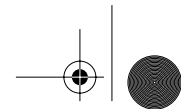
**Caution for Refrigerant Leaks****SiE33-003****9.1.3 Procedure for Checking Maximum Concentration**

Check the maximum concentration level in accordance with steps 1 to 4 below and take whatever action is necessary to comply.

Step 1

Calculate the amount of refrigerant (kg) charged to each system separately.

amount of refrigerant in a single unit system (amount of refrigerant with which the system is charged before leaving the factory)	+	additional charging amount (amount of refrigerant added locally in accordance with the length or diameter of the refrigerant piping)	=	total amount of refrigerant (kg) in the system
---	---	--	---	--



Note: ■ Where a single refrigerant facility is divided into 2 entirely independent refrigerant systems then use the amount of refrigerant with which each separate system is charged.

Step 2

Calculate the smallest room volume (m³)

In case like the following, calculate the volume of (A), (B) as a single room or as the smallest room.

A. Where there are no smaller room divisions

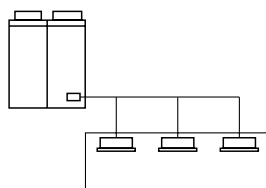
Fig. 33
(V0886)

B. Where there is a room division but there is an opening between the rooms sufficiently large to permit a free flow of air back and forth.

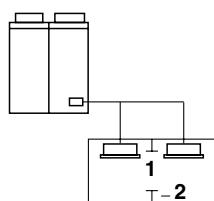

1. Opening between rooms
2. Partition

Fig. 34
(V0887)

(Where there is an opening without a door or where there are openings above and below the door which are each equivalent in size to 0.15% or more of the floor area.)

Step 3

Calculating the refrigerant density using the results of the calculations in steps 1 and 2 above.

$$\frac{\text{total volume of refrigerant in the refrigerant system}}{\text{size (m}^3\text{) of smallest room in which there is an indoor unit installed}} \leq \text{maximum concentration level (kg/m}^3\text{)}$$

If the result of the above calculation exceeds the maximum concentration level then make similar calculations for the second then third smallest room and so until the result falls short of the maximum concentration.

Step 4

Dealing with the situations where the result exceeds the maximum concentration level.

Where the installation of a facility results in a concentration in excess of the maximum concentration level then it will be necessary to revise the system.

Please consult your Daikin supplier.

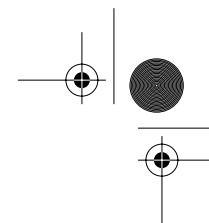

Part 3 New Refrigerant R-407C

- 1. Precautions in Servicing the Models with New-type Refrigerant..... 168
 - 1.1 Tools Required 168
 - 1.2 Notes for Work Procedures 169
- 2. Changes Required by New Refrigerants..... 170
 - 2.1 Changes Required by New Refrigerant..... 170
- 3. Refrigerant and Refrigerant Oil Characteristics 171
 - 3.1 Refrigerant Characteristics 171
 - 3.2 Refrigerant Oil Characteristics..... 173
- 4. Refrigerant Cylinders 174
 - 4.1 Cylinder Specifications 174
 - 4.2 Handling of Cylinders 175
- 5. Service Tools 176
 - 5.1 Tool Compatibility 176
 - 5.2 New Tools Required for HFCs and Reasons of Change..... 177
- 6. Cautions During Service Operations
(Changes Required by New Refrigerants) 180
 - 6.1 The Three Basic Rules for Refrigerant Piping
Must Be More Strictly Observed..... 180
- 7. Operation Guideline 181
 - 7.1 Operation Guideline..... 181
- 8. Temperature-pressure Conversion Table for New Refrigerants 182
 - 8.1 Pressure and Temperature..... 182
- 9. Measures to Take in the Case of Gas Leaks 183
 - 9.1 Gas Shortage 183
 - 9.2 Measure for Gas Shortage 184
- 10. Safety Precautions 185
 - 10.1 Safety Precautions 185
- 11. Problems Resulting from Negligence of Caution Items..... 186
 - 11.1 Problems Resulting from Negligence of Caution Items..... 186
- 12. Difference Between Pascal and Conventional Pressure Unit 187
 - 12.1 Comparison of MPa and kgf/cm²..... 187
- 13. Thermodynamic Characteristic Charts (HFC407C) 188
 - 13.1 Thermodynamic Characteristics of R-407C..... 188

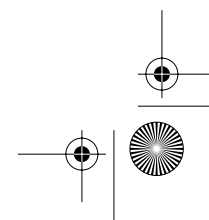
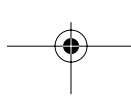
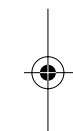
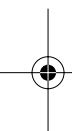

1. Precautions in Servicing the Models with New-type Refrigerant

Compared to the conventional refrigerant R22, the brand-new refrigerant R-407C is higher in pressure. The refrigerant oil is also different in type. With this in mind, note that the piping work procedures as well as the related tools and piping materials are partially different than ever before.

Refrigerant	Conventional type	New type
	R22 (single)	R-407C (mixed)
Refrigerant oil	Mineral oil (Suniso)	Synthetic oil (ether)
Condensation pressure	1.84MPa	2.01MPa

1.1 Tools Required

Some specific tools are required for servicing the refrigerant line of the new-type refrigerant models. Select the right tools referring to the table below.

Typical tools and materials for piping works and their interchangeability

Name	Work process and application		Interchangeability with conventional tools and materials
Pipe cutter	Refrigerant piping work	Cutting pipes	Interchangeable.
Flaring tool		Flaring pipes	
Refrigerant oil		Applying on flared spots	Specified ether oil, ester oil, alkyl benzene oil or their mixture to be used.
Torque wrench		Connecting flare nut	Interchangeable.
Pipe expander		Expanding pipes at connections	
Pipe bender		Bending pipes	
Nitrogen	Air-tightness test	Inhibiting oxidation in pipes	
Welder		Brazing pipes	
Gauge manifold	Air-tightness test thru refrigerant recharging	Vacuum refrigerant charging and running test	Specific tools required for boosting the pressure and preventing impurities from coming in.
Charging hose			
Vacuum pump	Vacuum drying		Interchangeable. (Adapter to be connected to keep the oil from flowing back to the unit during pump shut-down. Pump with anti-backflow function also available.)
Charging cylinder	Refrigerant recharging		Conventional cylinder not allowed because of different refrigerant properties. (Need to weigh with the scale.)
Refrigerant charging scale			Interchangeable.
Gas leak detector		Gas leak test	Specific detector needed. (R134a-compatible detector allowed.)

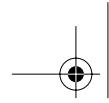

1.2 Notes for Work Procedures

Brazing connections

- With the new type of refrigerant, much more care must be paid to keep impurities from coming in. In brazing the pipes, be sure to blow the pipe using nitrogen gas.
- In any other connecting works, much stricter process control is needed to prevent impurities from coming into the pipes. For this purpose, take appropriate measures such as covering the pipes and do the vacuum drying.

Flaring work

- Chamfer (file) the pipe ends as specified. Be very careful not to allow cuttings to come into the pipes.
- To avoid leak, apply a proper amount of refrigerant oil over the inner and outer surfaces of each flared section. As the refrigerant oil, be sure to use synthetic oil (ether oil, ester oil, alkyl benzene oil or their mixture).

Charging refrigerant

- Be sure to charge the new-type refrigerant in liquid phase via the service port of the liquid-side stop valve (outdoor unit). At this time, give vacuum drying with a vacuum pump. Never try the air purging.

Air-tightness test

- Be sure to conduct air-tightness test.



Caution

For servicing the models with the new-type refrigerant, strictly follow the above instructions and precautions. Otherwise the system may get in trouble. For details on handling the new-type refrigerant and the related work procedures and tools, refer to the Installation/Test Run Manual published by Daikin.

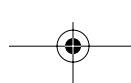
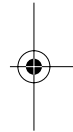
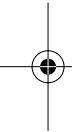

2. Changes Required by New Refrigerants

2.1 Changes Required by New Refrigerant

The following two types of refrigerant are being used in place of the HCFC22 (R22) refrigerant. Main differences in specification are pressure difference (higher) and compatible refrigerant oil type.

	HFC units (Units using new refrigerants)	HCFC units
Refrigerant name	R-407C	R22
Main application	Packaged air conditioners	Room air conditioners Packaged air conditioners
Composing substances	Non-azeotropic mixture★1 of HFC32, HFC125 and HFC134a	Single-component refrigerant
Design pressure	3.2MPa (gauge pressure)=32.6kgf/cm ²	2.75Mpa(gauge pressure)=28.0kgf/cm ²
Refrigerant oil	Synthetic oil (ether)	Mineral oil (suniso)
Ozone destruction factor (ODP)	0	0.05
Combustibility	None	None
Toxicity	None	None

★1 Non-azeotropic mixture refrigerant ; mixture of two or more refrigerants having different boiling points.



1Mpa : Approx. 10.19716kgf/cm²

3. Refrigerant and Refrigerant Oil Characteristics

3.1 Refrigerant Characteristics

Main characteristics of R-407C and R410A refrigerants are shown in the following table.

	R-407C	R22
Chemical formula	$\text{CH}_2\text{F}_2/\text{C}_2\text{HF}_5/\text{CH}_2\text{FCF}_3$	CHClF_2
Composition (mixing ratio, wt%)	HFC32/125/134a (23/25/52)	
Boiling point (°C)	-43.6 ★4	-40.8
ODP ★1	0	0.05
GWP ★1	1530	1700
Pressure ★2 (physical characteristic)	110 ★4	100
Capacity ★3 (physical characteristic)	98	100
COP ★3 (physical characteristic)	95	100
Azeotropy/ non-azeotropy	Non-azeotropic	(Single component)
Flammability	Nonflammable	Nonflammable
Evaluation (comparison with R22)	Pressure is approximately 10% higher than that of R22. Capacity is about the same. Since it is non-azeotropic, it must be handled with utmost caution. (Mishandling causes the composition to change.)	

★1. ODP (ozone destruction factor) : Indicated values are relative value with that of R11 as 1.

GWP (global warming factor) : indicated values are relative value with that of CO₂ as 1.

★2. Temperature condition : 50°C

★3. Temperature condition : 0/50°C

★4. Boiling point condition : Temperatures at which R-407C begin boiling under the atmospheric pressure (1 atm)

R407C characteristics

- * Pressure characteristic is approximately 10% higher than that of R22.
- * Non-azeotropic refrigerant of two or more refrigerant types.
- * Does not damage the ozone layer (ODP: 0).
- * Does not contain chlorine.

Refrigerant characteristics

- * Lower lubricating performance due to the absence of chlorine.
- * Lower oil returning performance due to the incompatibility with mineral oil (suniso).

Due to the above characteristics, the following oil is selected as chiller oil.

Ether oil

(V1106)



Change of Composition and Characteristic in Refrigerant

The following chart shows the relationship between the composition balance (mixing ratio by weight) and characteristics (pressure, combustibility, GWP, COP).

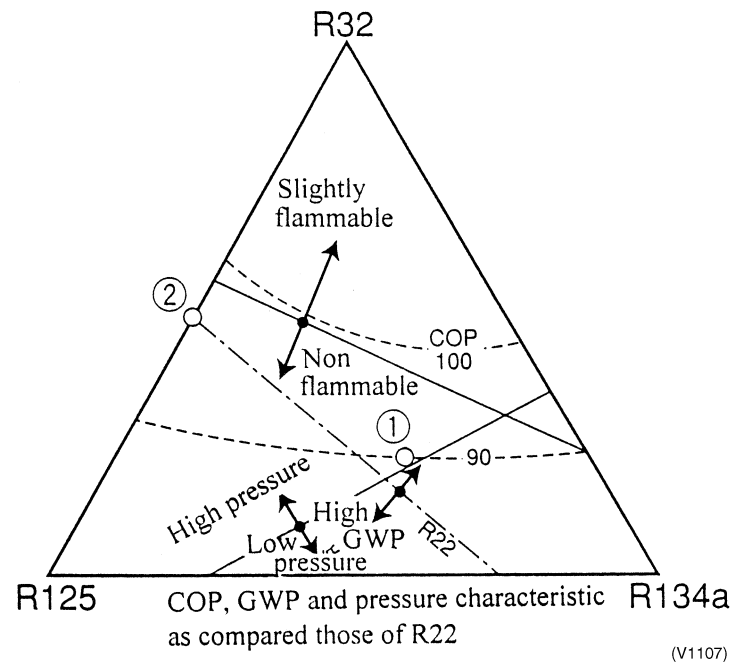

Note: R-407C [R32/R125/R134a (23/25/52wt%)]

When the composition of a refrigerant changes, characteristics such as COP and pressure also vary, as shown above.

For example, if the percentage of R32 increases in the R-407C refrigerant (that is, when the mixing ratio moves up toward R32 from point (1) position), the refrigerant's COP and pressure characteristic increase.



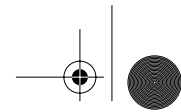

3.2 Refrigerant Oil Characteristics

Main characteristics of ether oil are shown in the following table.

	Synthetic oil	Mineral oil
	Ether oil	
Type (maker)	FVC68D (Idemitsu Kosan)	Suniso 4GS (Nippon Sun Oil)
Applicable refrigerants (Daikin products)★1	R-407C	R22
Density (g/cm ³)	0.94	0.92
Total acid number (mgKOH/g)	0.01	0.01
Saturated moisture level (ppm)	2000	100
Volume insulation resistivity (Ωcm)	3×10 ¹³ or less	5×10 ¹⁴ or less
Hydrolysis (stability range)	No degradation	No degradation
Oxidation degradation (stability range)	0.03% or less	0.03% or less
Moisture absorption	(As shown in graph below)	(As shown in graph below)
Solubility in refrigerant	(As shown in graph below)	(As shown in graph below)

★1 : Applicability may differ in products of other manufacturers.

Moisture Absorption

The graph on the below shows how the moisture absorption (moisture level) changes over time in suniso, ester oil and ether oil.

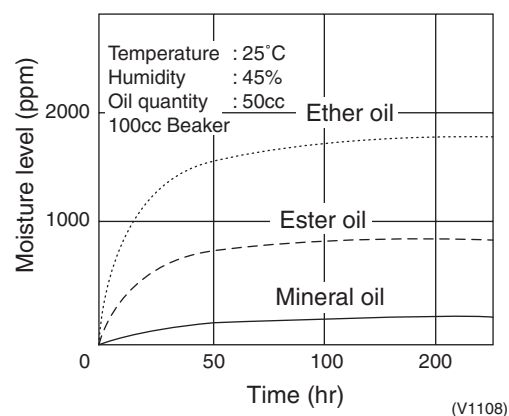

Solubility in Refrigerant

The graph on the below shows the oil solubility of different combination of refrigerant and chiller oil.

→ A combination of suniso and HFC refrigerant results in a separation of refrigerant and oil in almost the entire range. (No solubility)

→ A combination ether oil and HFC refrigerant remains dissolved in a wide range.

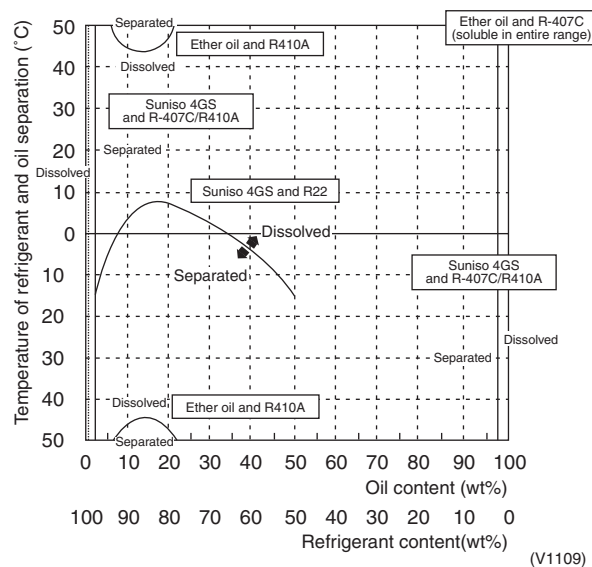

4. Refrigerant Cylinders

4.1 Cylinder Specifications

- The color painted on a cylinder indicates the contained refrigerant type.

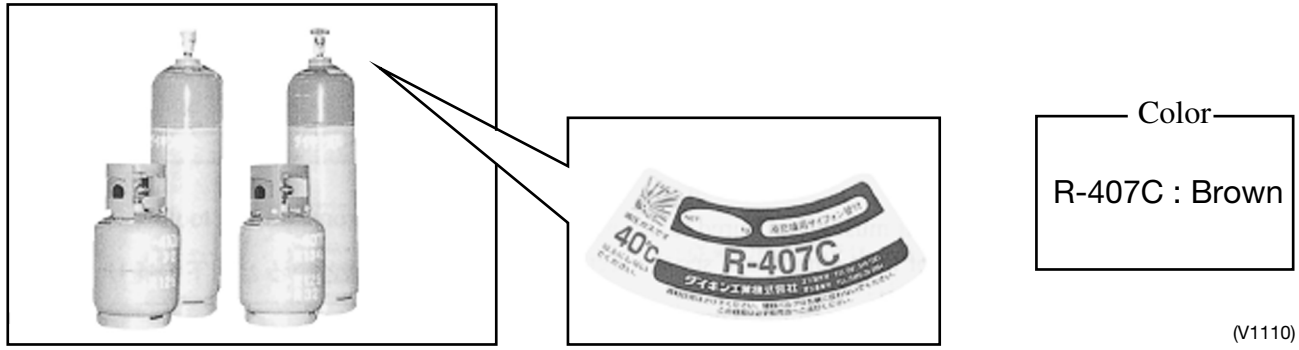

- The cylinder valve is equipped with a siphon tube.

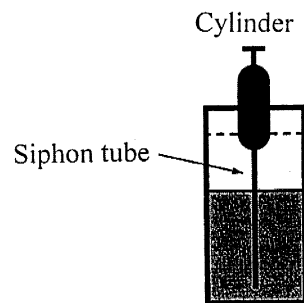

Refrigerant can be charged in liquid state with cylinder in upright position.

Caution: Do not lay cylinder on its side during charging, since it cause refrigerant in gas state to enter the system.

(V1111)

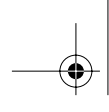

4.2 Handling of Cylinders

1. Legal regulations

R-407C are liquefied gases, and the High-Pressure Gas Safety Law must be observed in handling them. Before using, refer to the High-Pressure Gas Safety Law.

The High-Pressure Gas Safety Law specifies standards and regulations that must be followed to ensure the safe use of high-pressure gases. Be sure to follow the regulations to prevent accidents.

2. Handling of vessels

Since R-407C are high-pressure gases, they are contained in high-pressure vessels.

Although those vessels are durable and strong, careless handling can cause damage that can lead to unexpected accidents. Do not drop cylinders, let them fall, apply impact or roll them on the ground.

3. Storage

Although R-407C are not flammable, they must be stored in a well-ventilated, cool and dark area in the same way as any other high-pressure gases.

It should be noted that high-pressure vessels are equipped with safety devices that releases gas when the ambient temperature reaches a certain level (fusible plug melts) and when the pressure exceeds a certain level (spring-activated safety valve operates).

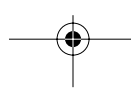
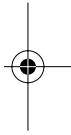
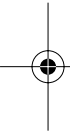

5. Service Tools

R-407C is approximately 10% higher.



These refrigerants use ether oil for refrigerant oil instead of suniso oil. If oil of an incorrect type is mixed in R410A and R-407C, sludge results in the refrigerants and causes equipment problems.

Therefore, gauge manifolds and charge hoses that are used with a previous refrigerant (R22) cannot be used for products that use new refrigerants.

Be sure to use dedicated tools and devices.

5.1 Tool Compatibility

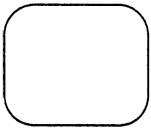
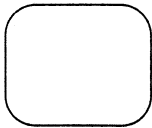
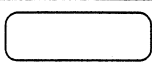
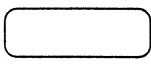
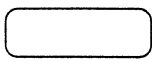
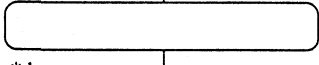
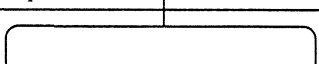
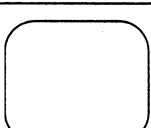
The following chart shows tools that must be procured to use new refrigerants and conventional tools that can be shared. (For details of individual tools, see the section from page177.)

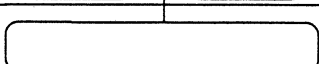
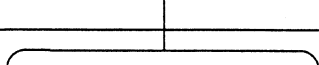
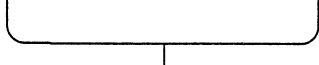
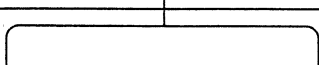
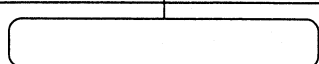
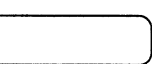
Tool	HFC	HCFC	Remarks
	R407C	R22	
Gauge manifold Charge hose			<ul style="list-style-type: none"> Do not use the same tool for R22 and HFCs. Thread specification differs for R410A and R407C.
Charging cylinder	Measuring instrument currency used for HFCs.		<ul style="list-style-type: none"> Weighting instrument used for HFCs.
Gas detector			<ul style="list-style-type: none"> Same tool can be used for R410A and R407C.
Vacuum pump (pump with reverse flow preventive function)	 *1		*1: To use existing pump for HFCs, vacuum pump adaptor must be installed.
Weighting instrument (for refrigerant charge)			<ul style="list-style-type: none"> Same stool can be used for R22, R407C and R410A.
Charge mouthpiece			<ul style="list-style-type: none"> Seal material is different for R22 and HFCs. Thread specification differs for R410A.
Flaring tool			
Torque wrench			
Pipe cutter			<ul style="list-style-type: none"> Same stool can be used for R22 and R407C .
Pipe expander			<ul style="list-style-type: none"> Same stool can be used for R22 and R407C .
Pipe bender			<ul style="list-style-type: none"> Same stool can be used for R22 and R407C .
Refrigerant recovery device	Currency under development by tool manufacturers		

 : Indicates a range of shared use

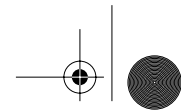

(V1112)



5.2 New Tools Required for HFCs and Reasons of Change

Tool	Reason for new tool
	R-407C
Flaring tool	(Previous tool can be used.)
Pipe assembling oil	Due to chiller oil change (Requires ether oil, ester oil, alkylbenzene oil and their mixtures)
Torque wrench	(Previous tool can be used.)
Gauge manifold Charge hose	For increased pressure and to prevent mixing of impurities. (Different gauge scale, higher pressure resistance)
Charging cylinder	Previous tool cannot be used due to different refrigerant characteristics. (Measuring instrument must be used.)
Vacuum pump	Existing vacuum pump can be used if reverse flow preventive adaptor is installed. Vacuum pumps with reverse flow preventive mechanism are also available.
Gas detector	HFC gas detector must be used.

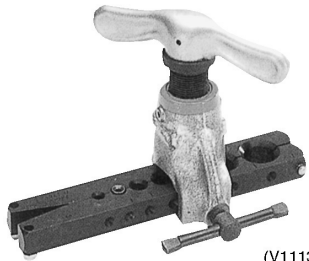

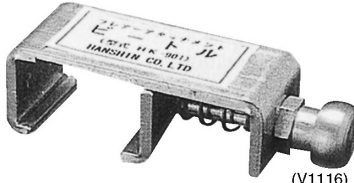
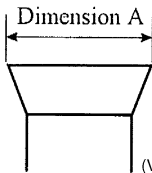
The tools shown in the following section are examples of tools available on the market.
Several companies offer tools for use with HFCs. Contact air conditioner hardware shops for details of tools available in your market.

Tool name	Difference from previous tool	New tool specifications		
		Unit:mm		
1. Flaring tool  (V1113)  (V1115)  (V1116)	■ Larger dimension A  (V1114) Class-1 pipes:R-407C	Nominal size	Class-1 +0 -0.4	Previous
		1/4	9.0	8.0~9.0
		3/8	13.0	12.6~13.0
		1/2	16.2	15.8~16.2
		5/8	19.4	19.0~19.9
		3/4	23.3	22.9~23.3

i Note: Conventional flaring tools can be used for R-407C.

Service Tools

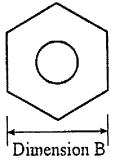
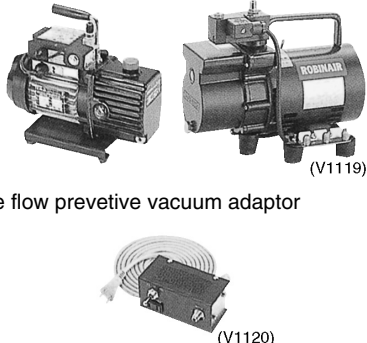
SiE33-003

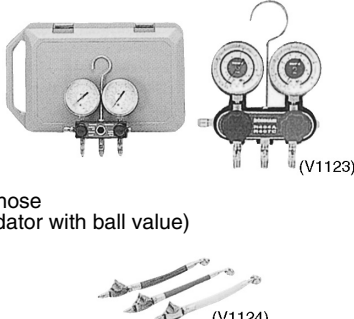
Tool name	Diference from previous tool	New tool specifications												
<p>2. Torque wrench</p>  <p>(V1117)</p>	<p>■ Change of dimension B Size increase only for 1/2" and 5/8" pipes</p>  <p>(V1118)</p> <p>Class-1 pipes : R-407C</p>	<table border="1"> <thead> <tr> <th colspan="2">DimensionB</th> <th>Unit:mm</th> </tr> <tr> <th>Nominal size</th> <th>Class-1</th> <th>Previous</th> </tr> </thead> <tbody> <tr> <td>1/2</td> <td>24</td> <td>24</td> </tr> <tr> <td>3/8</td> <td>27</td> <td>27</td> </tr> </tbody> </table> <p>No change in tightening torque No change in pipes of other sizes</p>	DimensionB		Unit:mm	Nominal size	Class-1	Previous	1/2	24	24	3/8	27	27
DimensionB		Unit:mm												
Nominal size	Class-1	Previous												
1/2	24	24												
3/8	27	27												
<p>3. Vacuum pump with check valve</p>  <p>(V1119)</p> <p>Reverse flow prevetive vacuum adaptor</p> <p>(V1120)</p>	<p>■ Must be equipped with a mechanism to prevent reverse oil flow. ■ Previous vacumm pump can be used by installing adaptor.</p>	<p>EX.) Left side of the left fig. (Tasco Japan)</p> <ul style="list-style-type: none"> ■ Discharge speed 50L/min (50Hz) 60L/min (60Hz) ■ Maximum degree of vacuum 5×10^{-6}Torr ■ Suction port UNF7/16-20 (1/4"flare) UNF1/2-20 (5/16"flare) with adaptor 												
<p>4. Leak tester</p>  <p>(V1121)</p>	<p>■ Previous testers detected chlorine. Since HFCs do not contain chlorine, new testers detect hydrogen.</p>	<ul style="list-style-type: none"> ■ Hydorogen detecting type ■ Applicabe refrigerants R410A, R-407C, R404A, R507AR134a, etc. 												
<p>5. Refrigerant oil (Air Compal)</p>  <p>(V1122)</p>	<p>■ Can be used for HFC and HCFC units.</p>	<ul style="list-style-type: none"> ■ Contains synthetic oil, therefore it can be used for all types of refrigerant piping. ■ Offers high rust resistance and stability over long period of time. 												
<p>6. Gauge manifold for R-407C</p>  <p>(V1123)</p> <p>Charge hose (Hose adator with ball value)</p> <p>(V1124)</p>	<p>■ Oil and refrigerant types are different. (Previous gauge manifold cannot be used.)</p>	<ul style="list-style-type: none"> ■ High pressure gauge -0.1~3.5Mpa (-76cmHg~35kg/cm²) ■ Low pressure gauge -0.1~1.5Mpa (-76cmHg~cm²) ■ 1/4" ■ Available with and without hand-operate valve that prevents refrigerant from escaping from hose. ■ No oil is used in pressure test of gauges.→ Prevention of gauge contamination ■ Temperature graduation indicates the relationship between pressure and temperature in gas saturation condition. 												

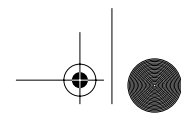

SiE33-003

Service Tools

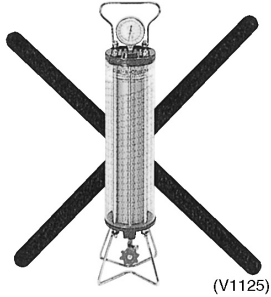
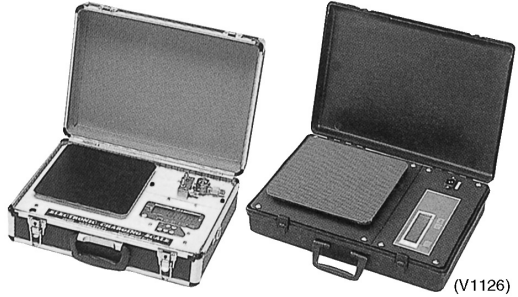
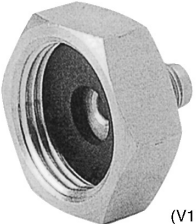
Tool name	Diference from previous tool	New tool specifications
<p>7. Charging cylinder</p>  <p>(V1125)</p>	<ul style="list-style-type: none"> ■ Cannot be used since charging cylinders cause change in mixing ratio in multi-substance refrigerants during charging. 	<ul style="list-style-type: none"> ■ Use weighting instrument listed below for refrigerant charge.
<p>8. Weighing instrument for refrigerant charge</p>  <p>(V1126)</p>	<ul style="list-style-type: none"> ■ Mesurement is based on weight to prevent change of mixing ratio during charging. 	<p>EX.) Left side of left fig. (Tasco Japan)</p> <ul style="list-style-type: none"> ■ High accuracy TA101A (for 10-kg cylinders) : ±2g TA101B (for 20-kg cylinders) : ±5g ■ Equipped with pressure-resistant sight glass (allow checking of liquid-state refrigerant) ■ Standardizeed manifold with separate ports for HFCs and previous refrigerants (allows use of new and previous refrigerants)
<p>9. Charge monthpiece</p>  <p>(V1127)</p>	<ul style="list-style-type: none"> ■ Change of seal material for use with HFCs 	<ul style="list-style-type: none"> ■ Material changed from CR to H-NBR.



New Refrigerant R-407C

179

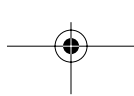

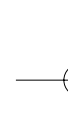

6. Cautions During Service Operations (Changes Required by New Refrigerants)

6.1 The Three Basic Rules for Refrigerant Piping Must Be More Strictly Observed

With new refrigerants, the three basic rules for refrigerant piping must be more strictly observed during piping as well as servicing.

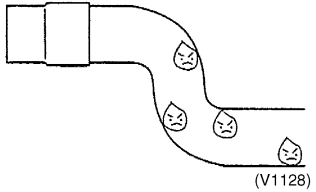
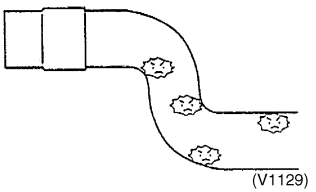
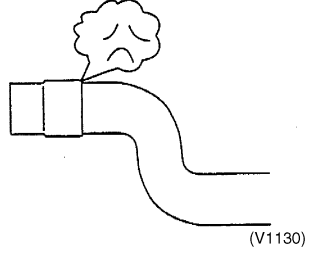
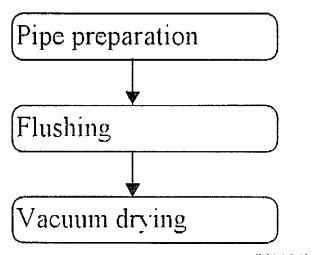
	1. Drying (no moisture)	2. Cleaning (free of contamination)	3. Tightening (air-tightness)
	There shall be no moisture in the pipe.	There shall be no dust in the pipe.	There shall be no refrigerant leak.
Item			
Cause	<ul style="list-style-type: none"> ■ Water entering from outside, such as rain. ■ Moisture due to dew condensation occurring inside the pipe. 	<ul style="list-style-type: none"> ■ Oxidized film generated during brazing. ■ Entering of dust, particles, oil, etc. from outside. 	<ul style="list-style-type: none"> ■ Insufficient brazing. ■ Inadequate flaring or insufficient tightening torque. ■ Inadequate flange connection.
Problem	<ul style="list-style-type: none"> ■ Clogging of expansion valve, capillary tube, etc. ■ Insufficient cooling or heating. ■ Degradation of refrigerating machine oil. ■ Malfunction of compressor. 	<ul style="list-style-type: none"> ■ Clogging of expansion valve, capillary tube, etc. ■ Insufficient cooling or heating. ■ Degradation of refrigerating machine oil. ■ Malfunction of compressor. 	<ul style="list-style-type: none"> ■ Gas shortage. ■ Insufficient cooling or heating. ■ Temperature rising of discharge gas. ■ Degradation of refrigerating machine oil. ■ Malfunction of compressor.
Preventive measure		<ul style="list-style-type: none"> ■ Same as the items on the left. ■ Do not use tools or devices previously used with a different type of refrigerant. 	<ul style="list-style-type: none"> ■ Follow the basic brazing procedure. ■ Follow the basic flaring procedure. ■ Follow the basic flange connection procedure. ■ Conduct an air-tightness test (gas leak check).

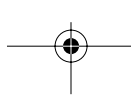
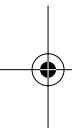

7. Operation Guideline

7.1 Operation Guideline

The following guideline figures in the table indicate refrigerant conditions. These values are obtained in a simulation conducted under the conditions listed under the table.

(Source : DAIREP2.0)

		R22	R-407C	R410A
Discharge pressure (high pressure)	MPa(kgf/cm ²)	1.94 (19.8)	2.11 (21.5)	3.07 (31.3)
Suction pressure (low pressure)	Mpa(kgf/cm ²)	0.58 (5.96)	0.59 (5.97)	0.93 (9.53)
Discharge temperature	°C	74.07	70.67	74.99
Suction temperature	°C	10.00	12.26	10.05

(Conditions)

Condensation temperature : 50°C, evaporation temperature : 5°C, degree of supercool : 5°C, degree of superheat : 5°C

The other simulation conditions for R22, R-407C and R410A are same. Absolute pressure was used for discharge pressure and suction pressure.

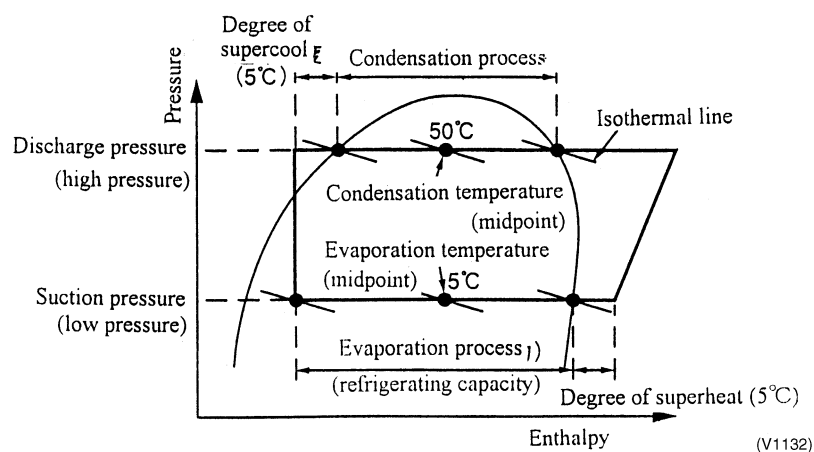

Unlike R22, the new refrigerants, R-407C undergo a temperature change during a phase change (condensation process and evaporation process).

→To diagnose problems using the temperature difference at the inlet and outlet of a heat exchanger, take into consideration the temperature difference caused by the above temperature change. (Temperature drops during condensation process, while it increases during evaporation process.)

Graphs based on above simulation results

R-407C

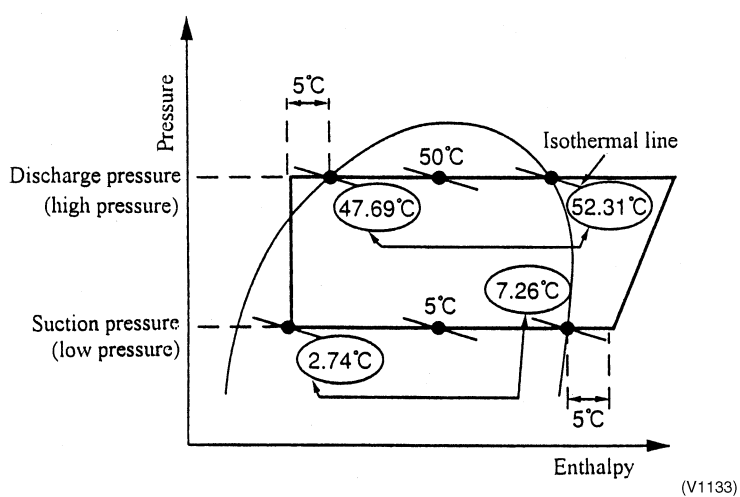

Note: In actual products, conditions may differ slightly, as the figures shown above.

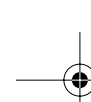

8. Temperature-pressure Conversion Table for New Refrigerants

8.1 Pressure and Temperature

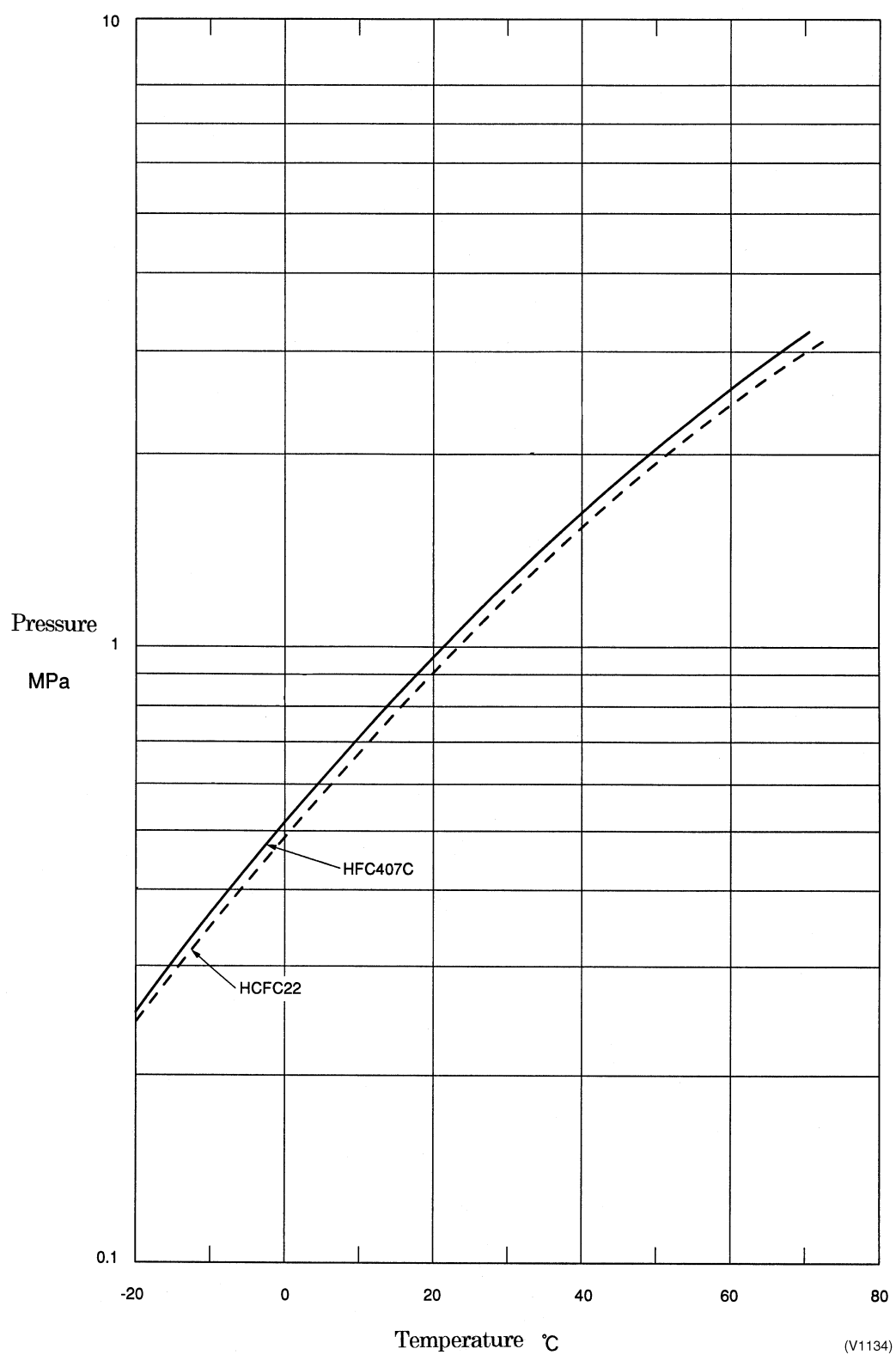

9. Measures to Take in the Case of Gas Leaks

9.1 Gas Shortage

Problems caused by insufficient gas are almost the same as those for R22 air conditioners. They include capacity decrease, compressor overheating and frost accumulation on cooler.

(Guideline for judging gas shortage)

- The following shows the relationship between pressure and temperature for R22 and R-407C. Use the data as the guideline when checking pressure levels.

Refrigerant	Condensation pressure MPa (kgf/cm ²) ★1	Evaporation pressure MPa(kgf/cm ²) ★2
R22	1.84 (18.8)	0.48 (4.92)
R-407C	2.00 (20.5)	0.51 (5.16)

★1 Intermediate pressure between saturation liquid pressure and saturation gas pressure at 50°C temperature (gauge pressure)

★2 Intermediate pressure between saturation liquid pressure and saturation gas pressure at 0°C temperature (gauge pressure)

(Composition change and capacity decrease caused by gas leaks)

- The following composition change occurs when the refrigerant gas leaks, particularly with R-407C, since R-407C is a non-azeotropic mixture.

○ : (Boiling point - 26.6°C)

▲ : (Boiling point - 48.6°C)

□ : (Boiling point - 51.8°C)

Pressure at constant level

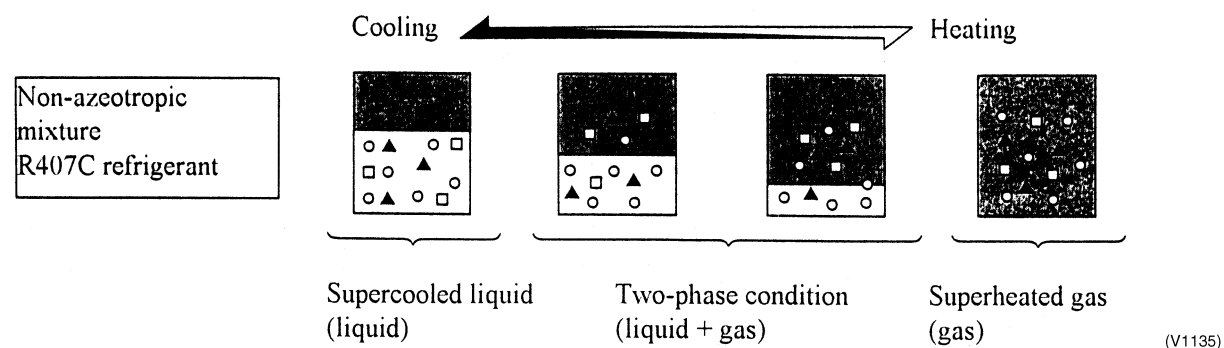

- Due to the above composition change, the percentage of R134a increases, thus causing a capacity drop. The degree of capacity drop that a gas shortage causes is nearly the same in R22 air conditioners and R-407C air conditioners.

9.2 Measure for Gas Shortage

To correct problems caused by a gas shortage, it is necessary to repair leaks and replace all refrigerant. In the case of urgency, additional refrigerant charge is acceptable. However, if the problem is corrected by an additional refrigerant charge, a slight capacity decrease may result due to the refrigerant composition change.

(Capacity change caused by refrigerant leaks)

- If R-407C refrigerant is added in the exact amount as leaked refrigerant, the air conditioner's capacity changes as shown below.

(Example) When 50% of refrigerant leaks, the capacity decreases approximately 5%.

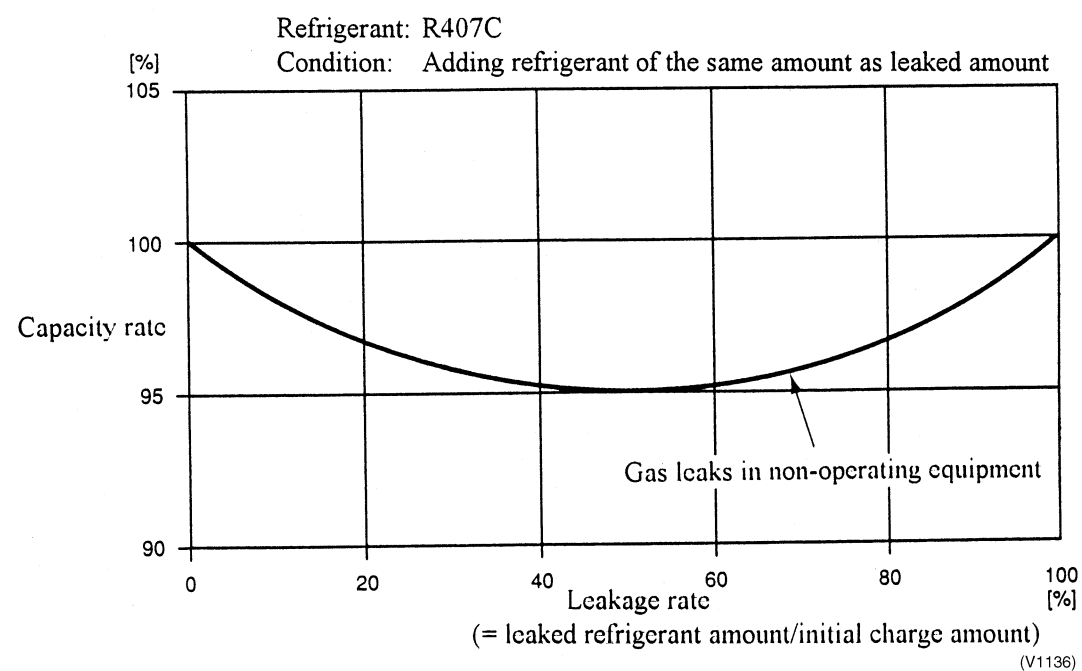

When 50% of the total refrigerant capacity is added and the capacity decreases from 100% (original condition) to 95%, the pressure (under the same temperature condition) and the degree of superheat in the compressor tend to drop very slightly. However, in actual products, the rates of decrease vary depending on the control function of individual models.

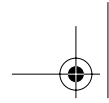

10. Safety Precautions

10.1 Safety Precautions

**HFC refrigerants require special caution since are under high pressure.
(R-407C is approximately 10% higher in pressure than R22)**

Extra caution must be exercised in the following cases.

1. When disconnecting a hose from the service port with refrigerant remaining inside the charge hose
(When a hose is disconnected with a refrigerant inside, the hose may move around violently or refrigerant may shoot out.)
2. When disconnecting a connection pipe with a refrigerant remaining inside the charge hose (Refrigerant may shoot out from the disconnected section.)

Caution regarding ventilation

R-407C is heavier than air and tend to stay near the floor. Gas leaks can, therefore. cause oxygen deficiency in the work area.

Use of a flame in an environment containing an R-407C gas generates a unpleasant, corrosive and toxic gas.

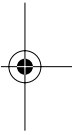
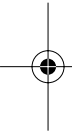

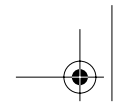

11. Problems Resulting from Negligence of Caution Items

11.1 Problems Resulting from Negligence of Caution Items

Problems resulting from charging a wrong type of refrigerant

1. When R22 is charged into an air conditioner designed for a new refrigerant
2. When an R22 air conditioner is charged with a new refrigerant
3. When a mistake is made between R410A and R-407C in refrigerant charging

Do not make any of the above mistakes 1, 2 and 3. Errors 1 and 2 can damage the compressor.

1. When R22 is charged into an air conditioner designed for a new alternative refrigerant Chlorine in R22 corrodes the chiller oil. Degradation of the chiller oil deteriorates the lubricating performance of the oil.
2. When an R22 air conditioner is charged with a new refrigerant
HFCs are not compatible with mineral oil, therefore degradation of oil return performance results. Furthermore, the refrigerant and oil separate into a two-phase state inside the compressor, and causes a lack of oil supply to the bearing, resulting in inadequate bearing lubrication.
R410A is higher in pressure than R22. Since R22 air conditioners are not designed to withstand the pressure of R410A, if R410A is charged into an R22 air conditioner, an extremely dangerous condition can result.
3. When a mistake is made between R410A and R-407C in refrigerant charging
The refrigerant composition changes. This not only causes a capacity decrease but also results in equipment malfunction and damage in some cases.
R410A is higher in pressure than R-407C. Since R-407C air conditioners are not designed to withstand the pressure of R410A, if R410A is charge into an R-407C air conditioner, an extremely dangerous condition can result.

Problems resulting from using suniso (mineral oil) in air conditioners using new refrigerants (R401C, R410A)

Suniso causes degradation of ether oil, and this causes lubricating deficiency in the compressor and clogging in the capillary tube, thereby leading to equipment damage.

Example

Chiller oil degradation due to mixing of impurities

↓
Insufficient lubrication



Insufficient lubrication

Compressor damage



(V1137)

12. Difference Between Pascal and Conventional Pressure Unit

12.1 Comparison of MPa and kgf/cm²

MPa (gauge pressure) kgf/cm²

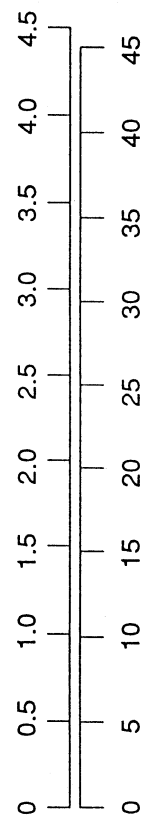

(V1138)

13. Thermodynamic Characteristic Charts (HFC407C)

13.1 Thermodynamic Characteristics of R-407C

Temperature (°C)	Steam pressure (kPa)		Density (kg/m ³)		Specific heat at constant pressure (kJ/kgK)		Specific enthalpy (kJ/kg)		Specific entropy (kJ/kgK)	
	Liquid	Vapor	Liquid	Vapor	Liquid	Vapor	Liquid	Vapor	Liquid	Vapor
	DAIREP ver2.0									
-70	23.54	14.46	1456.2	0.745	1.305	0.671	101.7	370.7	0.690	2.208
-68	26.69	16.59	1450.4	0.848	1.309	0.676	104.3	371.9	0.703	2.021
-66	30.17	18.98	1444.7	0.962	1.312	0.680	106.9	373.2	0.716	2.014
-64	34.03	21.64	1438.8	1.088	1.314	0.685	109.6	374.4	0.728	2.008
-62	38.27	24.61	1433.0	1.227	1.315	0.690	112.2	375.6	0.741	2.001
-60	42.94	27.91	1427.1	1.380	1.316	0.694	114.8	376.9	0.753	1.995
-58	48.05	31.56	1421.2	1.548	1.316	0.699	117.5	378.1	0.766	1.989
-56	53.65	35.59	1415.2	1.733	1.316	0.704	120.1	379.3	0.778	1.983
-54	59.76	40.03	1409.3	1.934	1.316	0.710	122.7	380.5	0.790	1.978
-52	66.42	44.91	1403.3	2.155	1.316	0.715	125.4	381.8	0.802	1.973
-50	73.67	50.27	1397.4	2.395	1.317	0.720	128.0	383.0	0.814	1.967
-48	81.53	56.13	1391.4	2.656	1.318	0.726	130.6	384.2	0.825	1.962
-46	90.05	62.53	1385.4	2.939	1.319	0.732	133.3	385.4	0.837	1.958
-44	99.26	69.52	1379.4	3.246	1.321	0.737	135.9	386.6	0.849	1.953
-43.57	101.32	71.09	1378.1	3.315	1.321	0.739	136.5	386.8	0.851	1.952
-42	109.21	77.11	1373.3	3.579	1.323	0.743	138.6	387.8	0.860	1.948
-40	119.93	85.36	1367.2	3.937	1.325	0.749	141.2	389.0	0.871	1.944
-38	131.47	94.30	1361.1	4.324	1.328	0.756	143.9	390.1	0.883	1.940
-36	143.86	103.97	1355.0	4.741	1.331	0.762	146.5	391.3	0.894	1.936
-34	157.15	114.41	1348.9	5.189	1.335	0.769	149.2	392.5	0.905	1.932
-32	171.39	125.68	1342.7	5.670	1.339	0.775	151.9	393.6	0.916	1.928
-30	186.63	137.80	1336.4	6.186	1.343	0.782	154.6	394.8	0.927	1.924
-28	202.90	150.84	1330.1	6.739	1.348	0.789	157.3	395.9	0.938	1.921
-26	220.25	164.83	1323.8	7.331	1.353	0.797	160.0	397.0	0.949	1.917
-24	238.73	179.82	1317.4	7.963	1.359	0.804	162.7	398.1	0.960	1.914
-22	258.40	195.87	1311.0	8.638	1.364	0.812	165.4	399.2	0.971	1.910
-20	279.30	213.02	1304.5	9.357	1.370	0.820	168.2	400.3	0.982	1.907
-18	301.48	231.33	1297.9	10.12	1.377	0.828	170.9	401.4	0.993	1.904
-16	325.00	250.85	1291.3	10.94	1.383	0.836	173.7	402.5	1.003	1.901
-14	349.90	271.63	1284.7	11.81	1.390	0.845	176.5	403.5	1.014	1.898
-12	376.25	293.73	1277.9	12.73	1.396	0.854	179.3	404.6	1.025	1.895
-10	404.08	317.21	1271.1	13.71	1.403	0.863	182.1	405.6	1.035	1.892
-8	433.47	342.11	1264.2	14.75	1.411	0.872	184.9	406.6	1.046	1.889
-6	464.46	368.51	1257.2	15.85	1.418	0.882	187.7	407.6	1.056	1.887
-4	497.11	396.47	1250.1	17.02	1.425	0.892	190.6	408.6	1.067	1.884
-2	531.47	426.03	1243.0	18.26	1.433	0.903	193.4	409.5	1.077	1.881
0	567.61	457.27	1235.8	19.57	1.441	0.913	196.3	410.5	1.088	1.879
2	605.59	490.26	1228.4	20.95	1.449	0.924	199.2	411.4	1.098	1.876
4	645.45	525.04	1221.0	22.42	1.457	0.936	202.1	412.3	1.109	1.874
6	687.27	561.70	1213.5	23.97	1.465	0.948	205.0	413.2	1.119	1.871
8	731.09	600.30	1205.9	25.60	1.473	0.960	208.0	414.1	1.130	1.869
10	776.99	640.90	1198.2	27.33	1.482	0.973	210.9	414.9	1.140	1.866
12	825.02	683.58	1190.3	29.16	1.490	0.987	213.9	415.8	1.150	1.864
14	875.24	728.41	1182.4	31.08	1.499	1.001	216.9	416.6	1.161	1.861
16	927.72	775.46	1174.3	33.12	1.508	1.015	219.9	417.4	1.171	1.859
18	982.52	824.81	1166.2	35.26	1.518	1.030	222.9	418.1	1.181	1.857
20	1039.7	876.52	1157.9	37.53	1.527	1.046	226.0	418.8	1.191	1.854
22	1099.3	930.69	1149.4	39.92	1.538	1.063	229.0	419.5	1.202	1.852
24	1161.5	987.38	1140.9	42.44	1.548	1.081	232.1	420.2	1.212	1.850
26	1226.2	1046.7	1132.2	45.10	1.559	1.099	235.2	420.9	1.222	1.847
28	1293.5	1108.7	1123.3	47.91	1.571	1.118	238.3	421.5	1.232	1.845
30	1363.6	1173.4	1114.3	50.87	1.583	1.139	241.4	422.1	1.242	1.842
32	1436.4	1241.0	1105.1	54.00	1.596	1.161	244.6	422.6	1.252	1.840
34	1512.1	1311.6	1095.8	57.31	1.610	1.184	247.8	423.1	1.263	1.838
36	1590.7	1385.2	1086.3	60.80	1.625	1.208	251.0	423.6	1.273	1.835
38	1672.2	1461.9	1076.6	64.49	1.641	1.234	254.2	424.0	1.283	1.833
40	1756.7	1541.9	1066.6	68.40	1.658	1.263	257.5	424.4	1.293	1.830
42	1844.4	1625.1	1056.5	72.54	1.677	1.293	260.7	424.8	1.303	1.827
44	1935.2	1711.8	1046.1	76.93	1.698	1.325	264.1	425.1	1.313	1.825
46	2029.3	1802.0	1035.5	81.58	1.720	1.361	267.4	425.3	1.324	1.822
48	2126.6	1895.8	1024.6	86.52	1.745	1.399	270.8	425.5	1.334	1.819
50	2227.3	1993.4	1013.5	91.78	1.773	1.442	274.2	425.6	1.344	1.816
52	2331.4	2094.8	1001.9	97.38	1.804	1.488	277.7	425.7	1.355	1.813
54	2439.0	2200.2	990.1	103.4	1.838	1.540	281.2	425.7	1.365	1.809
56	2550.2	2309.7	977.8	109.8	1.878	1.598	284.7	425.6	1.376	1.806
58	2664.9	2423.3	965.1	116.6	1.922	1.664	288.3	425.4	1.386	1.802
60	2783.2	2541.4	951.9	124.0	1.973	1.739	292.0	425.1	1.397	1.799
62	2905.3	2664.0	938.2	132.0	2.033	1.826	295.7	424.7	1.408	1.794
64	3031.0	2791.2	923.8	140.7	2.103	1.928	299.6	424.2	1.419	1.790
66	3160.5	2923.3	908.6	150.1	2.186	2.049	303.5	423.5	1.430	1.785
68	3293.8	3060.4	892.6	160.5	2.288	2.197	307.5	422.6	1.441	1.780
70	3430.8	3202.7	875.5	172.0	2.413	2.382	311.7	421.5	1.453	1.775

(V1139)

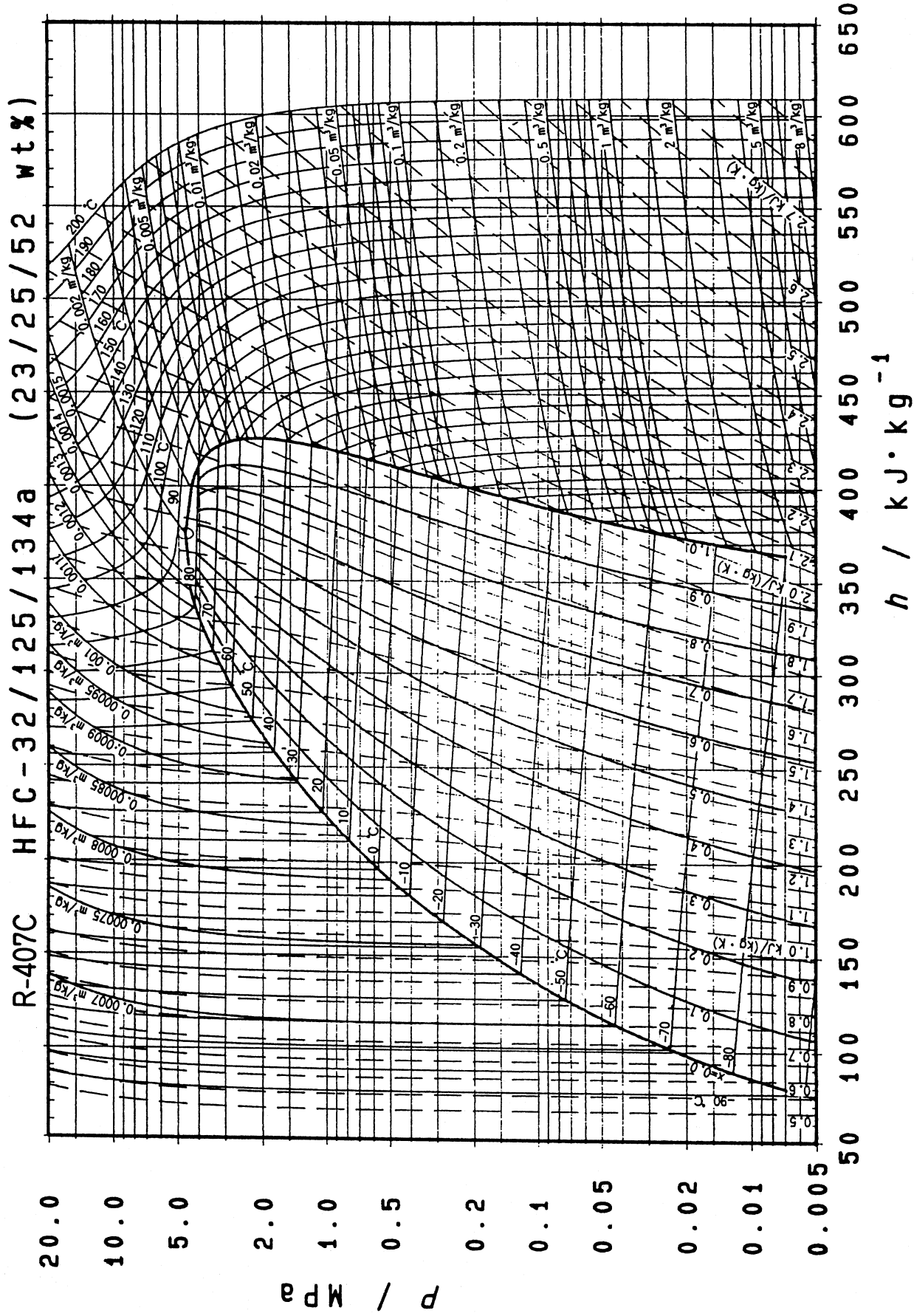
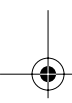
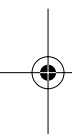
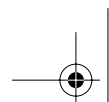

Fig. 7 Pressure-enthalpy curves of HFC-32/125/134a (23/25/52 wt%)

(V1140)





Index

Symbols

"88" cannot be cleared
from the central remote control 122

A

Additional Charge of Refrigerant34, 97
Additional Refrigerant Charge145
Additional Refrigerant Charge Operation77
Air Tight Test27
Allowable Piping Length94

B

Brazing21

C

Centralized Control Group No. Setting84
Changes Required by New Refrigerant170
Checks before Initial Start-Up158
Code No.82
Combination126
Connecting the Refrigerant Piping138
Control Modes86
Control Wiring47
Cool / Heat Mode Selection68
Cool/Heat Operation156
Cracks develop in field pipes
due to thermal expansion and contraction120
Cylinder Specifications174

D

Demand Control74
Drain Pipe Gradient and Support36
Drain pipe trap shape defective117
Drain Pipe Work Indoor units36
Drain Piping for Each Model
FXYCP-2-way blow ceiling mounted cassette .39
FXYFP-4-way blow ceiling mounted cassette .40
FXYKP-ceiling mounted corner cassette42
FXYSP-Concealed ceiling unit45
Drain Trap36

E

Electrical Specifications131
Electrical Work47
Excessive noise due to incorrect angling of
REFNET joints119

F

Field Line Connection153
Field Setting83
Field Wiring147
Flange Connection25
Flare Connection22
Flaring Procedure23

G

Gas Leaks 183
Gas Shortage 183
Grouped Drain Piping 37

H

Hand Over to Customer 91
Handling of Cylinders 175

I

Indoor Field Setting 79
Infrared Remote Control — Indoor Unit 81
Installation 12
Installation of Indoor Unit 14
Installation of Outdoor Unit 51
Internal Wiring 148

L

Leak Test 143
Low Noise Operation 73

M

Main Components 132
Measure for Gas Shortage 184
Mismatch between cables connecting indoor and
outdoor units and corresponding piping 116
Misswiring Check Operation 162
Mode Change 61
Monitor Mode 66

N

New Tools Required
for HFCs and Reasons of Change 177

O

Operating Noise of Indoor Units 92
Operation Guideline 181
Operation Mode 86
Operation When Power is Turned On 58
Optional Accessories 129
Optional Parts Cool/Heat Selector 150

P

PC Board Ass'y
Outdoor Unit 59
Picking Power Line and Transmission Line 157
Pipe Insulation 144
PIPE SIZE REDUCER 103
Piping Diameter for Grouped Drain Pipes 38
Piping Kits for Side and Bottom Piping 104
Piping System Diagrams
Indoor Unit 110
Outdoor Unit 111
Power Circuit and Cable Requirements 151
Power Supply 48

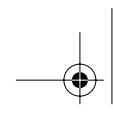

Power Supply Connection	159	Setting Mode 2	64
Pressure and Temperature	182	Setting Modes	61
Pressure down despite absence of leaks during air tight test	118	Short Circuits	53
Problems Resulting from Negligence of Caution Items	186	Signal interference due to use of multiple core cable	115
Pushbutton Switches	61	Sleeve and Insert Work	13
R		Snow Accumulation	54
REFNET HEADER	101	Standard Operation Limit	127
REFNET header	105, 119	Standard Supplied Accessories	128
REFNET JOINT	100	Step by Step Installation Procedure	12
REFNET Joint	140	Stop Valve	159
REFNET joint	105	Stop Valves	160
REFNET joints	119	T	
Refrigerant Characteristics	171	Technical Specifications	130
Refrigerant Cylinders	174	Test Operation	56
Refrigerant Leaks	88, 163	Test Run	159
Refrigerant Oil Characteristics	173	The centralized control group number cannot be set	122
Refrigerant Pipe Size	95	Thermal Insulation Work	26
Refrigerant Pipe Work	15	Tool Compatibility	176
Refrigerant Piping	136	Tools Required	168
Refrigerant Recovery Mode	78	Transmission wiring between the cool/heat selector and the outdoor unit is too close to a high voltage wire	121
S		V	
Safety Precautions	185	Vacuum Drying	29, 143
Selection of Location	133	VRV Inspection Sheet	106
Selection of Piping Material	137	W	
Sequential Start	75, 156	Wired Remote Control – Heat Recovery Ventilation <BRC301B61>	80
Service Mode	83	Wired Remote Control <BRC1A51>	79
Service Operations	180	Wiring Check Operation	76
Service Space	53	Wiring Diagram	113
Service Tools	176		
Setting Contents	82		
Setting Items	64		
Setting Mode 1	63		

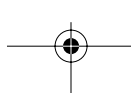

Drawings & Flow Charts

Symbols

"88" cannot be cleared
from the central remote control 122

A

Additional Charge of Refrigerant
Operational steps 34
Refrigerant Charging Instructions 34
Siphon tube 34
Air Tight Test
Checking for Leaks 28
Compensating adjustment value 27
Operational steps 27
Air Tight Test and Vacuum Drying
When conducting an airtightness test 143
When vacuum drying 143
Allowable Piping Length 94

B

Brazing 21

C

Calculating Operating Noise 93
Calibration method 31
Caution for Refrigerant Leaks 88
Centralized Control Group No. Setting
BRC1A51-52 84
BRC7A Type 84
BRC7C Type 85
Group No. Setting Example 85
Change of Composition and Characteristic
in Refrigerant 172
Check points 9
Choice of Materials for Refrigerant Piping 19
Coat the flange sheet surface
with refrigeration oil 25
Coat the inner and outer surface of the flare
with refrigerator oil 22
Combination example 5
Comparison of MPa and kgf/cm² 187
Connect the reducers to the branch piping kit,
KHRP26K75T 103
Connecting the Refrigerant Piping
Bottom Connection 139
Front Connection 138
Piping Between Main Unit (RXYP-)
and Sub Unit (RXEP-) 140
Piping Installation 138
REFNET Joint 140
Refrigerant Pipe Flushing 141
Contents of Control Modes
How to Select Operation Mode 86
Contract Drawing 9
Control circuit diagram 11

Cool / Heat Mode Selection

Setting Method 72
Setting of Cool / Heat by Individual Outdoor Unit
System by Cool/Heat Selector 69
Setting of Cool / Heat by Individual Outdoor Unit
System by Indoor Unit Remote
Control 68
Setting of Cool / Heat by Outdoor Unit System
Group in Accordance with Group Master
Outdoor Unit by Indoor Unit
Remote Control 70
Supplement 71
Correlation of nozzle tip
and size of refrigeration piping 20
Covering of Refrigerant Pipes
Particular care 17
Pinching method 17
Taping method 17
Cracks develop in field pipes
due to thermal expansion and contraction ... 120
Cylinder Specifications 174

D

Dealing with situations where the result exceeds
the dangerous concentration level 90
Degree of vacuum 30
Demand Control System Example 74
Drain pipe trap shape defective 117
Drain Pipe Work (Indoor)
Drain Pipe Gradient and Support 36
Drain Trap 36
Grouped Drain Piping 37
Operational steps 36
Use of an Auxiliary Drain Hose (Flexible) 37
Duct Work (Indoor)
Operational steps 50
Taking Account of Noise and Vibration 50

E

Electrical Work
a PCB for remote control, multiple core cable
must not be used 47
Choosing a circuit breaker 48
Earthing 49
When cable more than 1.25 mm² is used 47
Example of Connection 165
Example of Performing Cool/Heat Setting of Two
or More Outdoor Units in Block
with Cool/Heat Selector 155
Example of Performing Cool/Heat
with Cool/Heat Selector 155
Example of refrigerant branch using REFNET header
for RSXYP28 99
Example of refrigerant branch using REFNET joint
and REFNET header for RSXYP28 99

Example of refrigerant branch using REFNET joint for RSXYP28	99	Heat Pump System Example	97
Excessive noise due to incorrect angling of REFNET joints	119	How these installation problems affect an equipment	7
F		How to fill a tank with a siphon attached	145
Field Line Connection	153	How to Operate Stop Valves	160
Field Line Connection between Main Unit (RXYP-) and Sub Unit (RXEP-)	154	I	
Flare Connection	22	Infrared Remote Control — Indoor Unit	
Flaring Procedure	23	BRC7A type	81
FXYCP-2-way blow ceiling mounted cassette		BRC7C type	81
If converging multiple drain pipes	39	Inspecting and Handling the Unit	134
Install the drain raising pipes at a right angle to the indoor unit	39	Installation of Indoor Unit	
Insulate the drain hose inside the building	39	Example: Ceiling mounted cassette type (FXYCP63K)	14
To keep the drain hose from sagging	39	Operational steps	14
WHEN ELECTRIC WIRING WORK IS NOT FINISHED	40	Positioning	14
FXYFP-4-way blow ceiling mounted cassette		Installation of Outdoor Unit	
If converging multiple drain pipes	41	An inverter air conditioner may cause electronic noise generated from AM broadcasting	55
Install the drain raising pipes at a right angle to the indoor	41	Bolt pitch	51
Insulate the drain hose inside the building	41	Foundation of Units	51
The incline of attached drain hose	41	Operational steps	51
To keep the drain hose from sagging	41	Prevention of Short Circuits	53
WHEN ELECTRIC WIRING WORK IS NOT FINISHED	42	Remove the yellow shipping stays from the compressor support	53
FXYKP-ceiling mounted corner cassette		Selection of Location	55
Adjust the drain raising height by turning the drain raising pipe	43	Service Space	53
If construction work for interconnecting piping is complete	44	Unpacking and Placing the Unit	52
if laying central drain piping	43	L	
Insulate the drain hose inside the building	43	Low Noise Control System Example	73
Keep piping as short as possible and slope it downwards	42	M	
Secure a downward gradient of 1/100 or more for the drain pipe	43	Maximum Concentration Level	163
WHEN ELECTRIC WIRING WORK IS NOT FINISHED	44	Measure for Gas Shortage	184
FXYSP-Concealed ceiling unit		Mismatch between cables connecting indoor and outdoor units and corresponding piping	116
After piping, check to make sure draining flows smoothly	46	Misswiring Check Operation	162
HOW TO INSTALL PIPING	45	Moisture Absorption	173
If the drain hose cannot be sufficiently set on a slope	45	N	
If unifying multiple drain pipes	45	New Tools Required for HFCs and Reasons of Change	177
Keep piping as short as possible and slope it downwards	45	O	
WHEN ELECTRIC WIRING WORK IS NOT FINISHED	46	Operation Guideline	181
G		Other ways of filling the tank	145
Gas Shortage	183	Outdoor Unit PC Board Ass'y	
H		Function of setting	
Hand Over to Customer		between cooling and heating	60
Important Points	91	Function setting mode switch and LED	60
Make the service contact address clear	91	Outdoor Unit	59
Operational Steps	91	Outdoor unit Capacity setting switch	60
		Service monitor LED	60
		Transmission terminal	60
		Outline of New Series Products	
		function-unit-less structure	3
		Individual control of up to 20 indoor units with one 20HP class outdoor unit	4
		Long refrigerant piping	4

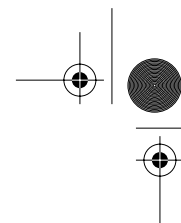
**SiE33-003**

Reduction of installation area	4
System outline	3
P	
Picking Power Line and Transmission Line	157
Pipe size reducer (1)	103
Pipe size reducer (2)	103
Pipe size reducer (3)	103
Piping kit for bottom piping KHF30A30U	104
Piping kit for side piping KHF30A30L	104
Piping System Diagrams	
Indoor Unit	110
RSXYP16-18-20KJY1	111
RSXYP24-26-28-30KJY1	112
Points relating to design of snow hood	54
Positioning of indoor unit	6
Positioning of outdoor unit	6
Pressure and Temperature	182
Pressure down despite absence of leaks	
during air tight test	118
Problems Resulting	
from Negligence of Caution Items	186
Procedure for Checking Maximum	
Concentration	89, 164
R	
REFNET HEADER	
KHRP26K11H	101
KHRP26K17H	101
KHRP26K18H	102
KHRP26K37H	102
KHRP26K40H	102
REFNET header	105
REFNET JOINT	
KHRP26K11T	100
KHRP26K17T	100
KHRP26K18T	100
KHRP26K37T	100
KHRP26K40T	101
KHRP26K75T	101
REFNET joint	105
Refrigerant Characteristics	171
Refrigerant Pipe Flushing	
Fit blanking plugs	18
Flushing	18
Open the main valve on the nitrogen cylinder	
and set the pressure regulator to	
0.5MPa	18
Set pressure regulator on nitrogen cylinder	18
Refrigerant Pipe Work	
Air tight	15
Clean	15
Dry	15
Operational steps	15
The 3 Principles of Refrigerant Piping	15
Remove the yellow shipping stays	
from the compressor support	135
S	
Selection of Location	133
Selection of Refrigerant Pipe Size	95
Sequential Start	75, 156
Setting Modes	
Functions of Pushbutton Switches	61
Mode Change	61
Mode Changing Procedure	62
Monitor Mode	66
Setting Mode 1	63
Setting Mode 2	64
Setting the Cool/Heat Operation	156
Signal interference	
due to use of multiple core cable	115
Sleeve and Insert Work	
Operational steps	13
Steel insert	13
Through holes in a reinforced concrete	
beam	13
Solubility in Refrigerant	173
Sound pressure rise due to room reverberation	92
Special vacuum drying	33
Standard Operation Limit	127
Standard Supplied Accessories	128
standard work practice for all brazing work	16
Step by Step Installation Procedure	12
Striking a Balance between System Installation	
and General Construction Work	8
System Example	153
T	
Test Operation	
Check Operation	57
Check the Following	
Before Turning Power On	56
Turn Power On	56
The analysis of major installation problems	
experienced during the year of 1988	7
The centralized control group number	
cannot be set	122
The Three Basic Rules for Refrigerant Piping	
Must Be More Strictly Observed	180
The use of "hard solder" is essential	20
Thermal Insulation Work (Refrigerant Piping)	
Essential Points of Thermal Insulation	26
Operational steps	26
Thermodynamic Characteristics of R-407C	188
Tighten the bolts in opposite corners first to ensure	
that the connection is true	25
Tool Compatibility	176
Transmission Wiring and Cool/Heat Selection	155
Transmission wiring between the cool/heat selector	
and the outdoor unit is too close to	
a high voltage wire	121
U	
Unpacking and Placing the Unit	135
V	
Vacuum Drying	29
Vacuum Drying Procedure	32
VRV Inspection Sheet	106

Drawings & Flow Charts

v

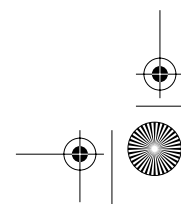
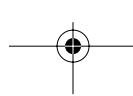

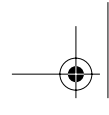

W

When installing the switch box lid160

When you keep on tightening the flare nut
with a spanner161

Wired Remote Control –
Heat Recovery Ventilation <BRC301B61>80

Wired Remote Control <BRC1A51> 79

Wiring Check Operation 76

Wiring Diagram

RSXYP16-18-20KJY1 113

RSXYP24-26-28-30KJY1 114

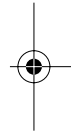

Большая библиотека технической документации

<https://splitsystema48.ru/instrukcii-po-ekspluatácii-kondicionerov.html>

каталоги, инструкции, сервисные мануалы, схемы.